



IGAR-1062+-3G

**Industrial IEEE 802.11 a/b/g/n 3G Cellular Router
with 2x10/100/1000Base-T(X)**

Features

- High Speed Air Connectivity: WLAN interface support up to 300Mbps link speed
- Provide 2 port 10/100/1000Base-T(X) port and 1 sim card slot
- 3.5G HSDPA Modem dial up included
- Provide HNAT enhance LAN to WAN routing performance
- Highly Security Capability: WEP/WPA/WPA-PSK(TKIP,AES)/WPA2/WPA2-PSK(TKIP,AES)/802.1X Authentication supported
- Secured Management by HTTPS
- Various kind of WAN Connection Type supported: Dynamic/Static IP, PPPoE, Modem/Dial Up
- Support client operating mode
- IP table to prevent access from unauthorized IP address
- Support VPN for secured network connection (Open VPN , PPTP, IPSEC, VPN)
- Support NAT Setting (Virtual Server , Port Trigger , DMZ , UPnP)
- 3G Modem signal information display (un-connecting status)
- Wireless connecting status monitoring
- Versatile modes & event alarm by e-mail
- 1KV isolation for PoE P.D. port
- Event Warning by Syslog, Email, SNMP Trap, Relay and Beeper
- Rigid IP-30 housing design
- DIN-Rail and Wall-mount enabled



Introduction

IGAR-1062+-3G is a reliable IEEE 802.11 a/b/g/n WLAN VPN router with 2 ports 10/100/1000Base-T(X) router where ETH1 for LAN and ETH2 for WAN. It supports 802.1X and MAC filter for security control. It could be configured to operate in 3 modes of routing function: Dynamic/Static IP route, PPPoE authentication, and Modem dial up. In the mode of Modem dial up, it support GPRS/3G/3.5G modem by internal 3G module. Users can set up WLAN environment to fulfill demands of various applications rapidly by dialing up internal cellular module. In addition, IGAR-1062+-3G also provides P.D. feature on ETH2 which is fully compliant with IEEE802.3af PoE P.D. specification. This feature extends the layout up to 100 meters. Therefore, IGAR-1062+-3G is one of the best solution for applications of wireless communication.

Application

In IGAR-1062+-3G, there are 3 modes of routing functions supported: Dynamic/Static IP route, PPPoE dial up, and Modem dial up. IGAR-1062+-3G also support NAT, VPN and Back up functions. You can build up the wireless network and connect to the Internet easily.

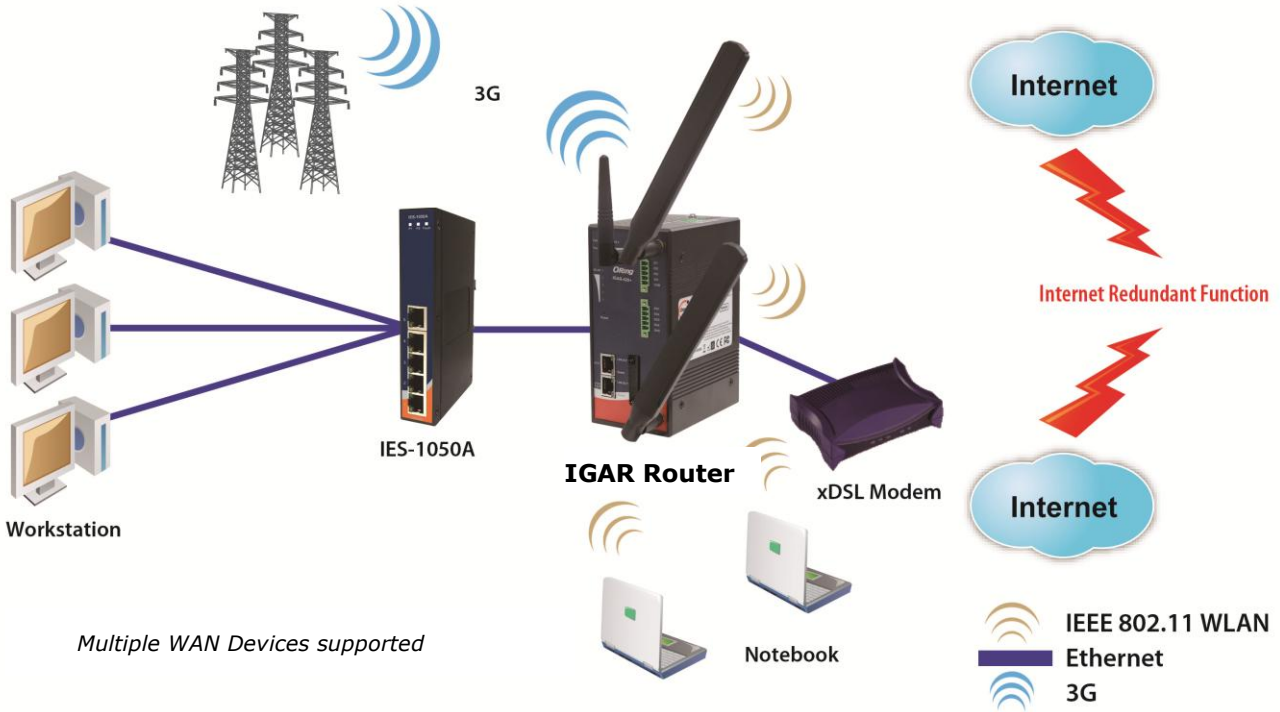

Dimension

Dimension (Unit =mm)

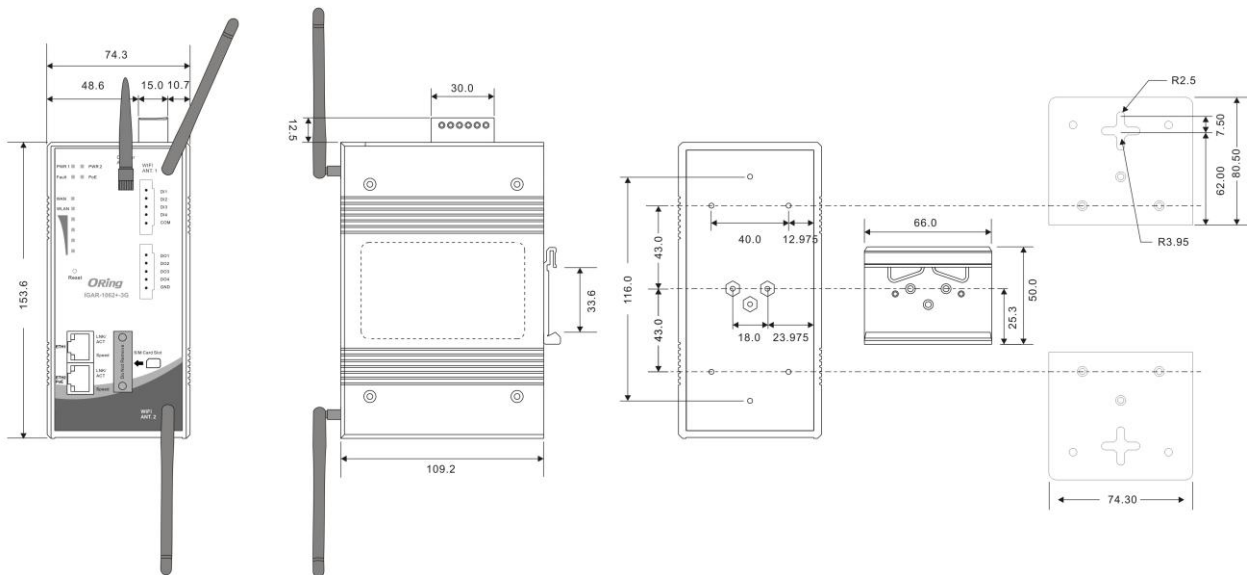

DI/DO Definition

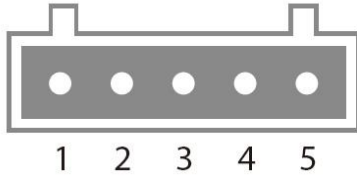

Digital Input Pin Definition

PIN	1	2	3	4	5
Function	DI1	DI2	DI3	DI4	COM

Digital Output Pin Definition

PIN	1	2	3	4	5
Function	DO1	DO2	DO3	DO4	GND

Specifications

ORing AP Router Model	IGAR-1062+3G
Physical Ports	
10/100/1000 Base-T(X) Ports in RJ45 Auto MDI/MDIX	2
PoE P.D. port	Present at ETH2 Fully compliant with IEEE 802.3af Power Device specification Over load & short circuit protection Isolation Voltage: 1000 VDC min. Isolation Resistance : 10 ⁸ ohms min
5-Pin Terminal Block	2(DI x 4 and DO x 4)
Sim Card Slot	1
Cellular Interface	
Antenna Connector	1 x Reverse SMA Female
Cellular Standard	GSM / GPRS/ EGPRS/ EDGE / WCDMA / HSDPA / HSUPA
Band Option	Dual-band : HSUPA 1900/2100 MHz Quad-band : GSM/GPRS/EDGE 850/900/1800/1900 MHz WCDMA/HSDPA 850/900/1900/2100 MHz
WLAN interface	
Antenna Connector	2 x Reverse SMA Female

Modulation	IEEE802.11b: CCK/DQPSK/DBPSK IEEE802.11a/g: OFDM IEEE802.11n: BPSK, QPSK, 16-QAM, 64-QAM
Frequency Band	America / FCC: 2.412~2.462 GHz (11 channels) 5.180~5.240 GHz & 5.745~5.825 GHz (9 channels) Europe CE / ETSI: 2.412~2.472 GHz (13 channels) 5.180~5.240 GHz (4 channels)
Transmission Rate	802.11b: 1/2/5.5/11 Mbps 802.11a/g: 6/9/12/18/24/36/48/54 Mbps 802.11n(40MHz): UP to 300 Mbps
Transmit Power	802.11a: 12dBm ± 1.5dBm@54Mbps 802.11b: 17dBm ± 1.5dBm@11Mbps 802.11g: 16dBm ± 1.5dBm@54Mbps 802.11gn HT20: 15dBm ± 1.5dBm @MCS7 802.11gn HT40: 14dBm ± 1.5dBm @MCS7 802.11an HT20: 12dBm ± 1.5dBm @MCS7 802.11an HT40: 11dBm ± 1.5dBm @MCS7
Receiver Sensitivity	802.11a : -76dBm ± 2dBm@54Mbps 802.11b : -85dBm ± 2dBm@11Mbps 802.11g : -76dBm ± 2dBm@54Mbps 802.11gn HT20:-75dBm ± 2dBm@MCS7 802.11gn HT40:-72dBm ± 2dBm@MCS7 802.11an HT20:-74dBm ± 2dBm@MCS7 802.11an HT40:-71dBm ± 2dBm@MCS7
Encryption Security	WEP: (64-bit ,128-bit key supported) WPA/WPA2 :802.11i(WEP and AES encryption) WPA-PSK (256-bit key pre-shared key supported) 802.1X Authentication supported TKIP encryption
Wireless Security	SSID broadcast disable
LED indicators	
Power indicator	3 x LEDs, PWR1(2)(PoE) / Ready: Red On : Power is on and booting up Green On : Power is on and functioning Normal
10/100/1000T RJ45 port indicator	2 x LEDs, LNK/ACT:Green for port Act. Speed: Green for port Link at 1000Mbps Amber for port Link at 100Mbps. Off for port Link at 10Mbps
WLAN LEDs:	Green Solid On: RF on, Blink: data transmitting Green for WLAN Strength: 1<25%, 2<50%, 3<75%, 4<100%
WAN LEDs:	Green On : Power is on and functioning Normal
Fault	1 x LED, Red for Ethernet link down or power down indicator
Fault contact	
Relay	Relay output to carry capacity of 1A at 24VDC
Power	
Redundant Input power	Dual DC inputs. 12-48VDC on 6-pin terminal block
Power consumption	9 Watts
Overload current protection	Present
Reverse polarity protection	Present
Physical Characteristic	
Enclosure	IP-30
Dimension (W x D x H)	74.3(W) x 109.2(D) x 153.6(H) mm (2.93 x 4.3 x 6.05 inch.)
Weight (g)	1055g
Environmental	
Storage Temperature	-40 to 85oC (-40 to 185°F)
Operating Temperature	-25 to 70°C (-13 to 158°F)
Operating Humidity	5% to 95% Non-condensing

Regulatory approvals	
EMI	FCC Part 15, CISPR (EN55022) class A
EMS	EN61000-4-2 (ESD), EN61000-4-3 (RS), EN61000-4-4 (EFT), EN61000-4-5 (Surge), EN61000-4-6 (CS), EN61000-4-8, EN61000-4-11
Shock	IEC60068-2-27
Free Fall	IEC60068-2-32
Vibration	IEC60068-2-6
Safety	EN60950-1
Warranty	5 years

Ordering Information

IGAR-ABCDE FF

Code Definition	Cellular Module Number	2 nd Wireless Mode	1 st Wireless Mode	Giga Ethernet Port Number	PoE Identification	Cellular Generation
Option	1: One SIM 2: Dual SIM	1: 802.11 b/g 2: 802.11 a 3: 802.11 a/b/g 4: 802.11 b/g/n 5: 802.11 a/n 6: 802.11 a/b/g/n	1: 802.11 b/g 2: 802.11 a 3: 802.11 a/b/g 4: 802.11 b/g/n 5: 802.11 a/n 6: 802.11 a/b/g/n	2: 2 ports	+ : PoE P.D. present at ETH2	3G :UMTS

Available Model	Model Name	Description
	IGAR-1062+-3G_US	Industrial IEEE 802.11 a/b/g/n 3G Cellular router with 2x10/100/1000Base-T(X), 1-port PoE P.D., US band
	IGAR-1062+-3G_EU	Industrial IEEE 802.11 a/b/g/n 3G Cellular router with 2x10/100/1000Base-T(X), 1-port PoE P.D., EU band

Packing List

- **IGAR-1062+-3G**
- **2.4GHz/5GHz Antenna x 2**
- **3G Antenna x 1**
- **6-Pin Terminal Block x 1**
- **CD x 1**
- **Din-Rail Kit x 1**
- **5-Pin Terminal Block x 2**
- **Quick Installation Guide x 1**
- **Wall-Mount Kit x 2**
- **Dust Cover x 2**

Optional Accessories

- **DR-45 series : 45 Watts power supply**
- **DR-120 series : 120 Watts power supply**
- **RF Antenna Base (Magnetic) series**
- **DR-75 series : 75 Watts power supply**
- **WLAN RF Antenna (Omni-directional) series**
- **RF Cable series**