

ULTRA-LOW VOLTAGE DCDC BOOST CONVERTER FOR THERMAL ELECTRICAL GENERATORS

EM8900

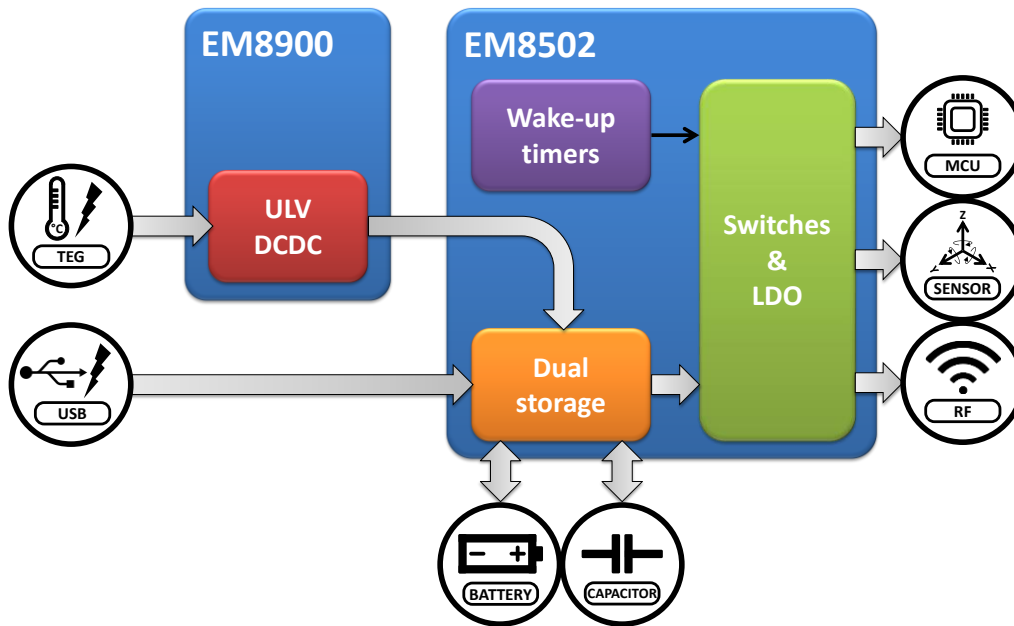

DESCRIPTION

The EM8900 is an integrated ultra-low power DCDC converter specifically designed for the Thermal Electrical Generators (TEG). The device starts and operates autonomously with an input voltage of as low as 5mV in the μ W to mW range. No additional supply voltage is required to start the DCDC.

This ultra-low voltage operating level allows using a TEG with a low Seebeck coefficient, thus reducing its mechanical size and cost.

The boost converter is inductive and uses a standard transformer, such as the LPR6235 series by Coilcraft.

The EM8900, coupled with the EM8502, offers a complete power management solution including the thermal energy harvesting, the energy storage supervising and the supply outputs controlling.

FEATURES

- | Ultra-low voltage DCDC operating and starting-up down to **V_{in} = 5mV** without help from external supply
- | Optimized for low-cost and small TEG's
- | Compatible with standard transformer from the market
- | Adapted to the EM8502 for a complete power management solution

APPLICATIONS

- | Thermal electrical generator harvesting
- | Wearable devices supplied by the body heat
- | Beacons and wireless sensor networks
- | Industrial and environmental monitoring
- | Battery operated platforms





TABLE OF CONTENTS

1. Product description	4
1.1. Operating modes	4
1.2. Block diagram	4
2. Handling Procedures	5
3. Pin description	5
4. Electrical specifications	6
4.1. Absolute Maximum Ratings	6
4.2. Operating Conditions	6
4.3. Electrical Characteristics	6
5. Typical Characteristics	7
5.1. Efficiency	7
5.2. Input impedance	8
6. Typical Application	9
6.1. Schematic example	9
6.2. Transformator selection guidelines	10
6.2.1. Transformer references	10
6.3. TEG selection guidelines	10
6.3.1. Thermal resistivity	10
6.3.2. Electrical resistivity	10
6.3.3. Seebeck coefficient	10
6.3.4. Teg selection example 1	11
6.3.5. Teg selection example 2	11
6.4. Capacitor selection	11
6.4.1. Input capacitor C_{HRV}	11
6.4.2. Coupling capacitor C_{AC}	12
6.4.3. Coupling capacitor C_{FB}	12
6.4.4. Output capacitor C_{DCDC}	12
7. Ordering Information	13
8. packaging Information	13
8.1. DFN10 3x3 package	13
8.2. Package marking	13



LIST OF FIGURES

Figure 1-1 EM8900 Block Diagram	4
Figure 5-1 DCDC Efficiency vs Input Voltage (T 1:20).....	7
Figure 5-2 DCDC Efficiency vs Input Power (T 1:20).....	7
Figure 5-3 DCDC Efficiency vs Input Voltage (T 1:50).....	7
Figure 5-4 DCDC Efficiency vs Input Power (T 1:50).....	7
Figure 5-5 DCDC Efficiency vs Input Voltage (T 1:100).....	7
Figure 5-6 DCDC Efficiency vs Input Power (T 1:100).....	7
Figure 5-7 Input Impedance vs Power No C _{FB}	8
Figure 5-8 Input Impedance vs Power C _{FB} 270 pF	8
Figure 5-9 Input Impedance vs Power C _{FB} 100 pF	8
Figure 5-10 Input Impedance vs Power C _{FB} 47 pF	8
Figure 5-11 Input Impedance vs Power C _{FB} 33 pF	8
Figure 5-12 Input Impedance vs Power C _{FB} 22 pF	8
Figure 5-13 Input Impedance vs Power C _{FB} 18 pF	8
Figure 6-1 Application Example	9
Figure 8-1 DFN10 Mechanical Information	13

LIST OF TABLES

Table 1 Pin-out description	5
Table 2 Absolute maximum ratings.....	6
Table 3 Operating Conditions	6
Table 4 Electrical Specifications	6
Table 5 Component List.....	9
Table 6 List of Reference Inductors	10
Table 7 C _{HRV} Capacitor Selection	11
Table 8 C _{FB} Capacitor Selection	12
Table 9 Ordering Information.....	13

1. PRODUCT DESCRIPTION

The EM8900 is an ultra-low voltage DCDC converter optimized for thermal electrical energy harvesting applications. An external transformer is used to boost the input voltage. The pin VSUP delivers the output voltage supply to the application. There is no limiter or regulator integrated in the device. The load, connected to VSUP, regulates and limits that voltage. The input pin DIS, allows stopping the DCDC boost converter when the maximum voltage allowed on VSUP is reached.

The EM8900 is designed to interface with the EM8502. In such a combination the EM8502 regulates and limits the DCDC output voltage automatically without additional external control.

1.1. OPERATING MODES

The EM8900 has 2 operating mode:

- Enabled
 - Input pin DIS is connected to the ground.
 - DCDC pump is running as long as an input voltage is present.
 - Energy is transferred to VSUP
- Disabled
 - Input pin DIS is at logical level '1'.
 - DCDC pump is in idle mode and no energy is transferred to VSUP.

1.2. BLOCK DIAGRAM

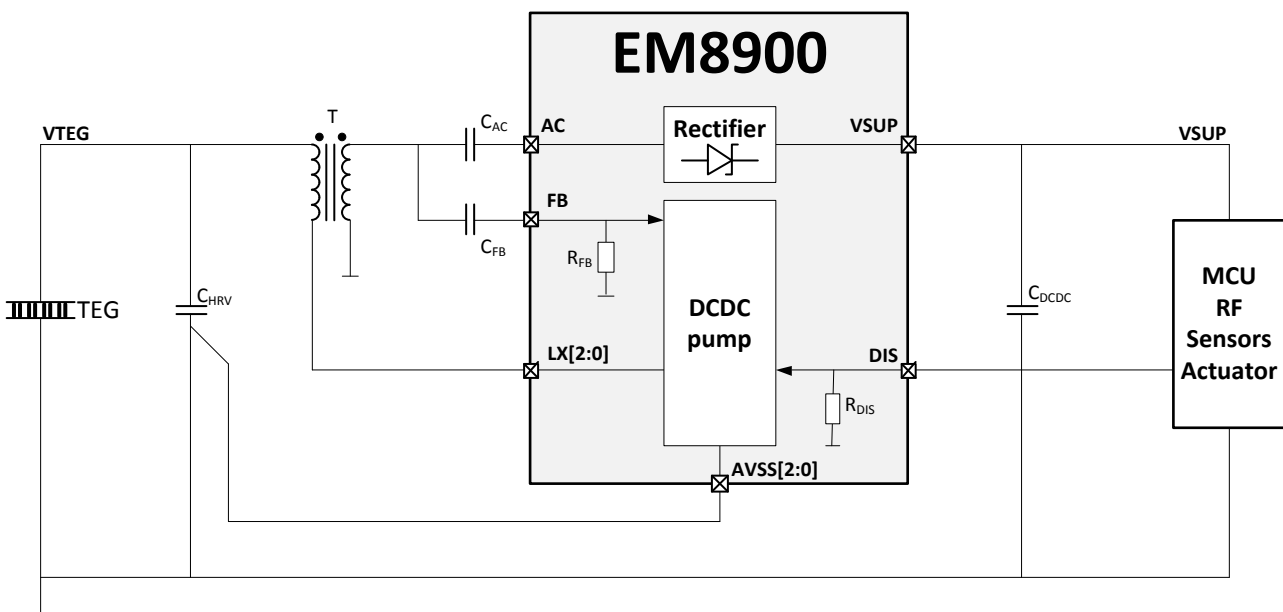

Figure 1-1 EM8900 Block Diagram



2. HANDLING PROCEDURES

This device has built-in protection against high static voltages or electric fields; however, anti-static precautions must be taken as for any other CMOS component. Unless otherwise specified, proper operation can only occur when all terminal voltages are kept within the voltage range. Unused inputs must always be tied to a defined logic voltage level.

3. PIN DESCRIPTION

PIN		I/O TYPE		DESCRIPTION
NO.	NAME	DIRECTION	SUPPLY	
1	AC	Input	-	Rectifier input
2	FB	Input	-	DCDC switching control
3	LX2	Input	-	Transformer primary side connection
4	LX1	Input	-	Transformer primary side connection
5	LX0	Input	-	Transformer primary side connection
6	AVSS0	Supply	-	Device ground connection
7	AVSS1	Supply	-	Device ground connection
8	AVSS2	Supply	-	Device ground connection
9	DIS	Supply	Up to 4.2V	DCDC boost converter disabled (when set to '1')
10	VSUP	Supply	VSUP	Supply output

Table 1 Pin-out description



4. ELECTRICAL SPECIFICATIONS

4.1. ABSOLUTE MAXIMUM RATINGS

PARAMETER	VALUE		UNIT	
	MIN	MAX		
Power supply VSUP	-0.2	5.0	V	
Input voltage on DIS	VSS-0.2	5.0	V	
Maximum voltage swing on LX0, LX1, LX2	-0.2	2.3	V	
Maximum voltage swing on FB	-2.3	2.3	V	
Maximum voltage swing on AC	-0.7	5.5	V	
Storage Temperature Range (T _{STG})	-65	150	°C	
Electrostatic discharge to ANSI/ESDA/JEDEC JS-001-2014 for HBM	Pin FB	-1000	1000	V
	All other pins	-2000	2000	V

Table 2 Absolute maximum ratings

Stresses above these listed maximum ratings may cause permanent damage to the device. Exposure beyond specified operating conditions may affect device reliability or cause malfunction.

4.2. OPERATING CONDITIONS

PARAMETER	SYMBOL	MIN	TYP	MAX	UNIT
Output supply limitation	V _{SUP}			4.2	V
Swing on DIS	V _{DIS}	0		4.2	V
Swing on LX0, LX1, LX2	V _{LX}	0		2.0	V
Swing on FB	V _{FB}	-2.0		2.0	V
Swing on AC	V _{AC}	-0.4		4.6	V
Coupling capacitor from transformer to rectifier	C _{AC}	0.1			µF
Coupling capacitor from transformer to DCDC boost	C _{FB}	10			pF
Decoupling input capacitor	C _{HRV}	100			µF
Decoupling output capacitor	C _{DCDC}	1			µF
Temperature range	T _R	-40		85	°C

Table 3 Operating Conditions

4.3. ELECTRICAL CHARACTERISTICS

Unless otherwise specified: T_A=-40°C to +85°C for min max specifications and T_A= 25°C for typical specifications.

PARAMETER	SYMBOL	CONDITIONS	MIN	TYP	MAX	UNIT
Minimum start-up TEG voltage	V _{TEG_SU}	Transformer: LPR6235-752SMR (1:100)		5		mV
Minimum operating TEG voltage	V _{TEG_OP}	Transformer: LPR6235-752SMR (1:100)		5		mV
Maximum TEG voltage	V _{TEG_MAX}			200		mV
Maximum output power	P _{OUT}	Transformer: LPR6235-752SMR (1:100)		20		mW
INTERFACE PARAMETERS						
DIS-HVMOS output drive	I _{OL_DIS}	V _{OL} (AC) = 0.3V ; DIS = 1.2V	0.5			mA
DIS-HVMOS leakage	I _{OFF_DIS_25}	AC = 4.2V ; DIS = 0V @ T _A = 25°C		250	1000	nA
DIS-HVMOS leakage	I _{OFF_DIS_95}	AC = 4.2V ; DIS = 0V @ T _A = -40°C to +85°C		250	30	µA
Input DIS - low level	V _{IL_DIS}				0.3	V
Input DIS - high level	V _{IH_DIS}		1.5			V
Input DIS - pull-down	R _{DIS}			48		MΩ
Input FB – pull-down	R _{FB}			11		MΩ
INTERFACE PARAMETERS						
DCDC Input impedance at 100µW	R _{IN_1:20_100µW}	Transformer: LPR6235-253PMR (1:20) Pin 100µW ; C _{FB} 33pF ; V _{out} 3.6V		8.7		Ω
DCDC Input impedance at 100µW	R _{IN_1:50_100µW}	Transformer: LPR6235-123QMR (1:50) Pin 100µW ; C _{FB} 33pF ; V _{out} 3.6V		3.8		Ω
DCDC Input impedance at 100µW	R _{IN_1:100_100µW}	Transformer: LPR6235-752SMR (1:100) Pin 100µW ; C _{FB} 33pF ; V _{out} 3.6V		2		Ω
DCDC Input impedance at 1mW	R _{IN_1:20_1mW}	Transformer: LPR6235-253PMR (1:20) Pin 1mW ; C _{FB} 33pF ; V _{out} 3.6V		2.9		Ω
DCDC Input impedance at 1mW	R _{IN_1:50_1mW}	Transformer: LPR6235-123QMR (1:50) Pin 1mW ; C _{FB} 33pF ; V _{out} 3.6V		1.3		Ω
DCDC Input impedance at 1mW	R _{IN_1:100_1mW}	Transformer: LPR6235-752SMR (1:100) Pin 1mW ; C _{FB} 33pF ; V _{out} 3.6V		0.87		Ω

Table 4 Electrical Specifications

5. TYPICAL CHARACTERISTICS

5.1. EFFICIENCY

C_{FB} is selected according to Table 8

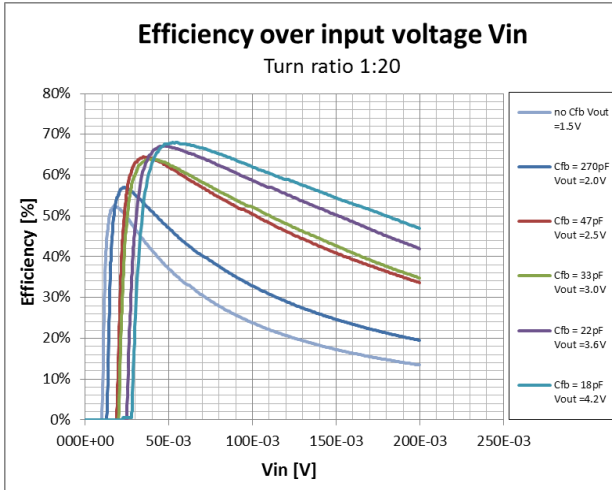

Figure 5-1 DCDC Efficiency vs Input Voltage (T 1:20)

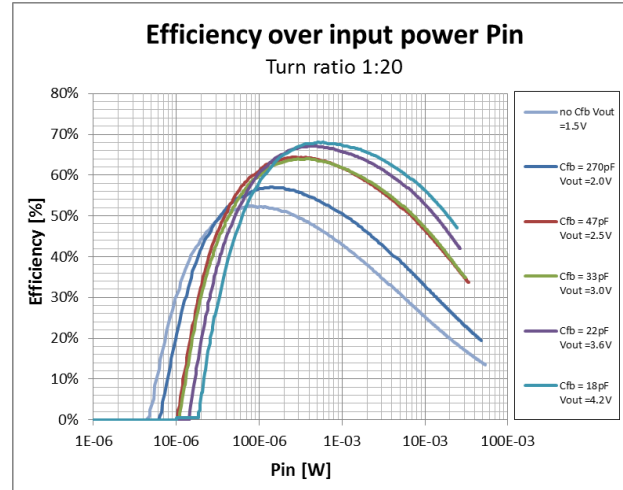

Figure 5-2 DCDC Efficiency vs Input Power (T 1:20)

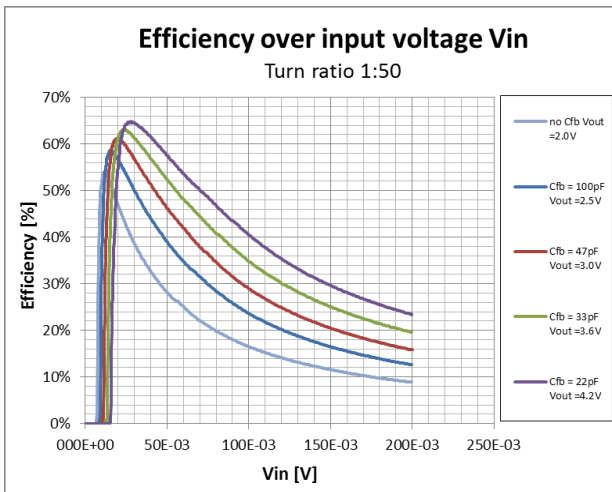

Figure 5-3 DCDC Efficiency vs Input Voltage (T 1:50)

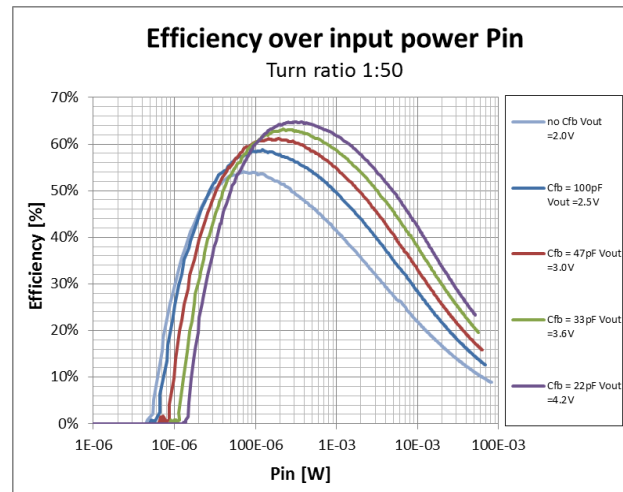

Figure 5-4 DCDC Efficiency vs Input Power (T 1:50)

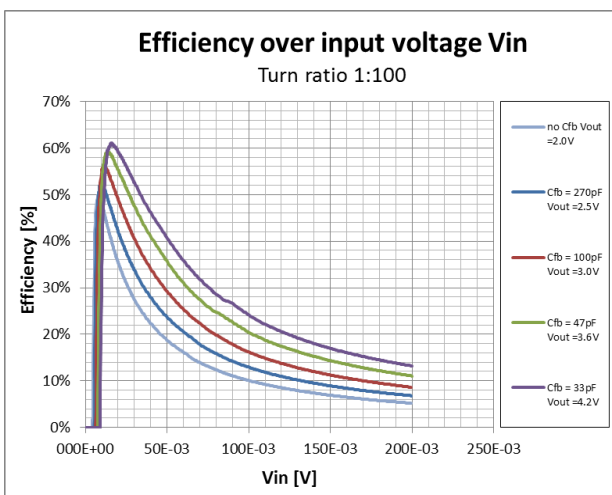

Figure 5-5 DCDC Efficiency vs Input Voltage (T 1:100)

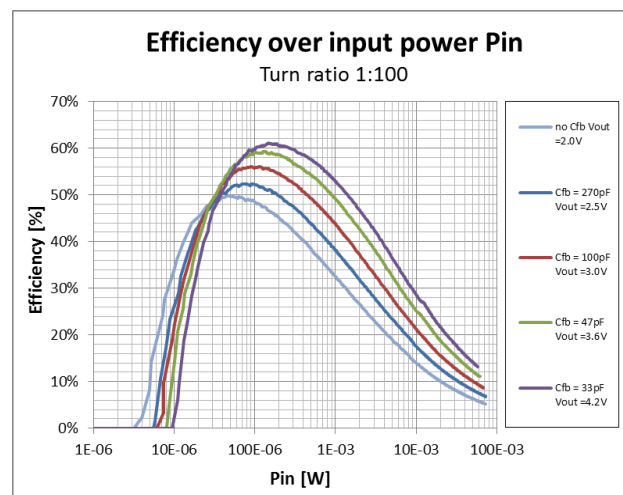

Figure 5-6 DCDC Efficiency vs Input Power (T 1:100)

5.2. INPUT IMPEDANCE

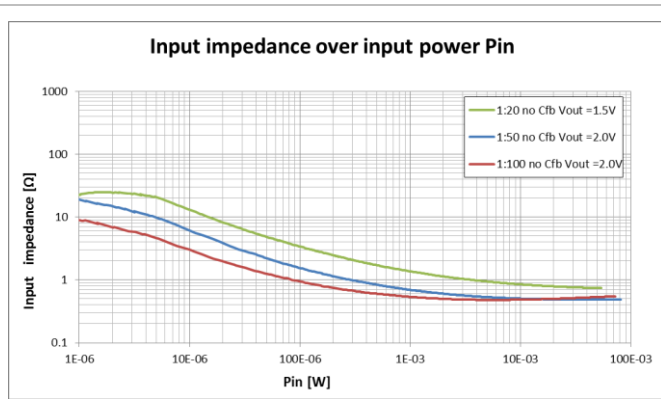

Figure 5-7 Input Impedance vs Power No C_{FB}

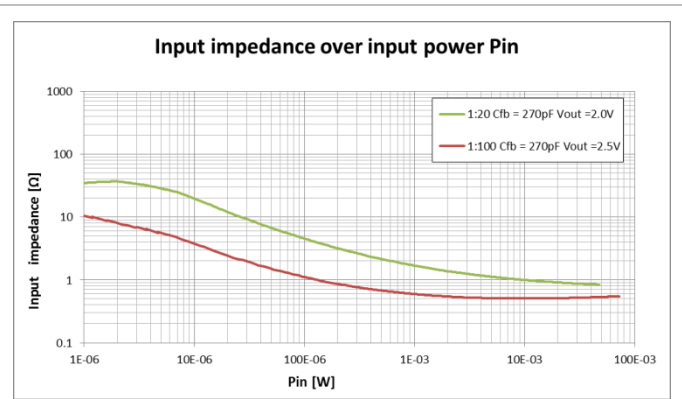

Figure 5-8 Input Impedance vs Power C_{FB} 270 pF

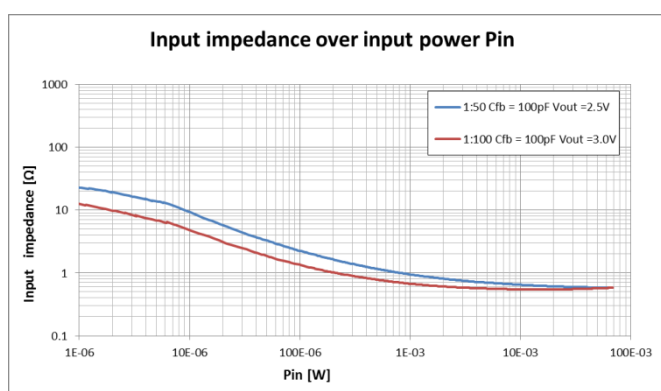

Figure 5-9 Input Impedance vs Power C_{FB} 100 pF

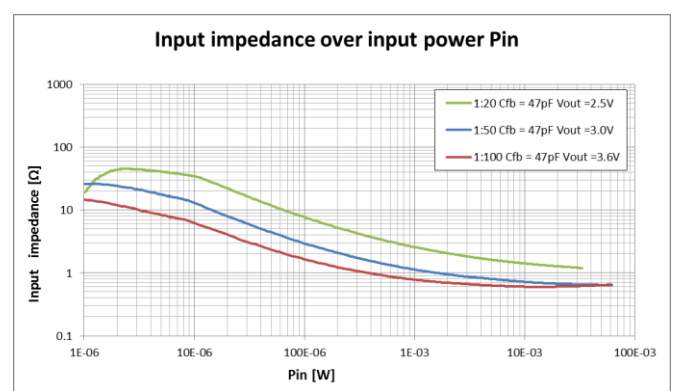

Figure 5-10 Input Impedance vs Power C_{FB} 47 pF

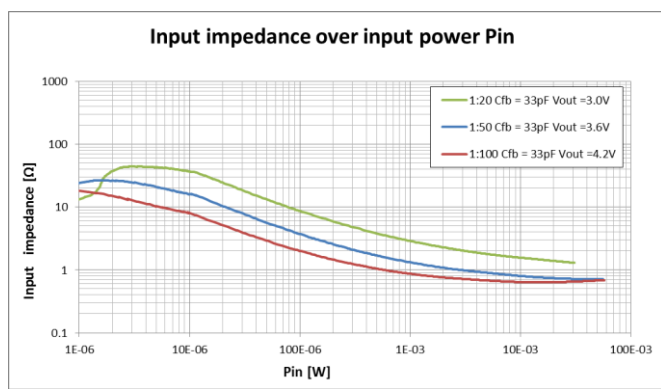

Figure 5-11 Input Impedance vs Power C_{FB} 33 pF

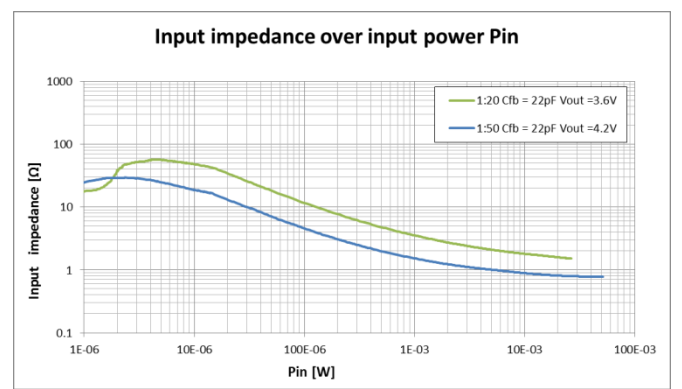

Figure 5-12 Input Impedance vs Power C_{FB} 22 pF

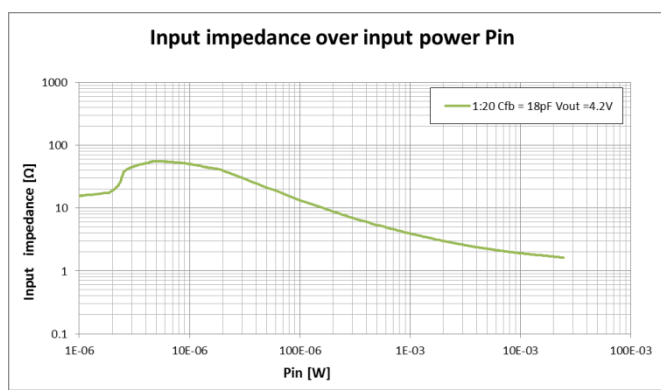

Figure 5-13 Input Impedance vs Power C_{FB} 18 pF

6. TYPICAL APPLICATION

6.1. SCHEMATIC EXAMPLE

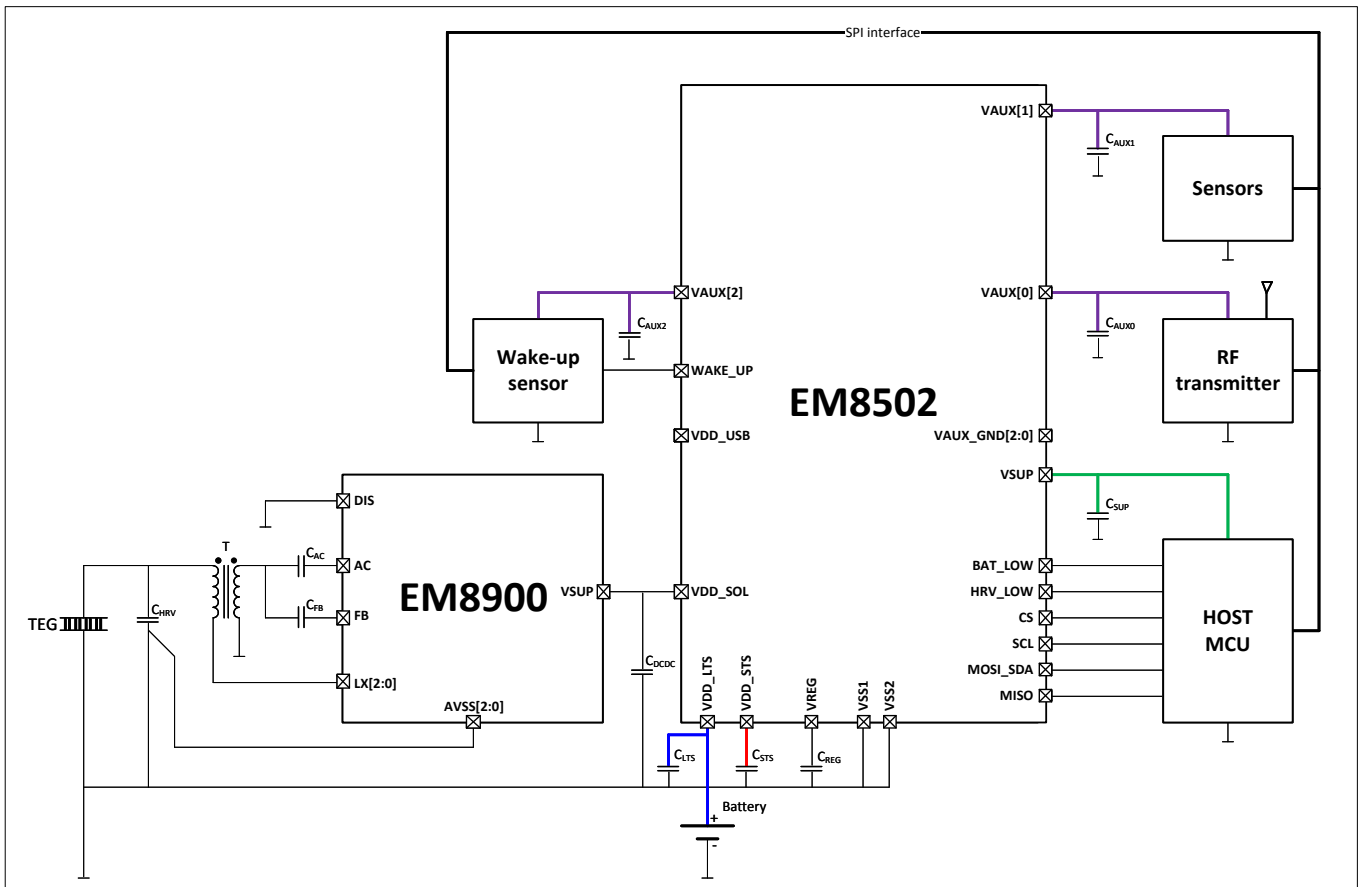

Figure 6-1 Application Example

Component	Symbol	Value
Harvester capacitor	C _{HRV}	100 μ F
Transformer	T	1:20 turn ratio
Coupling capacitor from transformer to rectifier	C _{CAC}	2.2 μ F
Coupling capacitor from transformer to DCDC boost	C _{FB}	33 pF
DCDC output capacitor	C _{DCDC}	2.2 μ F
LTS capacitor	C _{LTS}	10 μ F
STS capacitor	C _{STS}	220 μ F
Regulator capacitor	C _{REG}	470 nF
Main supply output capacitor	C _{SUP}	1 μ F
Auxiliary (0) supply output capacitor	C _{AUX0}	1 μ F
Auxiliary (1) supply output capacitor	C _{AUX1}	1 μ F
Auxiliary (2) supply output capacitor	C _{AUX2}	1 μ F

Table 5 Component List

6.2. TRANSFORMATOR SELECTION GUIDELINES

The DCDC converter requires a properly selected transformer to obtain the highest efficiency. The following criteria are important:

- Turn ratio
 - 1:20 is very efficient especially in high power level
 - 1:50 is a compromise between minimum start-up voltage and efficiency
 - 1:100 allows starting-up at very low voltage and get a good efficiency in ultra-low power level
- The DC resistivity on primary side is important for application operating at high power level.
- The saturation current level on primary side shall be at least 30% higher than the maximum input peak current

6.2.1. TRANSFORMER REFERENCES

Manufacturer	Turn ratio	Size			RDC		Isat primary	Part number	Comments
		Length	Width	Thickness	primary	secondary			
Coilcraft	1:20	6mm	6mm	3.5mm	200mΩ	72Ω	0.7 A	LPR6235-253PMR	High efficiency at mid-high power level
Coilcraft	1:50	6mm	6mm	3.5mm	85mΩ	200Ω	0.9 A	LPR6235-123QMR	Compromise between low input voltage and high efficiency at mid power level
Coilcraft	1:100	6mm	6mm	3.5mm	85mΩ	340Ω	1.6 A	LPR6235-752SMR	Ultra-low input voltage and high efficiency at low power level

Table 6 List of Reference Inductors

6.3. TEG SELECTION GUIDELINES

TEG selection is important to optimize efficiency of the DCDC conversion. Thermal and electrical aspects must be considered.

6.3.1. THERMAL RESISTIVITY

6.3.1.1. STRONG THERMAL COUPLING ON BOTH SIDES OF THE TEG

TEG element is solidly connected to the hot and cold thermal sources. For instance, the TEG is directly attached to hot and cold water pipes. The best would be to select a TEG with the smallest possible thermal resistivity. The thermal flux will be higher. With a very low thermal resistivity between the TEG and the pipes, nearly the full temperature gradient can be utilized by the TEG.

6.3.1.2. COOLING ELEMENT CONNECTED TO THE TEG

A common application is to harvest the thermal energy between a hot source and the ambient temperature. In this configuration the thermal coupling to the ambient temperature is not ideal. A cooling element is attached to bring the cold pole of the TEG as close as possible to ambient temperature. Usually the cooling element resistivity is limited by the available mechanical size, airflow or esthetical criteria. The thermal resistivity of TEG and cooling element have to match for maximum power extraction.

6.3.2. ELECTRICAL RESISTIVITY

The TEG electrical impedance and the EM8900 input impedance have to match as shown in Figure 5-7 to Figure 5-13. As a function of the operating power range, the TEG electrical impedance should be selected as closely as possible to the value shown.

6.3.3. SEEBECK COEFFICIENT

After selecting the TEG thermal and electrical resistivity, the Seebeck coefficient is usually set by the TEG manufacturer. The maximum V_{TEG} level is V_{TEG_MAX} (see Table 4). For TEG elements with higher V_{TEG} values, the EM8500 product is more suitable for such an application (see <http://www.emmicroelectronic.com/products/power-management/pmu-dc-energy-harvesting-controller/em8500>).

6.3.4. TEG SELECTION EXAMPLE 1

This example assumes an industrial application operated with a TEG element attached to a hot water pipe on the hot side and connected to a cooling element of 10 [K/W] in ambient air on the cold side.

The electronic system requires an average power of 1 mW and must operate fully autonomously. The maximum output voltage is 4.2V.

We arrive at the following selection of parameter values:

1. The best transformer turn ratio in this power range is 1:20
2. The ideal TEG thermal resistivity is 10 [K/W]
3. According to the Table 8, C_{FB} is 18 pF ($V_{OUT} = 4.2V$; Turn ratio = 1:20)
4. According to the Figure 5-13, the ideal TEG electrical resistivity is about 4 Ω at 1 mW.

The following TEG by Marlow offers characteristics close these values:

Part number: **NL1023T-01AC**
 Thermal resistivity: **11.30 [K/W]**
 Electrical resistivity: **3.50 [Ω]**
 Seebeck coefficient: **27 [mV/K]**

6.3.5. TEG SELECTION EXAMPLE 2

This application example assumes a wearable device in contact with the skin on the hot side and TEG with a cooling element of 100 [K/W] in ambient air. The electronic system requires an average power of 20 μ W and operates fully autonomously. The maximum output voltage is 2.0V.

1. The best turn ratio for the transformer in this power range is 1:100
2. The ideal TEG thermal resistivity is 100 [K/W]
3. According to the Table 8, no C_{FB} is required (secondary side of transformer is directly connected to FB)
4. According to the Figure 5-7, the ideal TEG electrical resistivity is about 2 Ω at 20 μ W.

The following TEG by Marlow offers characteristics close to these values when 2 elements are electrically connected in series and thermally connected in parallel:

Part number:	1x NL1010T-01AC	2x NL1010T-01AC
Thermal resistivity:	191.40 [K/W]	95.7 [K/W]
Electrical resistivity:	0.64 [Ω]	1.28 [Ω]
Seebeck coefficient:	2.665 [mV/K]	5.33 [mV/K]

6.4. CAPACITOR SELECTION

6.4.1. INPUT CAPACITOR C_{HRV}

The capacitor C_{HRV} acts as a charge bank and reduces the input voltage ripple and therefore ohmic loss in the TEG. The size of that capacitor depends on the current amplitude in the primary side of the transformer, the input voltage average and the internal resistivity of the TEG (R_{TEG}). Higher is the current; higher must be C_{HRV} for a given V_{TEG} and R_{TEG} . We advise selecting C_{HRV} as follows:

Input power range	Recommended C_{HRV} value
Up to 100 μ W	47 μ F
100 μ W to 1 mW	100 μ F
Above 1 mW	470 μ F

Table 7 C_{HRV} Capacitor Selection

6.4.2. COUPLING CAPACITOR C_{AC}

The capacitor C_{AC} coupled the AC part of the signal from the secondary side of the DCDC to the rectifier. The bigger value of that capacitor is the best especially in high power range. 2.2 μF covers all power range, 1 μF is enough for a maximum power of 100 μW .

6.4.3. COUPLING CAPACITOR C_{FB}

The capacitor C_{FB} reduces the voltage swing applied on FB and depends on the maximum V_{OUT} voltage level and the turn ratio of the transformer. The minimum start-up voltage increases when C_{FB} is small, but at high power level the efficiency slightly increases when C_{FB} is smaller.

Maximum output voltage V_{OUT}	Recommended C_{FB} value		
	Transfo turn ratio 1:20	Transfo turn ratio 1:50	Transfo turn ratio 1:100
1.5 V	C_{FB} not required	C_{FB} not required	C_{FB} not required
1.8 V	270 pF	C_{FB} not required	C_{FB} not required
2.4 V	47 pF	100 pF	270 pF
3.0 V	33 pF	47 pF	100 pF
3.6 V	22 pF	33 pF	47 pF
4.2 V	18 pF	22 pF	33 pF

Table 8 C_{FB} Capacitor Selection

6.4.4. OUTPUT CAPACITOR C_{DCDC}

We advise to use 2.2 μF as output capacitor C_{DCDC} .

7. ORDERING INFORMATION

Part Nb	Package form	Delivery form
EM8900-V001-DFN10B+	DFN10 3x3 mm	Tape & Reel

Table 9 Ordering Information

For other delivery formats please contact an EM Microelectronic-Marin SA representative.

8. PACKAGING INFORMATION

8.1. DFN10 3X3 PACKAGE

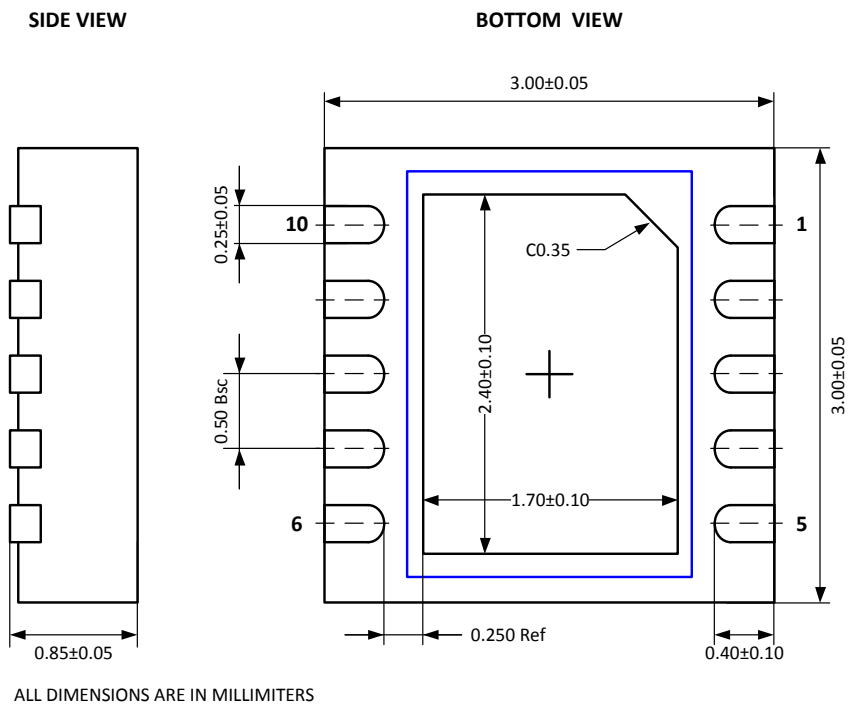

Figure 8-1 DFN10 Mechanical Information

8.2. PACKAGE MARKING

The EM8900 package markings are shown below.

Additional marking letters and numbers are used for EM internal product traceability.

8	9	0	0	0
0	1			



EM Microelectronic-Marín SA ("EM") makes no warranties for the use of EM products, other than those expressly contained in EM's applicable General Terms of Sale, located at <http://www.emmicroelectronic.com>. EM assumes no responsibility for any errors which may have crept into this document, reserves the right to change devices or specifications detailed herein at any time without notice, and does not make any commitment to update the information contained herein.

No licenses to patents or other intellectual property rights of EM are granted in connection with the sale of EM products, neither expressly nor implicitly.

In respect of the intended use of EM products by customer, customer is solely responsible for observing existing patents and other intellectual property rights of third parties and for obtaining, as the case may be, the necessary licenses.

Important note: The use of EM products as components in medical devices and/or medical applications, including but not limited to, safety and life supporting systems, where malfunction of such EM products might result in damage to and/or injury or death of persons is expressly prohibited, as EM products are neither destined nor qualified for use as components in such medical devices and/or medical applications. The prohibited use of EM products in such medical devices and/or medical applications is exclusively at the risk of the customer.