



11/14/14

**FEATURES**

- User-programmable 24-hour, 7-day digital timer
- 15 different program periods built in: Full week, 7 individual days and 7 multiple-day combinations
- Set automatic On/Off cycles; use manual override when needed
- Real-time 24/7 accuracy to the minute
- 12-hour am/pm clock format
- Set up to 8 On/Off cycles per day
- On board LED power indicator
- LCD display shows ON and OFF status
- Memory backup with onboard battery
- 20 Amp resistive switching capability, maximum
- Choice of 6 voltages: 120VAC, 230VAC, 24VAC/VDC, 12VAC/VDC
- Clear protective cover included
- UL and CE approvals, RoHS compliant

**SPECIFICATIONS**

- Dimensions** ..... in inches 2<sup>3</sup>/<sub>8</sub>H x 2<sup>3</sup>/<sub>8</sub>W x 1<sup>3</sup>/<sub>8</sub>D  
in mm 60H x 60W x 37D
- Supply voltage ranges** .... 100–130VAC, 200–250VAC, 24VAC/VDC, 12VAC/VDC
- Operating accuracy** ..... ±1 second/day at 20°C
- Operating temperature** ... -10°C to +55°C
- Standards** ..... UL, CE, RoHS, CUR E166259



**BUTTON FUNCTIONS**

- Press **(P)** RESET button to reset timer before using.
- CLOCK:** Press/hold to set current time with Day, Hour, Min buttons. Press to commence program execution after setting.
- TIMER:** Press to enter program mode, and to review up to 8 total programmed on/off cycles.
- DAY:** In Clock mode, sets the current day of the week. In Timer mode, selects the built-in program period desired.
- HOUR:** Sets the hour.
- MIN:** Sets the minutes.
- MANUAL:** Press to select ON/AUTO/OFF mode indicator.
- RESET:** Press to Cancel all settings. Recessed button next to **(P)**. Depress with pencil or ballpoint pen.
- ON:** Red LED indicator is lit when the internal relay is energized, closing the Common (3) to NO (5) terminal.

**WARNING:** Do not bring the hot and neutral to 3 and 5 without a load. This will cause a catastrophic failure to the timer. This is not covered by warranty.

**NOTE:** The voltage to the load does not need to be the same as the voltage to power the timer.

**619 TIMER OPTIONS**

- 619-1** 100–130VAC
- 619-2** 200–250VAC
- 619-3** 24VAC/VDC
- 619-4** 12VAC/VDC
- 619-BRKT** Mounting bracket

**TYPICAL WIRING EXAMPLE**

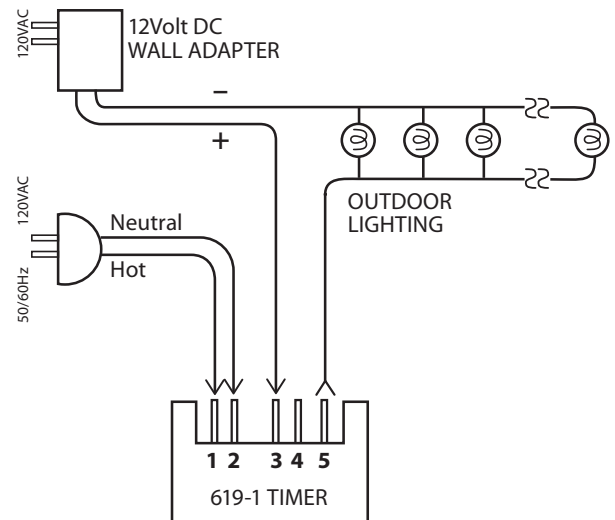

INSTALLING AND PROGRAMMING THE TIMER

**RESET BUTTON** To clear all settings, push in the the Reset Button with a small pointed object. Reset button is above Min button and to the right of (P). Pressing buttons advance forward only.

**SET THE CLOCK** Press and hold the Clock button. Press the Day button until correct day is displayed. Press the Hour button until correct hour is displayed. AM or PM is visible in the upper left. Press the Min button until correct minute is displayed. Release the Clock button. Clock is set.

**SET THE TIMER** Plan ahead and use care when setting. To change any or all On/Off times, timer must be reset first. "Correcting" just one setting is not possible.

Review the list of built-in Program Periods. Select the appropriate combination of days with common On-Off times. The timer can be set for more than one Program Period but all On-Off times will be the same for days within that program. Do not set conflicting times.

Examples: *Acceptable combination* 9) MoTuWeThFr and 10) SaSu  
*Unacceptable combination* 9) MoTuWeThFr and 14) MoWeFr

If choosing multiple Program Periods, up to 8 total On/Off settings are possible. If choosing a single Program Period up to 8 total On/Off settings per day are possible.

**SELECT THE PROGRAM PERIOD and SET ON-OFF TIMES**

Press Timer button. 1<sup>ON</sup> appears in the window. Next press Day to reach the desired Program Period. To select the first desired On time, Press Hour, then Min.

To select the first desired Off time, press Timer. 1<sup>OFF</sup> appears in the window. Next press Day to select the same Program Period. Press Hour, then Min, to select the first Off time.

Set up to 8 On-Off cycles by repeating the process for each On time and each Off time. Be sure to set Off time before choosing a different Program Period.

PROGRAM PERIODS							
1	MO	TU	WE	TH	FR	SA	SU
2	MO						
3		TU					
4			WE				
5				TH			
6					FR		
7						SA	
8							SU
9	MO	TU	WE	TH	FR		
10						SA	SU
11	MO	TU	WE	TH	FR	SA	
12	MO	TU	WE				
13				TH	FR	SA	
14	MO		WE		FR		
15		TU		TH		SA	

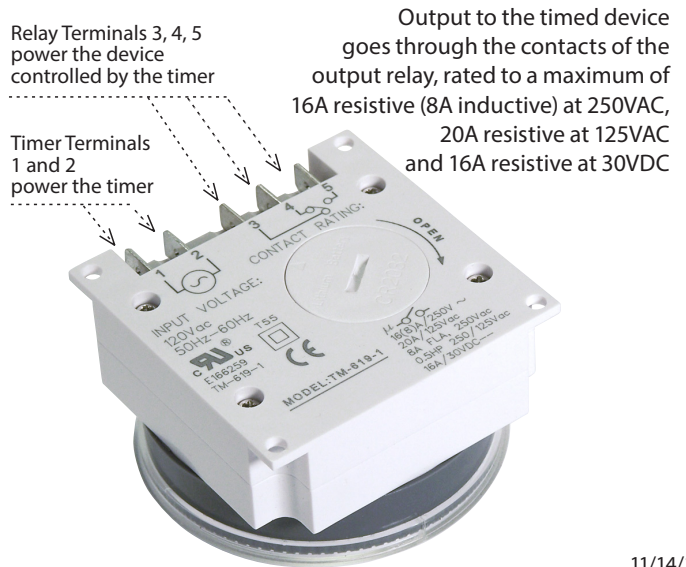

11/14/14

**COMPLETE AND CHECK TIMER SETTINGS**

Finally, press Clock to return to current time. Check that the Indicator line under the current time is above AUTO; if not press the Manual button until Auto is indicated. To confirm programmed settings, press Timer repeatedly to sequentially review all On-Off settings showing On times, Off times and Program Periods.

**OVERRIDE FUNCTIONS** Two override functions are available, effective only when timer is running in AUTO mode.

**"Anti-Burglar" Random Override** *Example:* When away, turn house lights or radio on and off in an unpredictable pattern. Press and hold the Day button, then press the Min button. (P) appears in lower left corner, indicating the timer is now in Random mode, overriding the Program settings and turning output to On every 10 to 120 minutes. To resume set programming, press and hold the Day button, then press the Min button. (P) no longer shows and programming returns.

**Maintenance or Emergency Override** In Auto mode, when timer is executing Program settings, two temporary override conditions can be employed.

- 1 Change output status from On to Off by pressing Manual button to move Indicator from Auto to Off. Press Manual again to return to Auto mode. Output remains Off until timer reaches next On setpoint.
- 2 Change output status from Off to On by pressing Manual button to move Indicator from Auto to On. Press Manual again to return to Auto mode. Output remains On until timer reaches next Off setpoint.

**BATTERY REPLACEMENT** The timer includes a standard CR2032 lithium button battery which keeps the time correct. Replace after 2 or 3 years, using a coin to remove the battery cover.