

DESCRIPTION

Demonstration circuit 811 is a dual output and dual (independent) input regulator, based on the LT3027 IC, which consists of two identical LDO linear regulators in one package. Each input has an input voltage range of 2.3V to 20V, and either output is capable of delivering up to 100 mA of output current. The DC supply current, per channel, is typically only 20 μ A at no load, and less than 0.1 μ A in shutdown. The LT3027EDD comes in a small 10 Pin DFN package, which has an exposed pad on the bottom-side of the

IC for better thermal performance. The DC811 comes assembled with small ceramic capacitors, showing the LT3027 ability to maintain stability with ceramic output capacitors. These ceramic bypass capacitors are on each output for extra low noise performance. These features make the DC811 an ideal circuit for use in battery-powered, hand-held applications or noise sensitive applications. **Design files for this circuit board are available. Call the LTC Factory.**

QUICK START PROCEDURE

The DC811 is easy to set up to evaluate the performance of the LT3027. For proper measurement equipment configuration, set up the circuit according to the diagram in Figure 1.

Please follow the procedure outlined below for proper operation.

1. Connect the input power supply to the Vin and GND terminals. Connect the loads between the Vout and GND terminals. Refer to figure 1 for proper measurement equipment setup.
2. Before proceeding to operation, insert jumpers JP1 and JP2 into the OFF positions, and jumpers JP3 and JP4 into the voltage options of choice (2.5V, 3.3V, and 5V).
3. Apply 6.5V at Vin. Measure both Vouts; they should read 0V.
4. Turn on Vout1 and Vout2 by changing jumpers JP1 and JP2 from the OFF positions to the ON positions. Both output voltages should be within a tolerance of +/- 2%.

5. Vary the input voltage from 6.5V to 20V. Both output voltages should be within +/- 3.3% tolerance.
6. Vary each load current from 0 to 100mA. Both output voltages should be within a tolerance of +/- 4%.
7. Observe both output voltages AC-coupled; they should measure noise voltages of less than 2 mVAC each. Refer to Figure 2 for proper measurement technique.
8. When finished, insert jumpers JP1 and JP2 to the OFF position(s) and disconnect the power.

Warning - If the power for the demo board is carried in long leads, the input voltage at the part could "ring", which could affect the operation of the circuit or even exceed the maximum voltage rating of the IC. To eliminate the ringing, insert a small tantalum capacitor (for instance, an AVX part # TAJW106M025R) on the pads between the input power and return terminals on the bottom of the demo board. The (greater) ESR of the tantalum will dampen the (possible) ringing voltage due to the use of long input leads. On a normal, typical PCB, with short traces, the capacitor is not needed.

QUICK START GUIDE FOR DEMONSTRATION CIRCUIT 811

DUAL OUTPUT LOW NOISE LDO REGULATORS

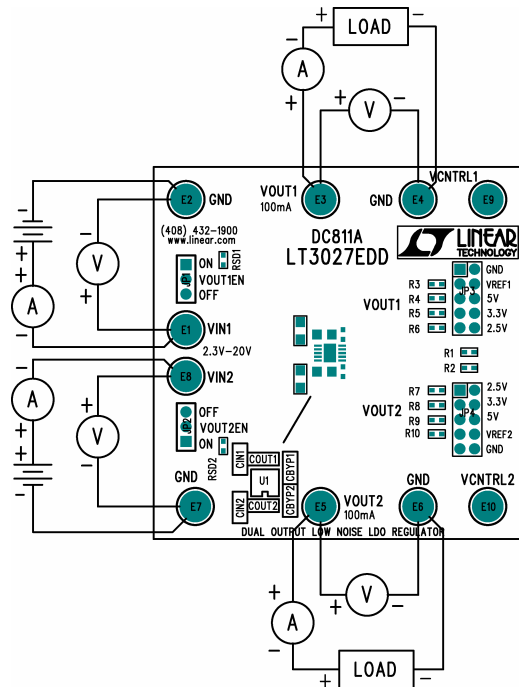

Figure1. Proper Measurement Equipment Setup

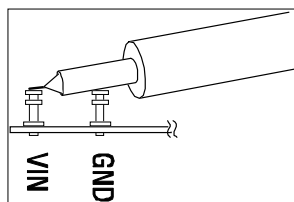

Figure 2. Measuring Input or Output Ripple

QUICK START GUIDE FOR DEMONSTRATION CIRCUIT 811

DUAL OUTPUT LOW NOISE LDO REGULATORS

This circuit is proprietary to Linear Technology and supplied for use with Linear Technology parts.

Customer Notice: Linear Technology has made a best effort to design a circuit that meets customer-specified specifications; however, it remains the customer's responsibility to verify proper and reliable operation in the actual application. Component substitution and printed circuit board layout may significantly affect circuit performance or reliability. Contact Linear Applications Engineering for assistance.

REVISION HISTORY				
ECO	REV	DESCRIPTION	DATE	APPROVED
	2	PROTO	07/28/04	

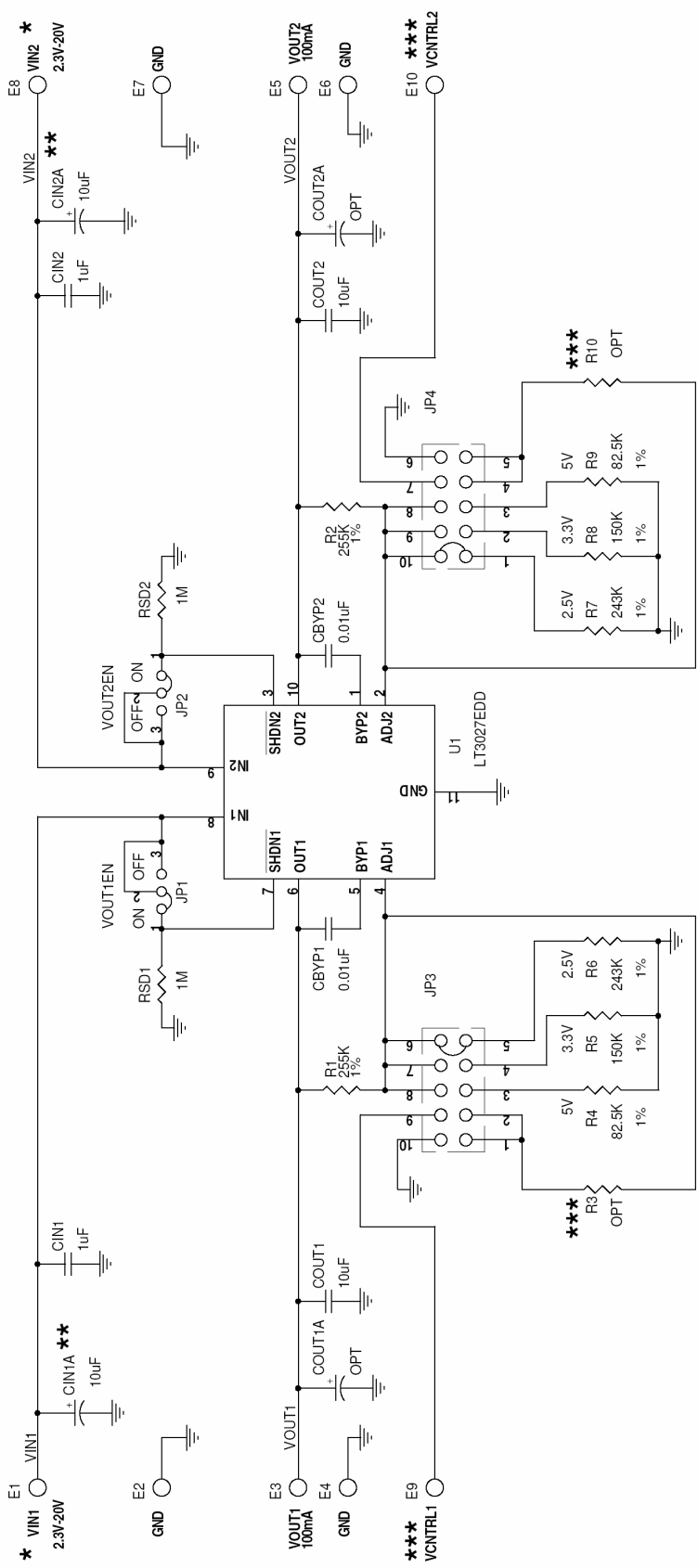

- * 2.3V IS THE MINIMUM INPUT VOLTAGE THAT LT3027EDD WILL OPERATE AT. THE MINIMUM INPUT VOLTAGE FOR A SPECIFIC REGULATOR CIRCUIT DEPENDS ON THE OUTPUT VOLTAGE PLUS THE DROP OUT VOLTAGE.
- ** CIN1A AND CIN2A ARE OPTIONAL CAPACITORS. THEY ARE ASSEMBLED ON THE DC811A TO DAMPEN THE (POSSIBLE) RINGING VOLTAGE DUE TO THE USE OF LONG INPUT LEADS. ON A NORMAL, TYPICAL PCB, WITH SHORT TRACES, CIN1A AND CIN2A ARE NOT NEEDED.
- *** THERE ARE TWO CHOICES WHEN UTILIZING USER SELECT. THE FIRST CHOICE IS A RESISTOR TO GROUND FOR SETTING AN OUTPUT VOLTAGE BETWEEN VIN AND THE REFERENCE VOLTAGE. THIS IS THE USUAL CONFIGURATION. THE SECOND CHOICE IS TO INSERT A RESISTOR TO VIN AND AN EXTERNAL CONTROL VOLTAGE, WHICH ALLOWS THE OUTPUT VOLTAGE TO BE SET AT VOLTAGES BELOW VREF. THE CIRCUIT NEEDS A MINIMUM LOAD CURRENT OF 1mA TO OPERATE PROPERLY IN THIS CONFIGURATION, SO SET R1 TO 1.21K.

CONTRACT NO.		DATE	
DRAWN: m1el	06/08/04	TITLE	
CHECKED		SCH, LT3027EDD, DUAL OUTPUT LOW NOISE LDO REGULATOR	
APPROVED		SIZE	CAGE CODE
ENGINEER		DWGNO	DC811A
DESIGNER		SCALE: NONE	FILENAME: 811A-2.DSN
Friday, October 01, 2004		SHEET	1 OF 1



1830 McCarthy Blvd.
Folsom, CA 95630
Tel: (916) 444-0000
Fax: (916) 444-2507