

ISOMETRIC
SEGMENT VIEW
1:1

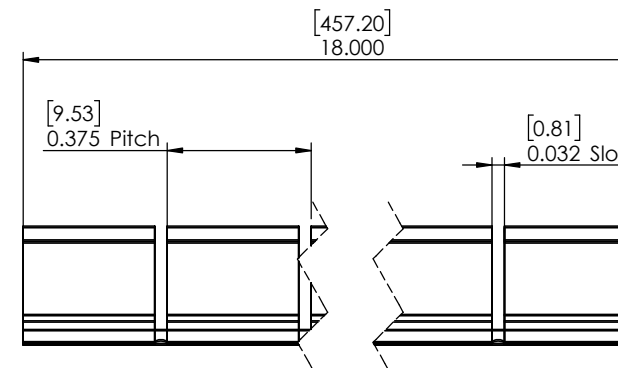
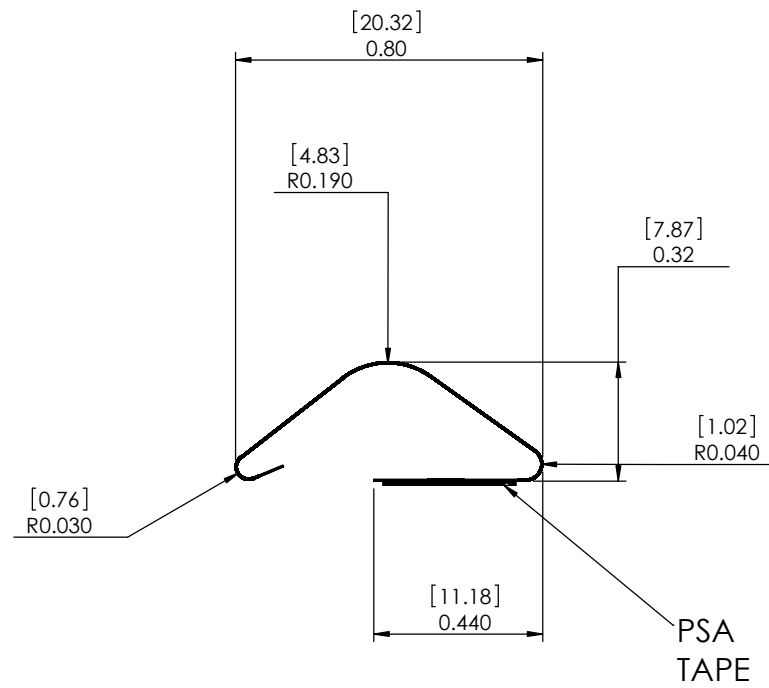
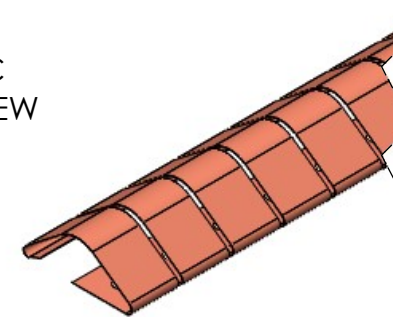

RoHS Compliant		DIMENSIONS ARE IN INCHES [MILLIMETERS]		NAME	DATE	
THIRD ANGLE PROJECTION		TOLERANCES:		DRAWN	TNC 12/17/2010	
DO NOT SCALE DRAWING		FRACTIONAL ±		CHECKED		
PROPRIETARY AND CONFIDENTIAL		ANGULAR: MACH ± 3 Degrees		ENG APPR.		
THE INFORMATION CONTAINED IN THIS DRAWING IS THE SOLE PROPERTY OF ORBEL CORPORATION. ANY REPRODUCTION IN PART OR AS A WHOLE WITHOUT THE WRITTEN PERMISSION OF ORBEL CORPORATION IS PROHIBITED.		TWO PLACE DECIMAL ± .015 [.381]		MFG APPR.		
		THREE PLACE DECIMAL ± .010 [.254]		Q.A.		
		MATERIAL:		COMMENTS:		
		.004" [.102] BeCu ALLOY 25, 1/2 HARD				
		FINISH:				
		WEIGHT: 0.507oz. [14.364g]				
SIZE	DWG NO.	REV.				
A	26B05-BFA018000T	01				
SCALE: 2:1	CAGE CODE: 57DU2	SHEET 1 OF 1				

HOW TO ORDER FINGER-STOCK GASKETS

The chart below is an easy-to-use reference on how Orbel finger-stock gasket part numbers are created and used to order standard and custom gaskets. Custom configurations that fall outside of our standard gasket styles are also available.

Sample Part Number: 30B09-BFA024000T

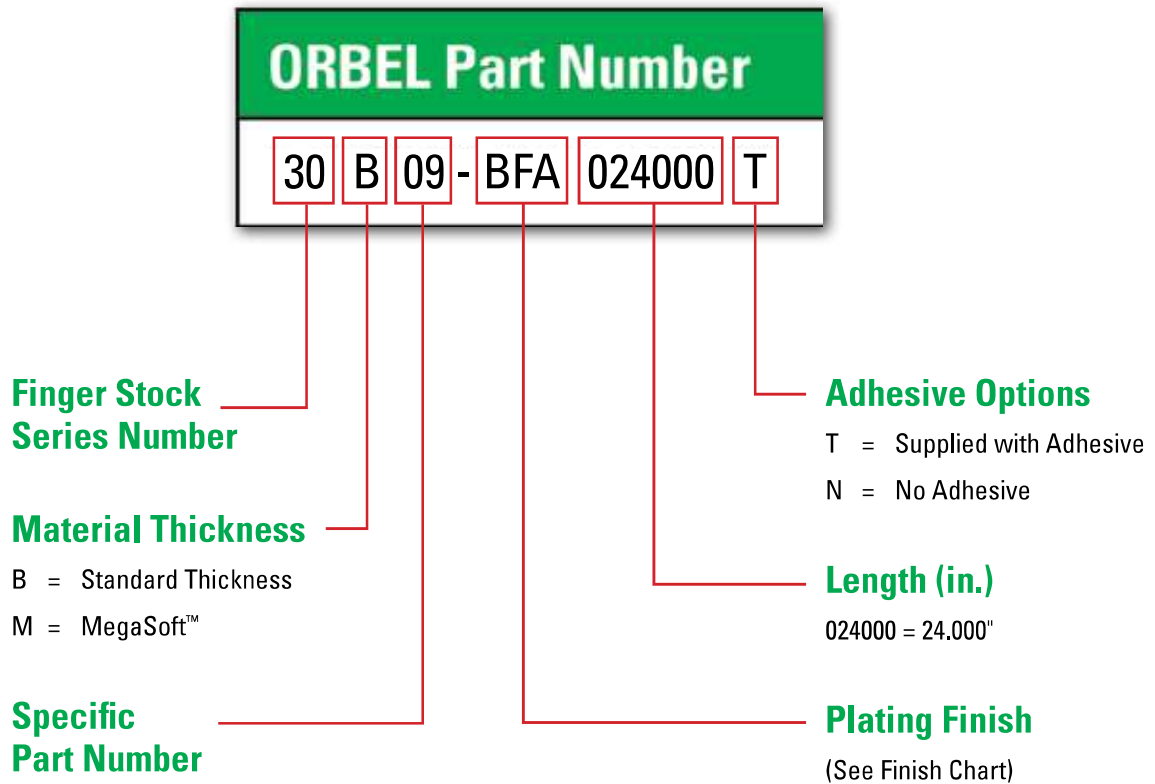

PLATING FINISHES			
Finish Type	Finish Code	Finish Type	Finish Code
SILVER	AGA	NICKEL, ELECTROLESS	NIP
GOLD .000050" MIN	AUA	TIN/LEAD 90/10, MATTE	PBA
GOLD .000050" MIN with NICKEL FLASH UNDERPLATE	AUK	TIN/LEAD 60/40, MATTE	PBB
BRIGHT FINISH, UNPLATED	BFA	TIN/LEAD 90/10, BRIGHT	PBC
BRIGHT FINISH, SOLDERABLE	BFS	TIN/LEAD 60/40, BRIGHT	PBD
CADMIUM + CLEAR CHROMATE	CDA	TIN, BRIGHT	SNA
CADMIUM + YELLOW CHROMATE	CDB	TIN, MATTE	SNB
NICKEL, BRIGHT	NIA	ZINC + CLEAR CHROMATE	ZNA
NICKEL, MATTE OR SULFAMATE NICKEL	NIB	ZINC + YELLOW CHROMATE	ZNB

All plating thicknesses are .0001" min. except where noted.