

**Rectangular Flashing Safety Light - 40° Tilt Activated, Fully Sealed**  
**Part Number : RBM-40**  
**Product Data Sheet**

**PICTURE**



**CE FC**

**ACTIVATION**

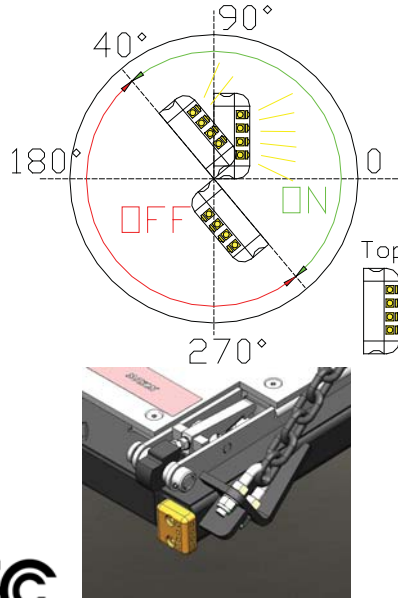

Recommened  
Mounting position

**DIMENSIONS**

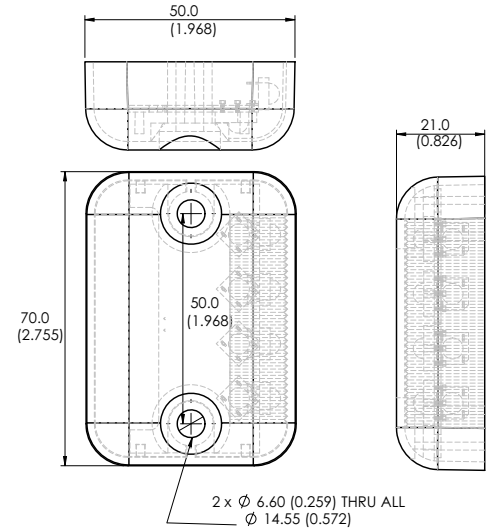

Drawings not to scale

**SPECIFICATION**

|                                   |           |  |
|-----------------------------------|-----------|--|
| Activation Angle                  | Degree    | 220° - 20°   |
| Battery Life                      |           | Up to 5 years (under normal conditions)                        |
| Number of LED'S                   |           | 8 total - 4 per side   |
| Operating Temperature             | Celcius   | -20° to 85° (-50°min, flash rate increased & lifetime reduced) |
| Flash Rate                        | Pulse/min | 60 at 20°  |
| Battery Voltage (non replaceable) | Volts     | 3.6  |
| Fixing Holes                      |           | 2 x 6.6mm (50mm centres)                                       |
| IP Rating                         |           | 68   |
| Material                          |           | Resin filled Polycarbonate Shell                               |

**Applications Include**

- Tail Lift / Ramp Safety Warning.
- Lorry Outrigger indication.
- Fork Lift Safety Warning.
- Hazardous Obstruction Warning.

**Options**

- Colour: Standard Amber
- Other colours available, please enquire.
- Customer specific activation angle and pulse rate.
- Number of LED'S / grouped led angles.
- If you do not see what you need, jusk ask, as there is a strong possibility we can do it !

**Did you know we also sell?**



**Rev. No.**

0

**Revision Note**

Data sheet

**Date**

22-11-12

**Signature**

ML



As part of the company policy of continued product improvement, specifications may change without notice. Our sales office will be pleased to help you with the latest information on this product range and the details of our full design and manufacturing service. All products are supplied to our standard conditions of sale unless otherwise agreed in writing.

**Phone : +44 (0)1255 862236**

**www.comuseurope.co.uk**

**Fax: +44 (0)1255 862014**