

# Signal Chain Power ADP150 Ultralow Noise, Low Dropout Linear Regulator

## DESCRIPTION

Demonstration circuit SCP-ADP150-EVALZ features the ADP150, an ultralow noise (9µV), low dropout, linear regulator that operates from 2.2V to 5.5V and provides up to 150mA of output current. ADP150AUJZ-3.3-R7 fixed voltage IC is installed on this board.

Like all boards in the Signal Chain Power series, this board is designed to be easily plugged into other SCP boards to form a complete signal chain power system, enabling fast evaluation of low power signal chains. To evaluate this board, some universal SCP hardware is required, namely:

- SCP-INPUT-EVALZ                    SCP-1X2BKOUT-EVALZ
- SCP-OUTPUT-EVALZ                SCP-1X5BKOUT-EVALZ
- SCP-FILTER-EVALZ                 SCP-5X1-EVALZ
- SCP-THRUBRD-EVALZ

To properly evaluate SCP series demo boards, you will need the SCP Configurator companion software. SCP Configurator can help you choose the right board and topology for your design.

Note that this Demo Manual does not cover details important to the operation and configuration regarding the [ADP150](#). Please refer to the [ADP150 datasheet](#) for a complete description of the part.

**Design files for this circuit board are available.**

All registered trademarks and trademarks are property of their respective owners.

**Table 1. Performance Summary**

| SYMBOL                | PARAMETER          | NOTES | MIN | TYP | MAX | UNITS |
|-----------------------|--------------------|-------|-----|-----|-----|-------|
| V <sub>IN(MAX)</sub>  | Max Input Voltage  |       |     |     | 6.5 | V     |
| V <sub>OUT(MAX)</sub> | Max Output Voltage |       |     |     | 3.3 | V     |
| I <sub>OUT(MAX)</sub> | Max Output Current |       |     |     | 150 | mA    |

## BOARD IMAGE

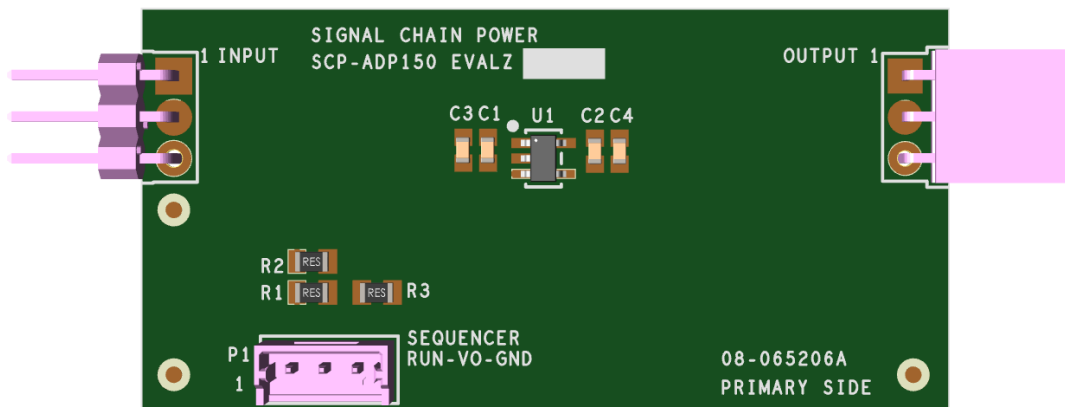

**Figure 1. Evaluation Board for ADP150 Ultralow Noise, Low Dropout Linear Regulator**

# DEMO MANUAL SCP-ADP150-EVALZ

## QUICK START PROCEDURE

Demonstration circuit SCP-ADP150-EVALZ is easy to set up to evaluate the performance of any SCP hardware configuration.

1. Connect the SCP-INPUT-EVALZ and SCP-OUTPUT-EVALZ boards to the SCP-ADP150-EVALZ (refer to Figure 2) and connect the input board to a voltage source,  $V_{SOURCE}$ . Connect the output board to a voltmeter or dynamic load. Slowly raise the input voltage until the SCP-ADP150-EVALZ powers up into regulation and sweep  $V_{SOURCE}$  through the desired range of operation.

NOTE: Make sure that the input voltage is always within specification. If using a dynamic load to measure output voltage, make sure the load is initially set to zero.

2. Check for proper output voltage. The output should be regulated to  $\sim 3.3V$ . Please check datasheet for details of regulation and accuracy specifications.
3. Once the proper output voltage is established, power off  $V_{SOURCE}$  and similarly test other boards in the SCP system until all elements have been individually verified prior to assembling into the final circuit configuration.

NOTE: When measuring the input or output voltage ripple, use the optional SMA connector locations available on the input, output,  $1 \times 5$ ,  $1 \times 2$ , and  $5 \times 1$  breakout boards. Avoid using the test point connections with long scope leads.

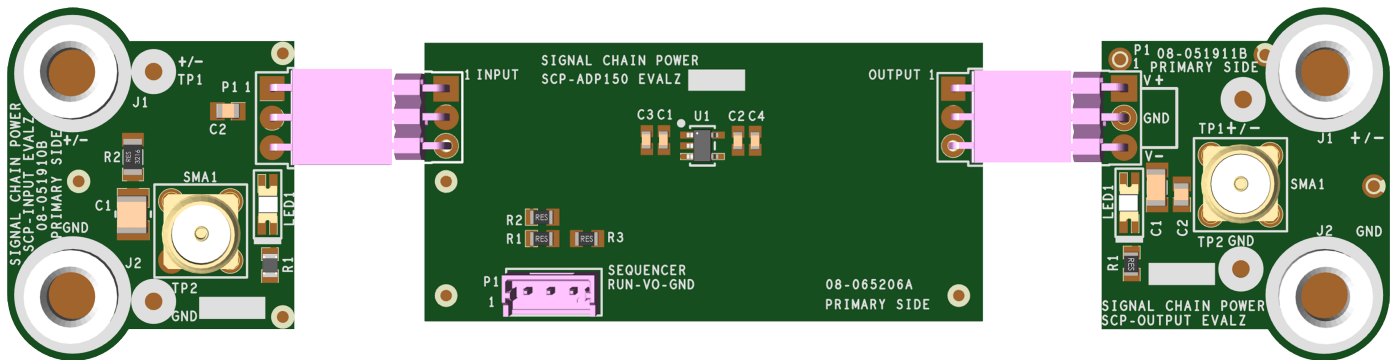

Figure 2. Proper Measurement Equipment Setup (Use SMA connectors for Measuring Input or Output Ripple)

## CONFIGURATION SETTINGS

Demonstration circuit SCP-ADP150-EVALZ features the ADP150, an ultralow noise (9 $\mu$ V), low dropout, linear regulator that operates from 2.2V to 5.5V and provides up to 150mA of output current. ADP150AUJZ-3.3-R7 fixed voltage IC is installed on this board.

### EN PIN CONFIGURATION

The EN pin is tied to the optional SCP Run/Sequence header P<sub>1</sub>. To create a harness for this function, use Molex part 0510650300 with crimp pin 50212-8000.

To use an active run signal, use a 1.00M $\Omega$  resistor for either pull-up or pull-down resistors R2 and R3, short R1 with 0 $\Omega$ , and use the drive signal from connector P1.

### OUTPUT VOLTAGE OPTIONS

The ADP150 is available in several fixed output voltage options, ranging from 1.8V to 3.3V. Please note that the demo board makes uses the TSOT package option when ordering alternative voltage options.

Table 2. ADP150 Part Selection by Output Voltage

| V <sub>OUT</sub> (V) | ADP150 MODEL       |
|----------------------|--------------------|
| 1.80                 | ADP150AUJZ-1.8-R7  |
| 2.00                 | ADP150AUJZ-2.0-R7  |
| 2.50                 | ADP150AUJZ-2.5-R7  |
| 2.65                 | ADP150AUJZ-2.65-R7 |
| 2.80                 | ADP150AUJZ-2.8-R7  |
| 3.00                 | ADP150AUJZ-3.0-R7  |
| 3.30                 | ADP150AUJZ-3.3-R7  |

# DEMO MANUAL SCP-ADP150-EVALZ

---

## PARTS LIST

| ITEM | QTY | REFERENCE | PART DESCRIPTION  | MANUFACTURER/PART NUMBER         |
|------|-----|-----------|---|----------------------------------|
| 1    | 1   | PCB       | PCB   | ANALOG DEVICES 08_065206a        |
| 2    | 2   | C1, C2    | CAP CER 1uF 10V 10% X7R 0603  | KEMET C0603C105K8RACTU           |
| 3    | 2   | C3, C4    | CAP MLCC 0603 (Note 1)  | N/A                              |
| 4    | 1   | INPUT     | CONN-PCB MALE HEADER 3POS 2.54MM PITCH R/A GOLD                         | SULLINS PBC03SBAN                |
| 5    | 1   | OUTPUT    | CONN FEMALE 3POS 2.54MM PITCH R/A GOLD                                  | SULLINS PPPC031LGBN-RC           |
| 6    | 1   | P1        | CONN-PCB 3POS HEADER WIRE TO BRD WAFER ASSY STRAIGHT 2MM PITCH (Note 1) | MOLEX 53253-0370                 |
| 7    | 2   | R1, R3    | RES THICK FILM 0805 (Note 1)  | N/A                              |
| 8    | 1   | R2        | RES SMD 1MEG Ohm 5% 1/8W 0805   | YAGEO RC0805JR-071ML             |
| 9    | 1   | U1        | IC-ADI ULTRALOW NOISE, CMOS LIN REG LDO 3.3VOUT                         | ANALOG DEVICES ADP150AUJZ-3.3-R7 |

**Note 1.** These items are not stuffed (DNI).

## SCHEMATIC DIAGRAM

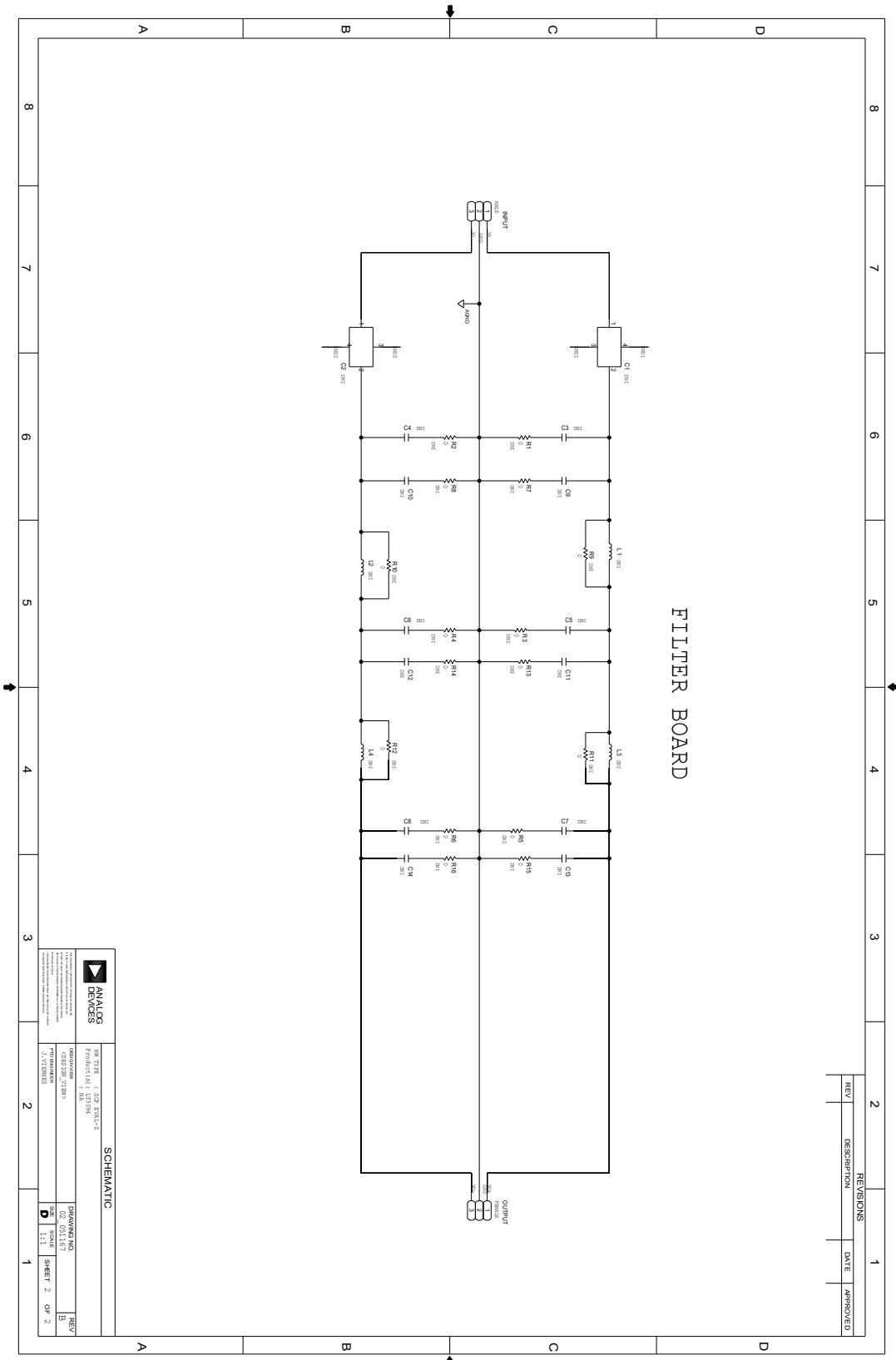

| REV | DESCRIPTION | DATE | APPROVED |
|-----|-------------|------|----------|
|     |             |      |          |

**ANALOG DEVICES**  
 Precision Integrated Circuits for Signal Conditioning, Data Conversion, and Interface Applications

**SCHEMATIC**

|        |      |          |
|--------|------|----------|
| REV. 1 | DATE | APPROVED |
|        |      |          |

DRAWING NO. 150-00000  
 SHEET 2 OF 2

# DEMO MANUAL SCP-ADP150-EVALZ

---



## ESD Caution

**ESD (electrostatic discharge) sensitive device.** Charged devices and circuit boards can discharge without detection. Although this product features patented or proprietary protection circuitry, damage may occur on devices subjected to high energy ESD. Therefore, proper ESD precautions should be taken to avoid performance degradation or loss of functionality.

## Legal Terms and Conditions

By using the evaluation board discussed herein (together with any tools, components documentation or support materials, the "Evaluation Board"), you are agreeing to be bound by the terms and conditions set forth below ("Agreement") unless you have purchased the Evaluation Board, in which case the Analog Devices Standard Terms and Conditions of Sale shall govern. Do not use the Evaluation Board until you have read and agreed to the Agreement. Your use of the Evaluation Board shall signify your acceptance of the Agreement. This Agreement is made by and between you ("Customer") and Analog Devices, Inc. ("ADI"), with its principal place of business at One Technology Way, Norwood, MA 02062, USA. Subject to the terms and conditions of the Agreement, ADI hereby grants to Customer a free, limited, personal, temporary, non-exclusive, non-sublicensable, non-transferable license to use the Evaluation Board FOR EVALUATION PURPOSES ONLY. Customer understands and agrees that the Evaluation Board is provided for the sole and exclusive purpose referenced above, and agrees not to use the Evaluation Board for any other purpose. Furthermore, the license granted is expressly made subject to the following additional limitations: Customer shall not (i) rent, lease, display, sell, transfer, assign, sublicense, or distribute the Evaluation Board; and (ii) permit any Third Party to access the Evaluation Board. As used herein, the term "Third Party" includes any entity other than ADI, Customer, their employees, affiliates and in-house consultants. The Evaluation Board is NOT sold to Customer; all rights not expressly granted herein, including ownership of the Evaluation Board, are reserved by ADI. CONFIDENTIALITY. This Agreement and the Evaluation Board shall all be considered the confidential and proprietary information of ADI. Customer may not disclose or transfer any portion of the Evaluation Board to any other party for any reason. Upon discontinuation of use of the Evaluation Board or termination of this Agreement, Customer agrees to promptly return the Evaluation Board to ADI. ADDITIONAL RESTRICTIONS. Customer may not disassemble, decompile or reverse engineer chips on the Evaluation Board. Customer shall inform ADI of any occurred damages or any modifications or alterations it makes to the Evaluation Board, including but not limited to soldering or any other activity that affects the material content of the Evaluation Board. Modifications to the Evaluation Board must comply with applicable law, including but not limited to the RoHS Directive. TERMINATION. ADI may terminate this Agreement at any time upon giving written notice to Customer. Customer agrees to return to ADI the Evaluation Board at that time. LIMITATION OF LIABILITY. THE EVALUATION BOARD PROVIDED HEREUNDER IS PROVIDED "AS IS" AND ADI MAKES NO WARRANTIES OR REPRESENTATIONS OF ANY KIND WITH RESPECT TO IT. ADI SPECIFICALLY DISCLAIMS ANY REPRESENTATIONS, ENDORSEMENTS, GUARANTEES, OR WARRANTIES, EXPRESS OR IMPLIED, RELATED TO THE EVALUATION BOARD INCLUDING, BUT NOT LIMITED TO, THE IMPLIED WARRANTY OF MERCHANTABILITY, TITLE, FITNESS FOR A PARTICULAR PURPOSE OR NON-INFRINGEMENT OF INTELLECTUAL PROPERTY RIGHTS. IN NO EVENT WILL ADI AND ITS LICENSORS BE LIABLE FOR ANY INCIDENTAL, SPECIAL, INDIRECT OR CONSEQUENTIAL DAMAGES RESULTING FROM CUSTOMER'S POSSESSION OR USE OF THE EVALUATION BOARD, INCLUDING BUT NOT LIMITED TO LOST PROFITS, DELAY COSTS, LABOR COSTS OR LOSS OF GOODWILL. ADI'S TOTAL LIABILITY FROM ANY AND ALL CAUSES SHALL BE LIMITED TO THE AMOUNT OF ONE HUNDRED US DOLLARS (\$100.00). EXPORT. Customer agrees that it will not directly or indirectly export the Evaluation Board to another country, and that it will comply with all applicable United States federal laws and regulations relating to exports. GOVERNING LAW. This Agreement shall be governed by and construed in accordance with the substantive laws of the Commonwealth of Massachusetts (excluding conflict of law rules). Any legal action regarding this Agreement will be heard in the state or federal courts having jurisdiction in Suffolk County, Massachusetts, and Customer hereby submits to the personal jurisdiction and venue of such courts. The United Nations Convention on Contracts for the International Sale of Goods shall not apply to this Agreement and is expressly disclaimed.