



# FocusLCDs.com

LCDs MADE SIMPLE®

Ph. 480-503-4295 | [NOPP@FocusLCD.com](mailto:NOPP@FocusLCD.com)

TFT | CHARACTER | UWVD | FSC | SEGMENT | CUSTOM | REPLACEMENT

## Character Display Module

### Part Number

C162NLGFGSW6WT3CXAH

### Overview

Character: 16x2 (49.7x25.3), FSTN,  
Gray background, White Edge LED,  
Bottom view, Wide temp, Transflective  
(positive), 3.3V LCD, 3.0V LED,  
Controller=ST7032, RoHS Compliant

## 1. Features

1. 5x8 dots with cursor
2. 16characters \*2lines display
3. I2C MPU interfaces
4. Built-in controller (ST7032i-oD)
5. Display Mode & Backlight Variations
6. ROHS Compliant

|                          |  |  |   |  |
|--------------------------|--|--|---|--|
| <b>LCD type</b>          | <input type="checkbox"/> TN                          |  |   |  |
|                          | <input type="checkbox"/> FSTN                        | <input checked="" type="checkbox"/> FSTN Negative    |   |  |
|                          | <input type="checkbox"/> STN Yellow Green            | <input type="checkbox"/> STN Gray                    | <input type="checkbox"/> STN Blue Negative        |  |
| <b>View direction</b>    | <input checked="" type="checkbox"/> 6 O'clock        |  | <input type="checkbox"/> 12 O'clock               |  |
| <b>Rear Polarizer</b>    | <input type="checkbox"/> Reflective                  |  | <input checked="" type="checkbox"/> Transflective | <input type="checkbox"/> Transmissive              |
| <b>Backlight Type</b>    | <input type="checkbox"/> LED Array                   |  | <input type="checkbox"/> EL                       | <input type="checkbox"/> Internal Power            |
|                          | <input checked="" type="checkbox"/> LED Edge         |  | <input type="checkbox"/> CCFL                     | <input checked="" type="checkbox"/> External Power |
| <b>Backlight Color</b>   | <input checked="" type="checkbox"/> White            | <input type="checkbox"/> Blue                        | <input type="checkbox"/> Amber                    | <input type="checkbox"/> Yellow-Green              |
| <b>Temperature Range</b> | <input type="checkbox"/> Normal                      |  | <input checked="" type="checkbox"/> Wide          | <input type="checkbox"/> Super Wide                |
| <b>DC to DC circuit</b>  | <input checked="" type="checkbox"/> Build-in         |  | <input type="checkbox"/> Not Build-in             |  |
| <b>Touch screen</b>      | <input type="checkbox"/> With                        |  | <input checked="" type="checkbox"/> Without       |  |
| <b>Font type</b>         | <input checked="" type="checkbox"/> English-Japanese | <input checked="" type="checkbox"/> English-European | <input type="checkbox"/> English-Russian          | <input type="checkbox"/> Other                     |

## 2. MECHANICAL SPECIFICATIONS

|                 |                               |
|-----------------|-------------------------------|
| Module size     | 49.7mm(L)*25.3mm(W)* 5.5mm(H) |
| Viewing area    | 45.7mm(L)*14.3mm(W)           |
| Character size  | 2.21mm(L)*4.68mm(W)           |
| Character pitch | 2.71mm(L)*6.64mm(W)           |
| Weight          | Approx.                       |

### 3. Outline dimension

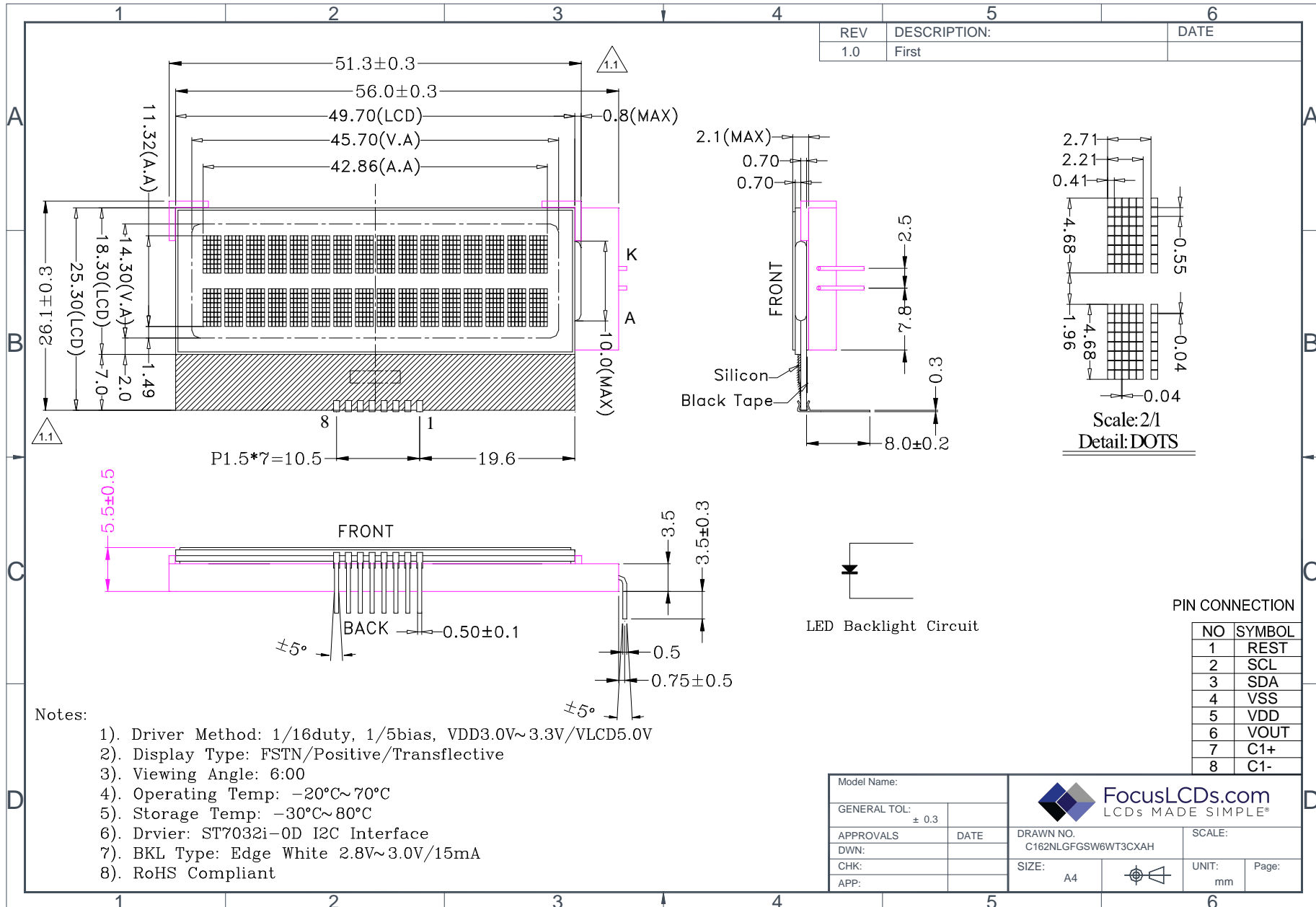

#### 4. Absolute maximum ratings

| Item                        | Symbol          | Standard |   |     | Unit |
|-----------------------------|-----------------|----------|---|-----|------|
| Power voltage               | $V_{DD}-V_{SS}$ | 0        | - | 6.0 | V    |
| Input voltage               | $V_{IN}$        | VSS      | - | VDD |      |
| Operating temperature range | $V_{OP}$        | -20      | - | +70 | °C   |
| Storage temperature range   | $V_{ST}$        | -30      | - | +80 |      |

#### 5. Block diagram

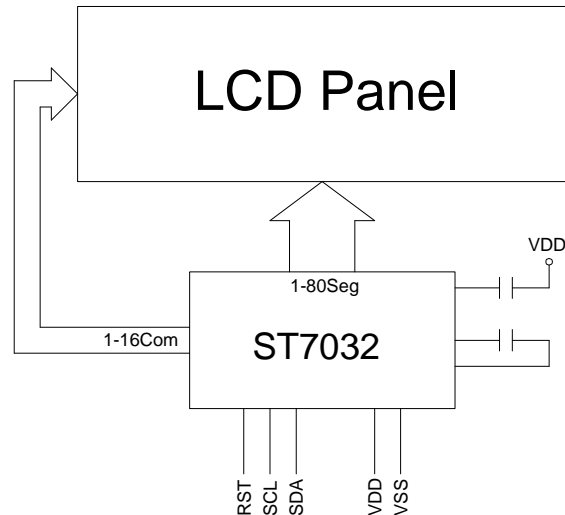

Capacitance 0.47uF~2.2uF

#### 6. Interface pin description

| Pin no. | Symbol    | External connection  | Function  |
|---------|-----------|----------------------|---|
| 1       | RST       | MPU                  | External reset PIN. Must be fixed to VDD low active.                |
| 2       | SCL       | MPU                  | Serial clock  |
| 3       | SDA       | MPU                  | Input data  |
| 4       | Vss       | Power supply         | Signal ground for LCM   |
| 5       | VDD       |                      | Power supply for logic for LCM                                      |
| 6       | $V_{OUT}$ |                      | DC/DC voltage converter   |
| 7       | C1+       |                      | For voltage booster circuit. External capacitor about 0.47uF~2.2Uf. |
| 8       | C1-       |                      |   |
| A       | LED+      | LED BKL power supply | Power supply for BKL  |
| K       | LED-      |                      | Power supply for BKL  |

## 7. Contrast adjust

### V0 voltage follower value calculation

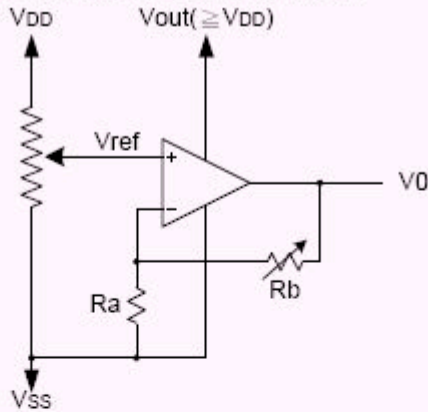

$$V0 = \left(1 + \frac{R_b}{R_a}\right) * V_{ref}$$

$$\text{While } V_{ref} = V_{DD} * \left(\frac{\alpha + 36}{100}\right)$$

| C5 | C4 | C3 | C2 | C1 | C0 | $\alpha$ |
|----|----|----|----|----|----|----------|
| 0  | 0  | 0  | 0  | 0  | 0  | 0        |
| 0  | 0  | 0  | 0  | 0  | 1  | 1        |
| 0  | 0  | 0  | 0  | 1  | 0  | 2        |
| .  |    |    |    |    |    | .        |
| .  |    |    |    |    |    | .        |
| 1  | 1  | 1  | 1  | 0  | 1  | 61       |
| 1  | 1  | 1  | 1  | 1  | 0  | 62       |
| 1  | 1  | 1  | 1  | 1  | 1  | 63       |

| Rab2 | Rab1 | Rab0 | 1+Rb/Ra |
|------|------|------|---------|
| 0    | 0    | 0    | 1       |
| 0    | 0    | 1    | 1.25    |
| 0    | 1    | 0    | 1.5     |
| 0    | 1    | 1    | 1.8     |
| 1    | 0    | 0    | 2       |
| 1    | 0    | 1    | 2.5     |
| 1    | 1    | 0    | 3       |
| 1    | 1    | 1    | 3.75    |

## 8. Optical characteristics

FSTN type display module

| Item                          | Symbol      | Condition      | Min.           | Typ. | Max. | Unit |     |
|-------------------------------|-------------|----------------|----------------|------|------|------|-----|
| Viewing angle<br>(12 O'clock) | Left--Right | $\theta$       | Ta=25°C        | -    | 60   | -    | deg |
|                               | Top--Bottom |                |                | -    | 80   | -    |     |
| Contrast ratio                | CR          | Ta=25°C        | 3              | 5    | -    | -    |     |
| Response time                 | Rise        |                | t <sub>r</sub> | -    | 150  | 250  | ms  |
|                               | Tall        | t <sub>f</sub> | -              | 200  | 300  |      |     |

## 9. Electrical characteristics

DC characteristics

| Parameter                | Symbol                          | Conditions                     | Min. | Typ. | Max.            | Unit |
|--------------------------|---------------------------------|--------------------------------|------|------|-----------------|------|
| Supply voltage for LCD   | V <sub>DD</sub> -V <sub>0</sub> | Ta =25°C                       | -    | 5.5  | -               | V    |
| Input voltage            | V <sub>DD</sub>                 |                                | 2.7  | 3.0  | 3.3             |      |
| Supply current           | I <sub>DD</sub>                 | Ta=25°C, V <sub>DD</sub> =3.0V | -    | 0.3  | 0.5             | mA   |
| Input leakage current    | I <sub>LKG</sub>                |                                | -    | -    | 1.0             | uA   |
| "H" level input voltage  | V <sub>IH</sub>                 |                                | 2.2  | -    | V <sub>DD</sub> | V    |
| "L" level input voltage  | V <sub>IL</sub>                 | Twice initial value or less    | 0    | -    | 0.6             |      |
| "H" level output voltage | V <sub>OH</sub>                 | LOH=-0.25mA                    | 2.4  | -    | -               |      |
| "L" level output voltage | V <sub>OL</sub>                 | LOH=1.6mA                      | -    | -    | 0.4             |      |
| Backlight supply voltage | V <sub>F</sub>                  |                                | -    | 3.0  | -               |      |
| Backlight supply current | I <sub>LED</sub>                | V <sub>F</sub> =3.0V           |      | 15   |                 | mA   |

## 10. Timing Characteristics

| Item   | Signal   | Symbol       | Condition | VDD=2.7 to 4.5V Rating |      | VDD=4.5 to 5.5V Rating |      | Units |
|--|----------|--------------|-----------|------------------------|------|------------------------|------|-------|
|  |          |              |           | Min.                   | Max. | Min.                   | Max. |       |
| SCL clock frequency                              | SCL      | $f_{SCLK}$   | —         | DC                     | 400  | DC                     | 400  | KHz   |
| SCL clock low period                             |          | $t_{LOW}$    |           | 1.3                    | —    | 1.3                    | —    | us    |
| SCL clock high period                            |          | $t_{HIGH}$   |           | 0.6                    | —    | 0.6                    | —    |       |
| Data set-up time                                 | SI       | $t_{SU,DAT}$ | —         | 180                    | —    | 100                    | —    | ns    |
| Data hold time                                   |          | $t_{HD,DAT}$ |           | 0                      | 0.9  | 0                      | 0.9  | us    |
| SCL,SDA rise time                                | SCL, SDA | $t_r$        | —         | $20+0.1C_b$            | 300  | $20+0.1C_b$            | 300  | ns    |
| SCL,SDA fall time                                |          | $t_f$        |           | $20+0.1C_b$            | 300  | $20+0.1C_b$            | 300  |       |
| Capacitive load represent by each bus line       |          | $C_b$        | —         | —                      | 400  | —                      | 400  | pf    |
| Setup time for a repeated START condition        | SI       | $t_{SU,STA}$ | —         | 0.6                    | —    | 0.6                    | —    | us    |
| Start condition hold time                        |          | $t_{HD,STA}$ | —         | 0.6                    | —    | 0.6                    | —    | us    |
| Setup time for STOP condition                    |          | $t_{SU,STO}$ | —         | 0.6                    | —    | 0.6                    | —    | us    |
| Bus free time between a Stop and START condition | SCL      | $t_{BUF}$    | —         | 1.3                    | —    | 1.3                    | —    | us    |

### Serial interface

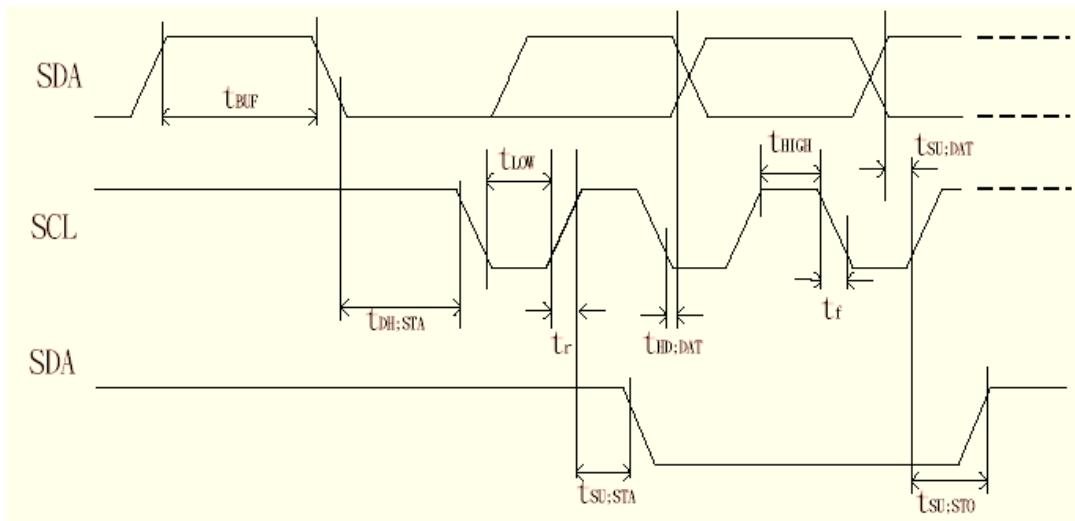

- **Display Data RAM (DDRAM)**

Display data RAM (DDRAM) stores display data represented in 8-bit character codes. Its extended capacity is 80 x 8 bits, or 80 characters. The area in display data RAM (DDRAM) that is not used for display can be used as general data RAM. See Figure 7 for the relationships between DDRAM addresses and positions on the liquid crystal display.

The DDRAM address ( $A_{DD}$ ) is set in the address counter (AC) as hexadecimal.

- **1-line display (N = 0) (Figure 8)**

When there are fewer than 80 display characters, the display begins at the head position. For example, if using only the ST7032, 16 characters are displayed. See Figure 8.

When the display shift operation is performed, the DDRAM address shifts. See Figure 9.

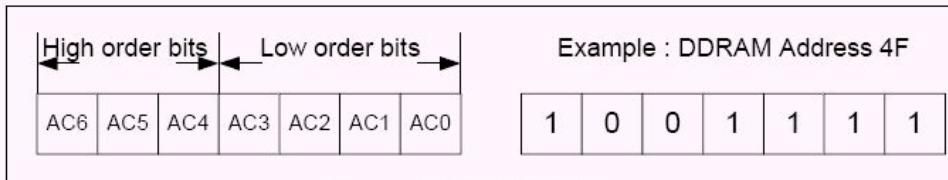

**Figure 7. DDRAM Address**

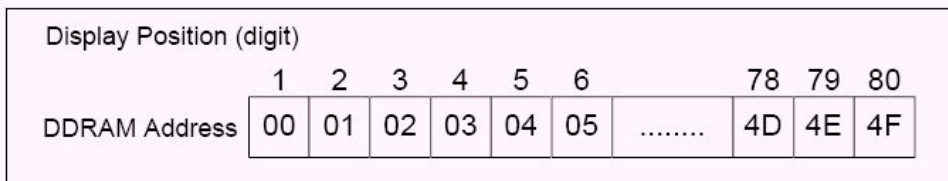

**Figure 8. 1-Line Display**

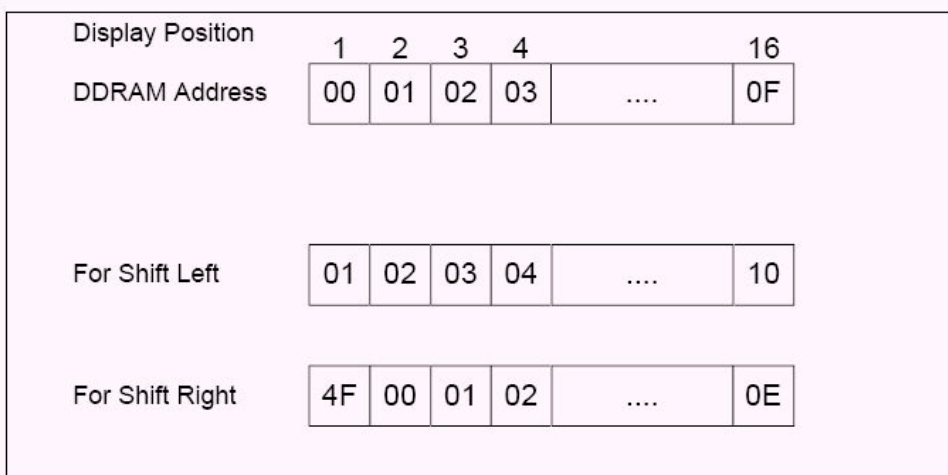

**Figure 9. 1-Line by 16-Character Display Example**



➤ **2-line display (N = 1) (Figure 10)**

Case 1: When the number of display characters is less than 40 . 2 lines, the two lines are displayed from the head. Note that the first line end address and the second line start address are not consecutive. See Figure 10.

| Display Position |    |    |    |    |    |    |       |    |    |    |
|------------------|----|----|----|----|----|----|-------|----|----|----|
|                  | 1  | 2  | 3  | 4  | 5  | 6  | ..... | 38 | 39 | 40 |
| DDRAM Address    | 00 | 01 | 02 | 03 | 04 | 05 | ..... | 25 | 26 | 27 |
| (hexadecimal)    | 40 | 41 | 42 | 43 | 44 | 45 | ..... | 65 | 66 | 67 |

**Figure 10. 2-Line Display**

Case 2: For a 16-character . 2-line display See Figure 11.

When display shift operation is performed, the DDRAM address shifts. See Figure 11.

|                  |    |    |    |    |    |    |    |    |    |    |    |    |    |    |    |    |
|------------------|----|----|----|----|----|----|----|----|----|----|----|----|----|----|----|----|
| Display Position | 1  | 2  | 3  | 4  | 5  | 6  | 7  | 8  | 9  | 10 | 11 | 12 | 13 | 14 | 15 | 16 |
| DDRAM Address    | 00 | 01 | 02 | 03 | 04 | 05 | 06 | 07 | 08 | 09 | 0A | 0B | 0C | 0D | 0E | 0F |
|                  | 40 | 41 | 42 | 43 | 44 | 45 | 46 | 47 | 48 | 49 | 4A | 4B | 4C | 4D | 4E | 4F |
| For Shift Left   | 01 | 02 | 03 | 04 | 05 | 06 | 07 | 08 | 09 | 0A | 0B | 0C | 0D | 0E | 0F | 10 |
|                  | 41 | 42 | 43 | 44 | 45 | 46 | 47 | 48 | 49 | 4A | 4B | 4C | 4D | 4E | 4F | 50 |
| For Shift Right  | 27 | 00 | 01 | 02 | 03 | 04 | 05 | 06 | 07 | 08 | 09 | 0A | 0B | 0C | 0D | 0E |
|                  | 67 | 40 | 41 | 42 | 43 | 44 | 45 | 46 | 47 | 48 | 49 | 4A | 4B | 4C | 4D | 4E |

**Figure 11. 2-Line by 16-Character Display Example**

**Hardware reset (RST)**

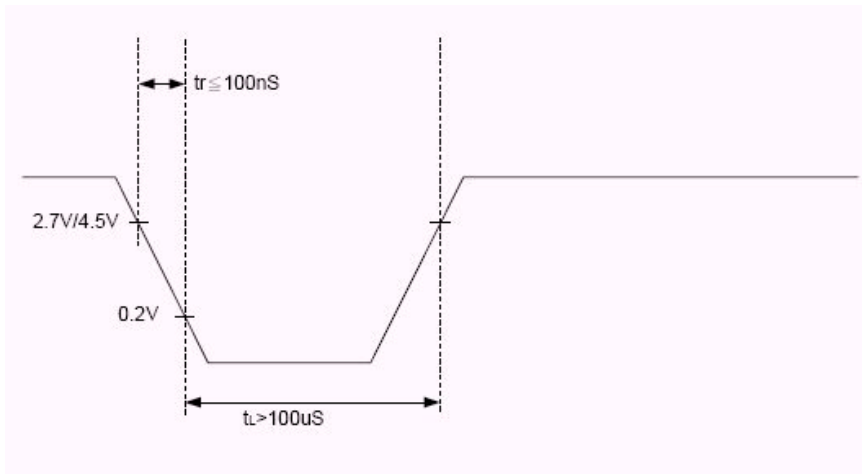



## 11. Instruction description

There are four categories of instructions that:

- Designate ST7032 functions, such as display format, data length, etc.
- Set internal RAM addresses
- Perform data transfer with internal RAM
- Others

### ➤ instruction table at “Normal mode”

(When “EXT” option pin connect to VDD, the instruction set follow below table)

| Instruction                | Instruction Code |     |     |     |     |     |     |     |     |     | Description  | Instruction Execution Time |            |            |
|----------------------------|------------------|-----|-----|-----|-----|-----|-----|-----|-----|-----|--|----------------------------|------------|------------|
|                            | RS               | R/W | DB7 | DB6 | DB5 | DB4 | DB3 | DB2 | DB1 | DB0 |  | OSC=380KHz                 | OSC=540kHz | OSC=700KHz |
| Clear Display              | 0                | 0   | 0   | 0   | 0   | 0   | 0   | 0   | 0   | 1   | Write "20H" to DDRAM. and set DDRAM address to "00H" from AC   | 1.08 ms                    | 0.76 ms    | 0.59 ms    |
| Return Home                | 0                | 0   | 0   | 0   | 0   | 0   | 0   | 0   | 1   | x   | Set DDRAM address to "00H" from AC and return cursor to its original position if shifted. The contents of DDRAM are not changed. | 1.08 ms                    | 0.76 ms    | 0.59 ms    |
| Entry Mode Set             | 0                | 0   | 0   | 0   | 0   | 0   | 0   | 1   | I/D | S   | Sets cursor move direction and specifies display shift. These operations are performed during data write and read.               | 26.3 us                    | 18.5 us    | 14.3 us    |
| Display ON/OFF             | 0                | 0   | 0   | 0   | 0   | 0   | 1   | D   | C   | B   | D=1:entire display on<br>C=1:cursor on<br>B=1:cursor position on   | 26.3 us                    | 18.5 us    | 14.3 us    |
| Cursor or Display Shift    | 0                | 0   | 0   | 0   | 0   | 1   | S/C | R/L | x   | x   | S/C and R/L:<br>Set cursor moving and display shift control bit, and the direction, without changing DDRAM data.                 | 26.3 us                    | 18.5 us    | 14.3 us    |
| Function Set               | 0                | 0   | 0   | 0   | 1   | DL  | N   | x   | x   | x   | DL: interface data is 8/4 bits<br>N: number of line is 2/1   | 26.3 us                    | 18.5 us    | 14.3 us    |
| Set CGRAM                  | 0                | 0   | 0   | 1   | AC5 | AC4 | AC3 | AC2 | AC1 | AC0 | Set CGRAM address in address counter   | 26.3 us                    | 18.5 us    | 14.3 us    |
| Set DDRAM address          | 0                | 0   | 1   | AC6 | AC5 | AC4 | AC3 | AC2 | AC1 | AC0 | Set DDRAM address in address counter   | 26.3 us                    | 18.5 us    | 14.3 us    |
| Read Busy flag and address | 0                | 1   | BF  | AC6 | AC5 | AC4 | AC3 | AC2 | AC1 | AC0 | Whether during internal operation or not can be known by reading BF. The contents of address counter can also be read.           | 0                          | 0          | 0          |
| Write data to RAM          | 1                | 0   | D7  | D6  | D5  | D4  | D3  | D2  | D1  | D0  | Write data into internal RAM (DDRAM/CGRAM)   | 26.3 us                    | 18.5 us    | 14.3 us    |
| Read data from RAM         | 1                | 1   | D7  | D6  | D5  | D4  | D3  | D2  | D1  | D0  | Read data from internal RAM (DDRAM/CGRAM)  | 26.3 us                    | 18.5 us    | 14.3 us    |

Note:

Be sure the ST7032 is not in the busy state (BF = 0) before sending an instruction from the MPU to the ST7032. If an instruction is sent without checking the busy flag, the time between the first instruction and next instruction will take much longer than the instruction time itself. Refer to Instruction Table for the list of each instruction execution time.

➤ **instruction table at "Extension mode"**

(when "EXT" option pin connect to VSS, the instruction set follow below table)

| Instruction                | Instruction Code |     |     |     |     |     |     |     |     |     | Description | Instruction Execution Time   |            |            |         |
|----------------------------|------------------|-----|-----|-----|-----|-----|-----|-----|-----|-----|-------------|--|------------|------------|---------|
|                            | RS               | R/W | DB7 | DB6 | DB5 | DB4 | DB3 | DB2 | DB1 | DB0 |             | OSC=380KHz   | OSC=540kHz | OSC=700KHz |         |
| Clear Display              | 0                | 0   | 0   | 0   | 0   | 0   | 0   | 0   | 0   | 0   | 1           | Write "20H" to DDRAM. and set DDRAM address to "00H" from AC   | 1.08 ms    | 0.76 ms    | 0.59 ms |
| Return Home                | 0                | 0   | 0   | 0   | 0   | 0   | 0   | 0   | 0   | 1   | x           | Set DDRAM address to "00H" from AC and return cursor to its original position if shifted. The contents of DDRAM are not changed. | 1.08 ms    | 0.76 ms    | 0.59 ms |
| Entry Mode Set             | 0                | 0   | 0   | 0   | 0   | 0   | 0   | 1   | I/D | S   |             | Sets cursor move direction and specifies display shift. These operations are performed during data write and read.               | 26.3 us    | 18.5 us    | 14.3 us |
| Display ON/OFF             | 0                | 0   | 0   | 0   | 0   | 0   | 1   | D   | C   | B   |             | D=1:entire display on<br>C=1:cursor on<br>B=1:cursor position on   | 26.3 us    | 18.5 us    | 14.3 us |
| Function Set               | 0                | 0   | 0   | 0   | 1   | DL  | N   | DH  | *0  | IS  |             | DL: interface data is 8/4 bits<br>N: number of line is 2/1<br>DH: double height font<br>IS: instruction table select             | 26.3 us    | 18.5 us    | 14.3 us |
| Set DDRAM address          | 0                | 0   | 1   | AC6 | AC5 | AC4 | AC3 | AC2 | AC1 | AC0 |             | Set DDRAM address in address counter   | 26.3 us    | 18.5 us    | 14.3 us |
| Read Busy flag and address | 0                | 1   | BF  | AC6 | AC5 | AC4 | AC3 | AC2 | AC1 | AC0 |             | Whether during internal operation or not can be known by reading BF. The contents of address counter can also be read.           | 0          | 0          | 0       |
| Write data to RAM          | 1                | 0   | D7  | D6  | D5  | D4  | D3  | D2  | D1  | D0  |             | Write data into internal RAM (DDRAM/CGRAM/ICONRAM)   | 26.3 us    | 18.5 us    | 14.3 us |
| Read data from RAM         | 1                | 1   | D7  | D6  | D5  | D4  | D3  | D2  | D1  | D0  |             | Read data from internal RAM (DDRAM/CGRAM/ICONRAM)  | 26.3 us    | 18.5 us    | 14.3 us |

Note \*: this bit is for test command , and must always set to "0"

**Instruction table 0(IS=0)**

|                         |   |   |   |   |     |     |     |     |     |     |  |  |         |         |         |
|-------------------------|---|---|---|---|-----|-----|-----|-----|-----|-----|--|--|---------|---------|---------|
| Cursor or Display Shift | 0 | 0 | 0 | 0 | 0   | 1   | S/C | R/L | x   | x   |  | S/C and R/L:<br>Set cursor moving and display shift control bit, and the direction, without changing DDRAM data. | 26.3 us | 18.5 us | 14.3 us |
| Set CGRAM               | 0 | 0 | 0 | 1 | AC5 | AC4 | AC3 | AC2 | AC1 | AC0 |  | Set CGRAM address in address counter   | 26.3 us | 18.5 us | 14.3 us |

**Instruction table 1(IS=1)**

|                                 |   |   |   |   |   |   |     |      |      |      |  |  |         |         |         |
|---------------------------------|---|---|---|---|---|---|-----|------|------|------|--|--|---------|---------|---------|
| Internal OSC frequency          | 0 | 0 | 0 | 0 | 0 | 1 | BS  | F2   | F1   | F0   |  | BS=1:1/4 bias<br>BS=0:1/5 bias<br>F2~0: adjust internal OSC frequency for FR frequency.                        | 26.3 us | 18.5 us | 14.3 us |
| Set ICON address                | 0 | 0 | 0 | 1 | 0 | 0 | AC3 | AC2  | AC1  | AC0  |  | Set ICON address in address counter.   | 26.3 us | 18.5 us | 14.3 us |
| Power/ICON control/Contrast set | 0 | 0 | 0 | 1 | 0 | 1 | Ion | Bon  | C5   | C4   |  | Ion: ICON display on/off<br>Bon: set booster circuit on/off<br>C5,C4: Contrast set for internal follower mode. | 26.3 us | 18.5 us | 14.3 us |
| Follower control                | 0 | 0 | 0 | 1 | 1 | 0 | Fon | Rab2 | Rab1 | Rab0 |  | Fon: set follower circuit on/off<br>Rab2~0: select follower amplified ratio.                                   | 26.3 us | 18.5 us | 14.3 us |
| Contrast set                    | 0 | 0 | 0 | 1 | 1 | 1 | C3  | C2   | C1   | C0   |  | Contrast set for internal follower mode.   | 26.3 us | 18.5 us | 14.3 us |



### 13. Standard character pattern

| b7-b4<br>b3-b0 | 0000 | 0001 | 0010 | 0011 | 0100 | 0101 | 0110 | 0111 | 1000 | 1001 | 1010 | 1011 | 1100 | 1101 | 1110 | 1111 |
|----------------|------|------|------|------|------|------|------|------|------|------|------|------|------|------|------|------|
| 0000           | f    | A    |      | 0    | a    | P    | ^    | P    | G    | E    |      | -    | o    | E    | a    |      |
| 0001           | J    | +    | !    | 1    | A    | 0    | a    | A    | 0    | a    | .    | 7    | 7    | 4    | a    |      |
| 0010           | o    | S    | "    | 2    | B    | R    | b    | r    | a    | E    | T    | 4    | U    | X    | a    | *    |
| 0011           | P    | 7    | #    | 3    | C    | S    | c    | S    | a    | a    | J    | o    | T    | E    | a    | *    |
| 0100           | 4    | P    | *    | 4    | D    | T    | d    | t    | a    | a    | .    | I    | T    | P    | a    | *    |
| 0101           | ↑    | Δ    | X    | 5    | E    | U    | e    | u    | a    | a    | *    | 7    | 7    | 1    | E    | U    |
| 0110           | ↓    | θ    | θ    | 6    | F    | V    | f    | v    | a    | a    | 7    | 0    | 2    | 3    | *    | U    |
| 0111           | →    | Δ    | '    | 7    | G    | W    | g    | w    | S    | U    | 7    | *    | X    | 7    | R    | X    |
| 1000           | ←    | E    | C    | 8    | H    | X    | h    | X    | a    | 9    | 4    | o    | *    | U    | *    | *    |
| 1001           | Π    | Π    | )    | 9    | I    | Y    | i    | y    | a    | 0    | a    | 7    | 7    | U    | i    | X    |
| 1010           | 7    | Σ    | *    | *    | J    | Z    | j    | z    | a    | 0    | a    | 0    | n    | U    | a    | X    |
| 1011           | L    | P    | +    | *    | K    | E    | k    | ε    | i    | A    | *    | 7    | E    | 0    | a    | *    |
| 1100           | U    | θ    | .    | <    | L    | *    | l    | l    | i    | A    | *    | 7    | 7    | 7    | a    | *    |
| 1101           | .    | U    | -    | =    | N    | U    | n    | U    | i    | a    | a    | X    | a    | U    | a    | *    |
| 1110           | 0    | 0    | .    | >    | N    | ^    | n    | *    | a    | 0    | a    | E    | 0    | *    | 0    | T    |
| 1111           | 0    | o    | /    | ?    | 0    | L    | o    | ε    | a    | a    | o    | U    | 7    | P    | *    |      |

## 14. QUALITY SPECIFICATIONS

### 14.1 Standard of the product appearance test

Manner of appearance test: The inspection should be performed in using 20W x 2 fluorescent lamps. Distance between LCM and fluorescent lamps should be 100 cm or more. Distance between LCM and inspector eyes should be 30 cm or more.

Viewing direction for inspection is 45° from vertical against LCM.

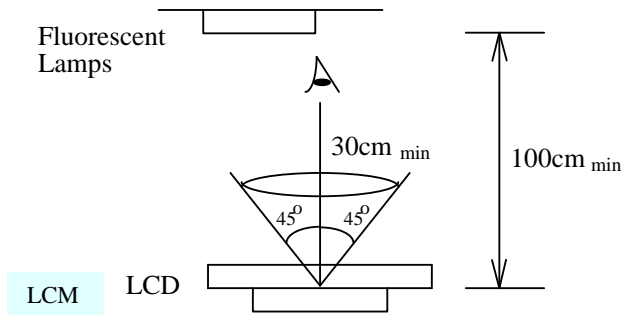

Definition of zone:

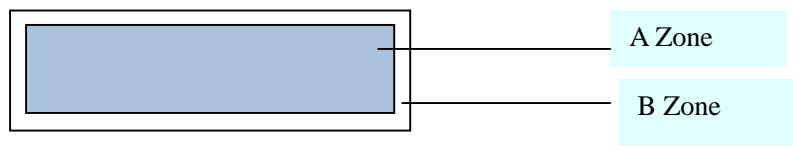

A Zone: Active display area (minimum viewing area).

B Zone: Non-active display area (outside viewing area).

## 14.2 Specification of quality assurance

AQL inspection standard

Sampling method: MIL-STD-105E, Level II, single sampling

Defect classification **(Note: \* is not including)**

| Classify                   | Item          |                              | Note | AQL  |
|----------------------------|---------------|------------------------------|------|------|
| Major                      | Display state | Short or open circuit        | 1    | 0.65 |
|                            |               | LC leakage                   |      |      |
|                            |               | Flickering                   |      |      |
|                            |               | No display                   |      |      |
|                            |               | Wrong viewing direction      |      |      |
|                            |               | Contrast defect (dim, ghost) | 2    |      |
|                            |               | Back-light                   | 1,8  |      |
|                            | Non-display   | Flat cable or pin reverse    | 10   |      |
| Wrong or missing component |               | 11                           |      |      |
| Minor                      | Display state | Background color deviation   | 2    | 1.0  |
|                            |               | Black spot and dust          | 3    |      |
|                            |               | Line defect, Scratch         | 4    |      |
|                            |               | Rainbow                      | 5    |      |
|                            |               | Chip                         | 6    |      |
|                            |               | Pin hole                     | 7    |      |
|                            | Polarizer     | Protruded                    | 12   |      |
|                            |               | Bubble and foreign material  | 3    |      |
|                            | Soldering     | Poor connection              | 9    |      |
|                            | Wire          | Poor connection              | 10   |      |
|                            | TAB           | Position, Bonding strength   | 13   |      |

**Note on defect classification**

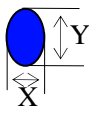
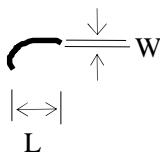
| No.                     | Item   | Criterion  |            |                 |                  |           |                         |   |                         |                |                         |              |               |   |              |               |              |           |   |     |            |                         |
|-------------------------|--|--|------------|-----------------|------------------|-----------|-------------------------|---|-------------------------|----------------|-------------------------|--------------|---------------|---|--------------|---------------|--------------|-----------|---|-----|------------|-------------------------|
| 1                       | Short or open circuit  | Not allow  |            |                 |                  |           |                         |   |                         |                |                         |              |               |   |              |               |              |           |   |     |            |                         |
|                         | LC leakage   |  |            |                 |                  |           |                         |   |                         |                |                         |              |               |   |              |               |              |           |   |     |            |                         |
|                         | Flickering   |  |            |                 |                  |           |                         |   |                         |                |                         |              |               |   |              |               |              |           |   |     |            |                         |
|                         | No display   |  |            |                 |                  |           |                         |   |                         |                |                         |              |               |   |              |               |              |           |   |     |            |                         |
|                         | Wrong viewing direction  |  |            |                 |                  |           |                         |   |                         |                |                         |              |               |   |              |               |              |           |   |     |            |                         |
|                         | Wrong Back-light   |  |            |                 |                  |           |                         |   |                         |                |                         |              |               |   |              |               |              |           |   |     |            |                         |
| 2                       | Contrast defect  | Refer to approval sample   |            |                 |                  |           |                         |   |                         |                |                         |              |               |   |              |               |              |           |   |     |            |                         |
|                         | Background color deviation   |  |            |                 |                  |           |                         |   |                         |                |                         |              |               |   |              |               |              |           |   |     |            |                         |
| 3                       | Point defect,<br>Black spot, dust<br>(including Polarizer)<br><br>$\phi = (X+Y)/2$ |  <table border="1" data-bbox="861 869 1300 1164"> <thead> <tr> <th>Point Size</th> <th>Acceptable Qty.</th> </tr> </thead> <tbody> <tr> <td><math>\phi \leq 0.10</math></td> <td>Disregard</td> </tr> <tr> <td><math>0.10 &lt; \phi \leq 0.20</math></td> <td>3</td> </tr> <tr> <td><math>0.20 &lt; \phi \leq 0.25</math></td> <td>2</td> </tr> <tr> <td><math>0.25 &lt; \phi \leq 0.30</math></td> <td>1</td> </tr> <tr> <td><math>\phi &gt; 0.30</math></td> <td>0</td> </tr> </tbody> </table> <p style="text-align: right;">Unit: mm</p>  | Point Size | Acceptable Qty. | $\phi \leq 0.10$ | Disregard | $0.10 < \phi \leq 0.20$ | 3 | $0.20 < \phi \leq 0.25$ | 2              | $0.25 < \phi \leq 0.30$ | 1            | $\phi > 0.30$ | 0 |              |               |              |           |   |     |            |                         |
| Point Size              | Acceptable Qty.  |  |            |                 |                  |           |                         |   |                         |                |                         |              |               |   |              |               |              |           |   |     |            |                         |
| $\phi \leq 0.10$        | Disregard  |  |            |                 |                  |           |                         |   |                         |                |                         |              |               |   |              |               |              |           |   |     |            |                         |
| $0.10 < \phi \leq 0.20$ | 3  |  |            |                 |                  |           |                         |   |                         |                |                         |              |               |   |              |               |              |           |   |     |            |                         |
| $0.20 < \phi \leq 0.25$ | 2  |  |            |                 |                  |           |                         |   |                         |                |                         |              |               |   |              |               |              |           |   |     |            |                         |
| $0.25 < \phi \leq 0.30$ | 1  |  |            |                 |                  |           |                         |   |                         |                |                         |              |               |   |              |               |              |           |   |     |            |                         |
| $\phi > 0.30$           | 0  |  |            |                 |                  |           |                         |   |                         |                |                         |              |               |   |              |               |              |           |   |     |            |                         |
| 4                       | Line defect,<br>Scratch  |  <table border="1" data-bbox="790 1299 1340 1556"> <thead> <tr> <th colspan="2">Line</th> <th>Acceptable Qty.</th> </tr> <tr> <th>L</th> <th>W</th> <th></th> </tr> </thead> <tbody> <tr> <td>---</td> <td><math>0.015 \geq W</math></td> <td>Disregard</td> </tr> <tr> <td><math>3.0 \geq L</math></td> <td><math>0.03 \geq W</math></td> <td rowspan="2">2</td> </tr> <tr> <td><math>2.0 \geq L</math></td> <td><math>0.05 \geq W</math></td> </tr> <tr> <td><math>1.0 \geq L</math></td> <td><math>0.1 &gt; W</math></td> <td>1</td> </tr> <tr> <td>---</td> <td><math>0.05 &lt; W</math></td> <td>Applied as point defect</td> </tr> </tbody> </table> <p style="text-align: right;">Unit: mm</p> | Line       |                 | Acceptable Qty.  | L         | W                       |   | ---                     | $0.015 \geq W$ | Disregard               | $3.0 \geq L$ | $0.03 \geq W$ | 2 | $2.0 \geq L$ | $0.05 \geq W$ | $1.0 \geq L$ | $0.1 > W$ | 1 | --- | $0.05 < W$ | Applied as point defect |
| Line                    |  | Acceptable Qty.  |            |                 |                  |           |                         |   |                         |                |                         |              |               |   |              |               |              |           |   |     |            |                         |
| L                       | W  |  |            |                 |                  |           |                         |   |                         |                |                         |              |               |   |              |               |              |           |   |     |            |                         |
| ---                     | $0.015 \geq W$   | Disregard  |            |                 |                  |           |                         |   |                         |                |                         |              |               |   |              |               |              |           |   |     |            |                         |
| $3.0 \geq L$            | $0.03 \geq W$  | 2  |            |                 |                  |           |                         |   |                         |                |                         |              |               |   |              |               |              |           |   |     |            |                         |
| $2.0 \geq L$            | $0.05 \geq W$  |  |            |                 |                  |           |                         |   |                         |                |                         |              |               |   |              |               |              |           |   |     |            |                         |
| $1.0 \geq L$            | $0.1 > W$  | 1  |            |                 |                  |           |                         |   |                         |                |                         |              |               |   |              |               |              |           |   |     |            |                         |
| ---                     | $0.05 < W$   | Applied as point defect  |            |                 |                  |           |                         |   |                         |                |                         |              |               |   |              |               |              |           |   |     |            |                         |
| 5                       | Rainbow  | Not more than two color changes across the viewing area.   |            |                 |                  |           |                         |   |                         |                |                         |              |               |   |              |               |              |           |   |     |            |                         |

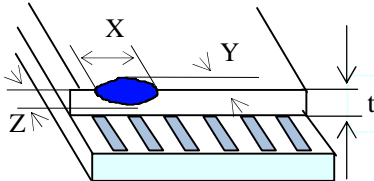
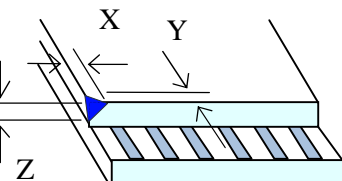
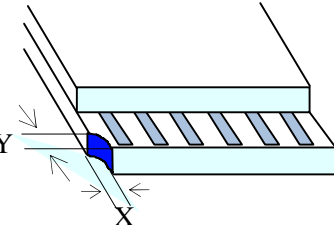
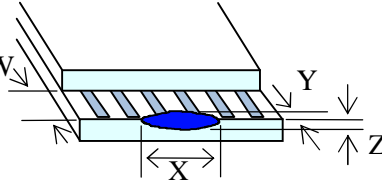
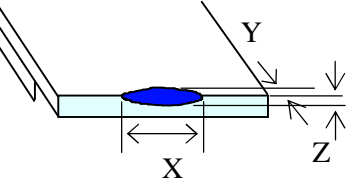
| No                     | Item   | Criterion   |   |   |   |          |       |            |   |   |   |          |       |          |   |   |   |          |          |          |                        |  |  |   |   |   |           |            |          |   |   |   |          |          |            |
|------------------------|--|---|---|---|---|----------|-------|------------|---|---|---|----------|-------|----------|---|---|---|----------|----------|----------|------------------------|--|--|---|---|---|-----------|------------|----------|---|---|---|----------|----------|------------|
| 6                      | <p>Chip</p> <p>Remark:<br/>           X: Length direction<br/>           Y: Short direction<br/>           Z: Thickness direction<br/>           t: Glass thickness<br/>           W: Terminal Width</p> |  <p>Acceptable criterion</p> <table border="1" data-bbox="933 358 1324 436"> <thead> <tr> <th>X</th> <th>Y</th> <th>Z</th> </tr> </thead> <tbody> <tr> <td><math>\leq 2</math></td> <td>0.5mm</td> <td><math>\leq t/2</math></td> </tr> </tbody> </table><br> <p>Acceptable criterion</p> <table border="1" data-bbox="925 672 1324 750"> <thead> <tr> <th>X</th> <th>Y</th> <th>Z</th> </tr> </thead> <tbody> <tr> <td><math>\leq 2</math></td> <td>0.5mm</td> <td><math>\leq t</math></td> </tr> </tbody> </table><br> <p>Acceptable criterion</p> <table border="1" data-bbox="933 963 1324 1075"> <thead> <tr> <th>X</th> <th>Y</th> <th>Z</th> </tr> </thead> <tbody> <tr> <td><math>\leq 3</math></td> <td><math>\leq 2</math></td> <td><math>\leq t</math></td> </tr> <tr> <td colspan="2">shall not reach to ITO</td> <td></td> </tr> </tbody> </table><br> <p>Acceptable criterion</p> <table border="1" data-bbox="925 1344 1324 1422"> <thead> <tr> <th>X</th> <th>Y</th> <th>Z</th> </tr> </thead> <tbody> <tr> <td>Disregard</td> <td><math>\leq 0.2</math></td> <td><math>\leq t</math></td> </tr> </tbody> </table><br> <p>Acceptable criterion</p> <table border="1" data-bbox="925 1624 1292 1702"> <thead> <tr> <th>X</th> <th>Y</th> <th>Z</th> </tr> </thead> <tbody> <tr> <td><math>\leq 5</math></td> <td><math>\leq 2</math></td> <td><math>\leq t/3</math></td> </tr> </tbody> </table> | X | Y | Z | $\leq 2$ | 0.5mm | $\leq t/2$ | X | Y | Z | $\leq 2$ | 0.5mm | $\leq t$ | X | Y | Z | $\leq 3$ | $\leq 2$ | $\leq t$ | shall not reach to ITO |  |  | X | Y | Z | Disregard | $\leq 0.2$ | $\leq t$ | X | Y | Z | $\leq 5$ | $\leq 2$ | $\leq t/3$ |
| X                      | Y  | Z   |   |   |   |          |       |            |   |   |   |          |       |          |   |   |   |          |          |          |                        |  |  |   |   |   |           |            |          |   |   |   |          |          |            |
| $\leq 2$               | 0.5mm  | $\leq t/2$  |   |   |   |          |       |            |   |   |   |          |       |          |   |   |   |          |          |          |                        |  |  |   |   |   |           |            |          |   |   |   |          |          |            |
| X                      | Y  | Z   |   |   |   |          |       |            |   |   |   |          |       |          |   |   |   |          |          |          |                        |  |  |   |   |   |           |            |          |   |   |   |          |          |            |
| $\leq 2$               | 0.5mm  | $\leq t$  |   |   |   |          |       |            |   |   |   |          |       |          |   |   |   |          |          |          |                        |  |  |   |   |   |           |            |          |   |   |   |          |          |            |
| X                      | Y  | Z   |   |   |   |          |       |            |   |   |   |          |       |          |   |   |   |          |          |          |                        |  |  |   |   |   |           |            |          |   |   |   |          |          |            |
| $\leq 3$               | $\leq 2$   | $\leq t$  |   |   |   |          |       |            |   |   |   |          |       |          |   |   |   |          |          |          |                        |  |  |   |   |   |           |            |          |   |   |   |          |          |            |
| shall not reach to ITO |  |   |   |   |   |          |       |            |   |   |   |          |       |          |   |   |   |          |          |          |                        |  |  |   |   |   |           |            |          |   |   |   |          |          |            |
| X                      | Y  | Z   |   |   |   |          |       |            |   |   |   |          |       |          |   |   |   |          |          |          |                        |  |  |   |   |   |           |            |          |   |   |   |          |          |            |
| Disregard              | $\leq 0.2$   | $\leq t$  |   |   |   |          |       |            |   |   |   |          |       |          |   |   |   |          |          |          |                        |  |  |   |   |   |           |            |          |   |   |   |          |          |            |
| X                      | Y  | Z   |   |   |   |          |       |            |   |   |   |          |       |          |   |   |   |          |          |          |                        |  |  |   |   |   |           |            |          |   |   |   |          |          |            |
| $\leq 5$               | $\leq 2$   | $\leq t/3$  |   |   |   |          |       |            |   |   |   |          |       |          |   |   |   |          |          |          |                        |  |  |   |   |   |           |            |          |   |   |   |          |          |            |

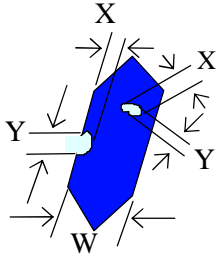
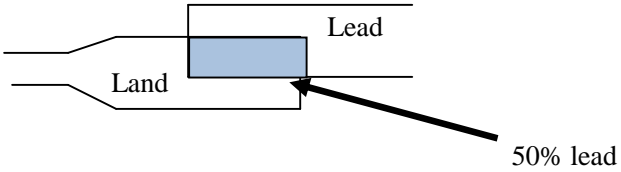

| No.                     | Item  | Criterion  |            |                |                  |           |                         |   |               |   |
|-------------------------|---|--|------------|----------------|------------------|-----------|-------------------------|---|---------------|---|
| 7                       | Segment pattern<br>$W = \text{Segment width}$<br>$\phi = (X+Y)/2$ | (1) Pin hole<br>$\phi < 0.10\text{mm}$ is acceptable.<br> <table border="1" data-bbox="853 537 1316 712"> <thead> <tr> <th>Point Size</th> <th>Acceptable Qty</th> </tr> </thead> <tbody> <tr> <td><math>\phi \leq 1/4W</math></td> <td>Disregard</td> </tr> <tr> <td><math>1/4W &lt; \phi \leq 1/2W</math></td> <td>1</td> </tr> <tr> <td><math>\phi &gt; 1/2W</math></td> <td>0</td> </tr> </tbody> </table> Unit: mm | Point Size | Acceptable Qty | $\phi \leq 1/4W$ | Disregard | $1/4W < \phi \leq 1/2W$ | 1 | $\phi > 1/2W$ | 0 |
| Point Size              | Acceptable Qty  |  |            |                |                  |           |                         |   |               |   |
| $\phi \leq 1/4W$        | Disregard   |  |            |                |                  |           |                         |   |               |   |
| $1/4W < \phi \leq 1/2W$ | 1   |  |            |                |                  |           |                         |   |               |   |
| $\phi > 1/2W$           | 0   |  |            |                |                  |           |                         |   |               |   |
| 8                       | Back-light  | (1) The color of backlight should correspond its specification.<br>(2) Not allow flickering  |            |                |                  |           |                         |   |               |   |
| 9                       | Soldering   | (1) Not allow heavy dirty and solder ball on PCB.<br>(The size of dirty refer to point and dust defect)<br>(2) Over 50% of lead should be soldered on Land.<br>  |            |                |                  |           |                         |   |               |   |
| 10                      | Wire  | (1) Copper wire should not be rusted<br>(2) Not allow crack on copper wire connection.<br>(3) Not allow reversing the position of the flat cable.<br>(4) Not allow exposed copper wire inside the flat cable.  |            |                |                  |           |                         |   |               |   |
| 11*                     | PCB   | (1) Not allow screw rust or damage.<br>(2) Not allow missing or wrong putting of component.  |            |                |                  |           |                         |   |               |   |

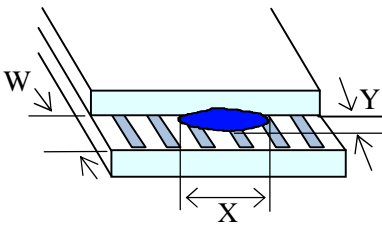
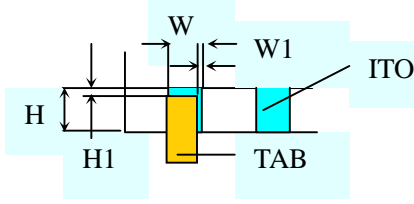
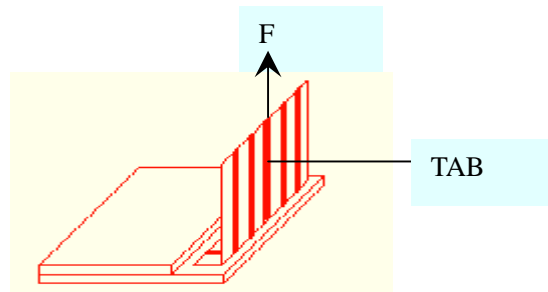
| No | Item                           | Criterion   |
|----|--------------------------------|---|
| 12 | Protruded<br>W: Terminal Width |  <p>Acceptable criteria:<br/><math>Y \leq 0.4</math></p>   |
| 13 | TAB                            | <p>1. Position</p>  <div style="border: 1px solid black; padding: 5px; width: fit-content; margin-left: auto; margin-right: auto;"> <math>W1 \leq 1/3W</math><br/> <math>H1 \leq 1/3H</math> </div> <p>2. TAB bonding strength test</p>  <p><math>P (=F/TAB \text{ bonding width}) \geq 650\text{gf/cm}</math> ,(speed rate: 1mm/min)<br/>           5pcs per SOA (shipment)</p> |
| 14 | Total no. of acceptable Defect | <p>A. Zone</p> <p>Maximum 2 minor non-conformities per one unit.<br/>           Defect distance: each point to be separated over 10mm</p> <p>B. Zone</p> <p>It is acceptable when it is no trouble for quality and assembly in customer's end product.</p>  |

### 14.3 Reliability of LCM

Reliability test condition:

| Item                 | Condition                                     | Time (hrs) | Assessment                                   |
|----------------------|---|------------|--|
| High temp. Storage   | 80°C  | 48         | No abnormalities in functions and appearance |
| High temp. Operating | 70°C  | 48         |  |
| Low temp. Storage    | -30°C   | 48         |  |
| Low temp. Operating  | -20°C   | 48         |  |
| Humidity             | 40°C/ 90%RH                                   | 48         |  |
| Temp. Cycle          | 0°C ← 25°C → 50°C<br>(30 min ← 5 min → 30min) | 10cycles   |  |

Recovery time should be 24 hours minimum. Moreover, functions, performance and appearance shall be free from remarkable deterioration within 50,000 hours under ordinary operating and storage conditions room temperature (20±8°C), normal humidity (below 65% RH), and in the area not exposed to direct sun light.

### 14.4 Precaution for using LCD/LCM

LCD/LCM is assembled and adjusted with a high degree of precision. Do not attempt to make any alteration or modification. The followings should be noted.

#### General Precautions:

1. LCD panel is made of glass. Avoid excessive mechanical shock or applying strong pressure onto the surface of display area.
2. The polarizer used on the display surface is easily scratched and damaged. Extreme care should be taken when handling. To clean dust or dirt off the display surface, wipe gently with cotton, or other soft material soaked with isopropyl alcohol, ethyl alcohol or trichlorotrifluoroethane, do not use water, ketone or aromatics and never scrub hard.
3. Do not tamper in any way with the tabs on the metal frame.
4. Do not make any modification on the PCB without consulting LONGTECH
5. When mounting a LCM, make sure that the PCB is not under any stress such as bending or twisting. Elastomer contacts are very delicate and missing pixels could result from slight dislocation of any of the elements.
6. Avoid pressing on the metal bezel, otherwise the elastomer connector could be deformed and lose contact, resulting in missing pixels and also cause rainbow on the display.
7. Be careful not to touch or swallow liquid crystal that might leak from a damaged cell. Any liquid crystal adheres to skin or clothes, wash it off immediately with soap and water.

#### Static Electricity Precautions:

1. CMOS-LSI is used for the module circuit; therefore operators should be grounded whenever he/she comes into contact with the module.
2. Do not touch any of the conductive parts such as the LSI pads; the copper leads on the PCB and the interface terminals with any parts of the human body.
3. Do not touch the connection terminals of the display with bare hand; it will cause disconnection or

defective insulation of terminals.

4. The modules should be kept in anti-static bags or other containers resistant to static for storage.
5. Only properly grounded soldering irons should be used.
6. If an electric screwdriver is used, it should be grounded and shielded to prevent sparks.
7. The normal static prevention measures should be observed for work clothes and working benches.
8. Since dry air is inductive to static, a relative humidity of 50-60% is recommended.

### **Soldering Precautions:**

1. Soldering should be performed only on the I/O terminals.
2. Use soldering irons with proper grounding and no leakage.
3. Soldering temperature:  $280^{\circ}\text{C} \pm 10^{\circ}\text{C}$
4. Soldering time: 3 to 4 second.
5. Use eutectic solder with resin flux filling.
6. If flux is used, the LCD surface should be protected to avoid spattering flux.
7. Flux residue should be removed.

### **Operation Precautions:**

1. The viewing angle can be adjusted by varying the LCD driving voltage  $V_o$ .
2. Since applied DC voltage causes electro-chemical reactions, which deteriorate the display, the applied pulse waveform should be a symmetric waveform such that no DC component remains. Be sure to use the specified operating voltage.
3. Driving voltage should be kept within specified range; excess voltage will shorten display life.
4. Response time increases with decrease in temperature.
5. Display color may be affected at temperatures above its operational range.
6. Keep the temperature within the specified range usage and storage. Excessive temperature and humidity could cause polarization degradation, polarizer peel-off or generate bubbles.
7. For long-term storage over  $40^{\circ}\text{C}$  is required, the relative humidity should be kept below 60%, and avoid direct sunlight.