

Evaluating the AD7176-2 24-Bit, 250 kSPS Sigma-Delta ADC with 20 μ s Settling

FEATURES

- Full featured evaluation board for the [AD7176-2](#)
- PC control in conjunction with the system demonstration platform ([EVAL-SDP-CB1Z](#))
- PC software for control and data analysis (time domain)
- Standalone capability

EVALUATION KIT CONTENTS

- [EVAL-AD7176-2SDZ](#) evaluation board
- AD717x Eval+ software CD
- 7 V to 9 V ac to dc adapter
- Plastic screw washer set

EQUIPMENT NEEDED

- DC signal source
- PC running Windows® XP to Windows 10
- USB cable

DOCUMENTS NEEDED

- [AD7176-2](#) data sheet
- [EVAL-AD7176-2SDZ](#) user guide

GENERAL DESCRIPTION

The [EVAL-AD7176-2SDZ](#) evaluation kit features the [AD7176-2](#) 24-bit, 250 kSPS analog-to-digital converter (ADC). A 7 V to 9 V external bench top supply is regulated to 5 V and 3.3 V to supply the [AD7176-2](#) and support all necessary components. The [EVAL-AD7176-2SDZ](#) evaluation board connects to the USB port of the PC by connection to the [EVAL-SDP-CB1Z](#) controller board.

The AD717x Eval+ software fully configures the [AD7176-2](#) device functionality via an interactive block diagram and a user accessible register interface and provides dc time domain analysis in the form of waveform graphs, histograms, and associated noise analysis for ADC performance evaluation.

Full specifications for the [AD7176-2](#) are available in the product data sheet, which must be consulted in conjunction with this user guide when using the [EVAL-AD7176-2SDZ](#) evaluation board.

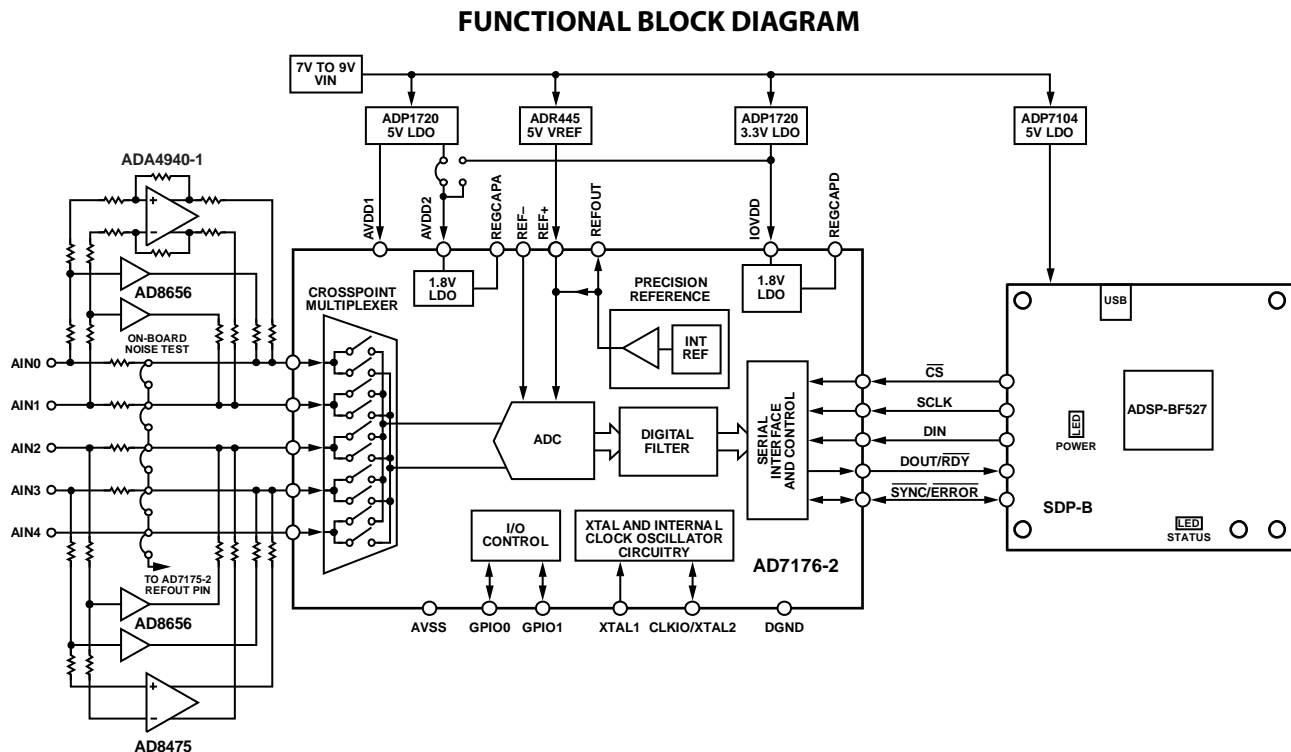

Figure 1. [EVAL-AD7176-2SDZ](#) Functional Block Diagram

TABLE OF CONTENTS

Features	1	Software Installation	12
Evaluation Kit Contents.....	1	Warning.....	12
Equipment Needed.....	1	Installing the AD717x Eval+ Software	12
Documents Needed.....	1	Installing the Eval+ Dependencies.....	13
General Description	1	Installing .NET Framework 3.5 on Windows 8/Windows 10...	13
Functional Block Diagram	1	Setting Up the System for Data Capture	14
Revision History	2	Launching the Software.....	14
EVAL-AD7176-2SDZ Quick Start Guide.....	4	Evaluation Board Software Operation.....	15
Evaluation Board Hardware.....	5	Overview of the Main Window.....	15
Device Description.....	5	Waveform Tab (18).....	17
Hardware Link Options.....	5	Histogram Tab (28).....	18
Sockets and On-Board Connectors	6	Modelled Performance Tab (31).....	19
Power Supplies	7	Registers Tab (45).....	22
Serial Interface	7	Exiting the Software.....	22
Analog Inputs.....	7	Evaluation Board Schematics and Artwork.....	23
Reference Options	8	Ordering Information.....	32
Using the On-Board Amplifiers	8	Bill of Materials.....	32
Evaluation Board Software	12		

REVISION HISTORY

4/2018—Rev. A to Rev. B

Changed AD7176-2 Eval Board to AD717x Eval+ ... Throughout		Changed Installing the EVAL-SDP-CB1Z System Demonstration	
Changes to Title, Equipment Needed Section, and General		Platform Board Drivers Section to Installing the Eval+	
Description Section.....	1	Dependencies Section.....	13
Deleted Online Resources Section	1	Changes to Figure 10, Installing the Eval+ Dependencies	
Added Evaluation Kit Contents Section and Documents		Section, Figure 11, and Figure 12	13
Needed Section	1	Added Installing .NET Framework 3.5 on Windows 8/Windows	
Changes to EVAL-AD7176-2SDZ Quick Start Guide Section ...	4	10 Section and Figure 14; Renumbered Sequentially	13
Changes to Table 1.....	5	Added Figure 16 and Figure 18	14
Changed On-Board Connectors Section to Sockets and On-		Changes to Figure 17.....	14
Board Connectors Section.....	6	Changed Software Operation Section to Evaluation Board	
Changes to Sockets and On-Board Connectors Section.....	6	Software Operation Section	15
Changes to Table 2.....	6	Changes to Overview of the Main Window Section	15
Changes to Serial Interface Section.....	7	Added Figure 19, Configuration Tab (1) Section, Select	
Deleted Sockets/Connectors Section and Table 4; Renumbered		Product/Evaluation Mode (2) Section, Tutorial Button (3)	
Sequentially	7	Section, Functional Block Diagram (4) Section, Configuration	
Changes to Reference Options Section.....	8	Pop-Up Button (5) Section, and Analog and Digital Supply	
Deleted Figure 3 and Figure 4; Renumbered Sequentially.....	8	Voltages (6, 7, and 14) Section.....	15
Changes to Figure 4.....	9	Deleted ADC Setup Button Section, Start Sampling Button	
Changes to Table 4.....	9	Section, Data Graph Section, Analysis Graph Section, CRC	
Changes to Figure 5.....	10	Error Indicator Section, and Figure 20.....	16
Deleted Evaluation Board Setup Procedures Section, Warning		Added Figure 20, External Reference (Ext. REF-(V) and Ext.	
Section, and Configuring the Evaluation and SDP Boards		REF+(V)) (8) Section, Register Configuration Summary (9)	
Section.....	11	Section, Reset ADC (10) Section, Menu Bar (11) Section, File	
Changed Software Installation Procedures Section to Software		Section, Save Section, Load Section, Exit Section, and Edit	
Installation Section.....	12	Section.....	16
Changes to Software Installation Section, Warning Section,		Deleted Noise Test—Quick Start Demonstration Section and	
Figure 6 Caption, Figure 7, Figure 8, and Figure 9.....	12	Figure 21	17

Added Help Section, Status Bar (12) Section, Device Error (13) Section, External MCLK Frequency (15) Section, Analog Input Voltage (16) Section, External SCLK Frequency (17) Section, Waveform Tab (18) Section, Sampling Mode (19) Section, Samples (20) Section, and Sample (21) Section.....17

Deleted Reading Samples from the ADC Section and Figure 22.....18

Added Figure 21, Waveform Graph and Controls (22 and 23) Section, Channel Selection (24) Section, Noise Analysis (25) Section, Analysis Channel (26) Section, Display Units and Axis Controls (27) Section, Histogram Tab (28) Section, and Histogram Graph and Controls Section.....18

Deleted DC Waveform Capture Section, DC Testing—Histogram Section, and Figure 23.....19

Added Figure 22, Figure 23, Modelled Performance Tab (31) Section, and Analysis Channel (32) Section.....19

Deleted Save File Section and Figure 24.....20

Added Filter Profile (33) Section, Filter Profile Graph (34) Section, Filter Rejection (35) Section, Filter Performance (36) Section, Figure 24, Filter Step Response (37) Section, Step Response Graph (38) Section, Step Configuration (39) Section, Step Response (40) Section, and Graph Units (41) Section.....20

Added Figure 25, Timing Power / Power (42) Section, Estimated Power Consumption (43) Section, and Timing Diagram (44) Section.....21

Added Figure 26, Registers Tab (45) Section, Register Tree (46) Section, Register (47) Section, Bitfields (48) Section, Documentation (49) Section, and Save (50) and Load (51) Section22

Changes to Exiting the Software Section.....22

Changes to Figure 27.....23

Changes to Figure 28.....24

Changes to Figure 29.....25

Changes to Figure 31.....27

Added Ordering Information Section.....32

Changes to Bill of Materials Section.....32

Changes to Table 7.....32

4/2014—Rev. 0 to Rev. A

Changes to the Reference Options Section.....8

11/2012—Revision 0: Initial Version

EVAL-AD7176-2SDZ QUICKSTART GUIDE

To begin using the [EVAL-AD7176-2SDZ](#) evaluation board, do the following:

1. Disconnect the [EVAL-SDP-CB1ZSDP-B](#) evaluation board from the USB port of the PC. Install the **AD717x Eval+** software from the enclosed CD. Restart the PC after installation.
2. Connect the [EVAL-SDP-CB1Z](#) evaluation board to the [EVAL-AD7176-2SDZ](#) evaluation board as shown in Figure 2.
3. Screw the two evaluation boards together using the plastic screw washer set included in the evaluation board kit to ensure that the evaluation boards are connected firmly together.
4. Connect the external 9 V power supply to the J5 connector of the [EVAL-AD7176-2SDZ](#) evaluation board, as shown in Figure 2. Set LK2 to Position B.
5. Connect the [EVAL-SDP-CB1Z](#) evaluation board to the PC using a USB cable. If you are using Windows XP, you may need to search for the [EVAL-SDP-CB1Z](#) drivers. Choose to automatically search for the drivers for the [EVAL-SDP-CB1Z](#) evaluation board if prompted by the operating system.
6. Launch the **AD717x Eval+** software from the **Analog Devices** subfolder in the **Programs** menu.

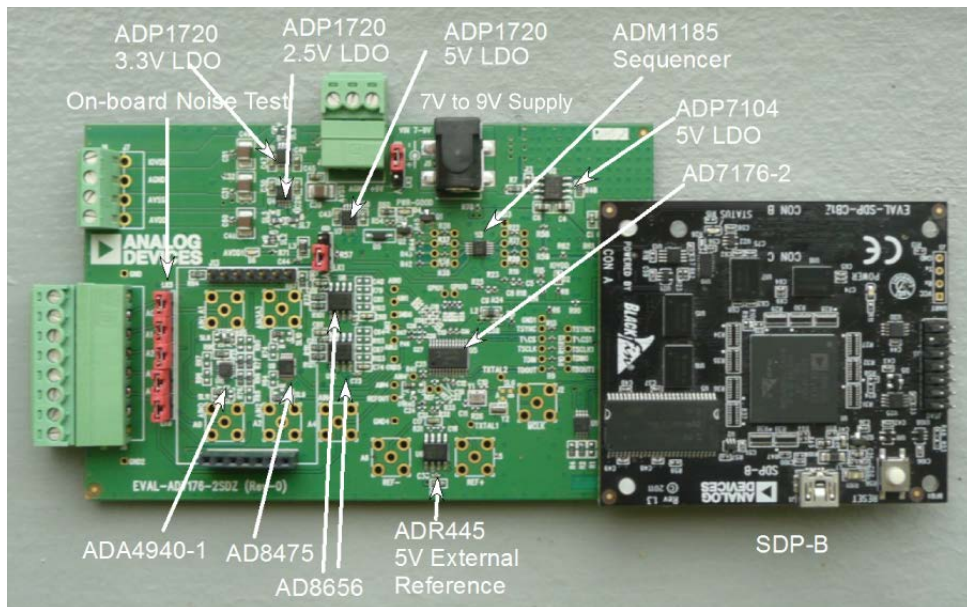

Figure 2. Setting Up the [EVAL-AD7176-2SDZ](#) Hardware Configuration

EVALUATION BOARD HARDWARE

DEVICE DESCRIPTION

The [AD7176-2](#) is a low noise, fast settling, multiplexed, 2-/4-channel (fully differential/pseudo differential) Σ - Δ ADC. The [AD7176-2](#) has a maximum channel to channel scan rate of 50 kSPS (20 μ s) for fully settled data. The output data rates range from 5 Hz to 250 kHz.

Complete specifications for the [AD7176-2](#) are provided in the product data sheet and must be consulted in conjunction with this user guide when using the [EVAL-AD7176-2SDZ](#) evaluation

board. Full details about the [EVAL-SDP-CB1Z](#) evaluation board are available on the Analog Devices, Inc., website.

HARDWARE LINK OPTIONS

The default link and solder link options are listed in Table 1. By default, the [EVAL-AD7176-2SDZ](#) evaluation board is configured to operate from the external bench top power supply via Connector J4. The supply required for the [AD7176-2](#) comes from the on-board [ADP1720](#) low dropout (LDO) generators, which generate input voltages from J4.

Table 1. Default Link and Solder Link Options

Link No.	Default Option	Description
LK1	A	Connects the AVDD1 voltage to the power supply sequencer, ADM1185 . When AVDD1 equals 5 V, LK1 must be in Position A. When AVDD1 equals 2.5 V, LK1 must be in Position B.
LK2	A	Selects the connector for the external 7 V to 9 V power supply. In Position A, LK2 selects the external 7 V to 9 V power supply to come from Connector J4. In Position B, LK2 selects the external 7 V to 9 V power supply to come from Connector J5.
LK5 to LK9	Inserted	Inserting LK5 to LK9 sets up the on-board noise test. In this mode, all inputs are shorted to the REFOUT pin.
SL1	A	Sets the voltage applied to the AVDD2 pin. In Position A, SL1 sets the voltage applied to the AVDD2 pin to be the same voltage applied to the AVDD1 pin. In Position B, SL1 sets the voltage applied to the AVDD2 pin to be a 3.3 V supply from the ADP1720ARMZ-3.3-R7 (U10) regulator or from an external voltage. AVDD2 cannot be set to 3.3 V when AVDD1 equals 2.5 V and AVSS equals -2.5 V.
SL2	A	Sets the voltage applied to the AVDD1 pin. In Position A, SL2 sets the voltage applied to the AVDD1 pin to be a 5 V supply from the ADP1720ARMZ-5-R7 (U7) regulator or a 2.5 V supply from the ADP1720ARMZ-R7 (U4) regulator. In Position B, SL2 sets the voltage applied to the AVDD1 pin to be supplied from an external voltage source via Connector J9. When AVDD1 equals 2.5 V, AVSS can be set to -2.5 V using an external supply connected to Connector J9. The AVSS to AGND solder links must be removed when a split power supply is used.
SL3, SL7	A, A	With SL3 and SL7 in Position A, AVDD1 is supplied with 5 V from ADP1720ARMZ-5-R7 (U7) regulator. With SL3 and SL7 in Position B, AVDD1 is supplied with 2.5 V from the ADP1720ARMZ-R7 (U4) regulator.
SL4	A	With SL4 in Position A, the AIN4 analog input on the AD7176-2 device is connected to Connector J8. With SL4 in Position B, the AIN4 analog input is connected to the REFOUT pin of the AD7176-2 . With SL4 in Position C, the AIN4 analog input is connected to ground for use with four pseudo differential inputs, if required.
SL5	B	With SL5 in Position A, the IOVDD supply is provided from an external source via Connector J9. With SL5 in Position B, the 3.3 V supply is generated by the ADP1720ARMZ-3.3-R7 (U10) regulator. The evaluation system operates with 3.3 V logic.
SL6	Not Inserted	Allows an external crystal (XTAL) or clock to be used as the clock source for the AD7176-2 . With SL6 not inserted, a crystal is connected to the AD7176-2 . With SL6 in Position B, an external clock source can be supplied to the ADC.
SL8	B	With SL8 in Position A, the AIN1 analog input on the AD7176-2 device is connected to Connector J8. With SL8 in Position B, the analog input applied via Connector J8 is buffered using the AD8656 before being applied to the AIN1 pin. With SL8 in Position C, the analog input path includes the ADA4940-1 differential amplifier. In conjunction with AIN0, a single-ended to differential driver is implemented. With SL8 in Position D, AIN1 is connected to Header J10.

Link No.	Default Option	Description
SL9	B	With SL9 in Position A, the AIN2 analog input on the AD7176-2 device is connected to Connector J8. With SL9 in Position B, the analog input applied via Connector J8 is buffered using the AD8656 before being applied to the AIN2 pin. With SL9 in Position C, the analog input path includes the AD8475 amplifier. In conjunction with AIN3, an attenuating single-ended to differential driver is implemented.
SL10	B	With SL10 in Position A, the AIN3 analog input on the AD7176-2 device is connected to Connector J8. With SL10 in Position B, the analog input applied via Connector J8 is buffered using the AD8656 before being applied to the AIN3 pin. With SL10 in Position C, the analog input path includes the AD8475 amplifier. In conjunction with AIN2, an attenuating single-ended to differential driver is implemented.
SL11	B	With SL11 in Position A, the AIN0 analog input on the AD7176-2 device is connected to Connector J8. With SL11 in Position B, the analog input applied via Connector J8 is buffered using the AD8656 before being applied to the AIN0 pin. With SL11 in Position C, the analog input path includes the ADA4940-1 differential amplifier. In conjunction with AIN1, a single-ended to differential driver is implemented. With SL11 in Position D, AIN0 is connected to Header J10.
AVSS to AGND		When AVSS and AGND are inserted, AVSS is tied to AGND. When AVSS is set to -2.5 V, these links must be removed.

SOCKETS AND ON-BOARD CONNECTORS

Table 2. Connector Details

Connector	Function	Connector Type	Manufacturer	Manufacturer Number	Order Code ¹
J1	Connector to the EVAL-SDP-CB1Z	120-way connector, 0.6 mm pitch	Hirose	FX8-120S-SV(21)	FEC1324660
J2	External MCLK input	Straight printed circuit board (PCB), surface-mount Type B/Type A (SMB/SMA) jack	TE Connectivity	1-1337482-0	Not applicable
J3	External bench top voltage supply for the EVAL-AD7176-2SDZ	Power socket block, 3-pin, 3.81 mm pitch	Phoenix Contact	MC 1,5/3-G-3,81	FEC3704737
J5	External ac to dc adapter input for the EVAL-AD7176-2SDZ , 7 V to 9 V	DC power connectors, 2 mm surface-mount technology (SMT) power jack	Kycon	KLDX-SMT2-0202-A	MOUSER 806-KLDX-SMT20202A
J6	Analog input terminal block, wired connection to external source or sensor	Power socket block, 8-pin, 3.81 mm pitch	Phoenix Contact	MC 1,5/8-G-3,81	FEC3704774
J9	External bench top voltage supply option for AVDD1/AVDD2, IOVDD, and AVSS inputs on the AD7176-2	Screw terminal block, 3.81 mm pitch	Phoenix Contact	MKDS 1/4-3.81	FEC3704592
J10	External amplifier connector	7-way, 2.54 mm pin header	Samtec	SSW-107-01-T-S	FEC1803478
J13	Connects to AIN0/AIN1 analog inputs of ADC	7-way, 2.54 mm socket	Samtec	TLW-107-05-G-S	FEC1668499
A0 to A4	Analog inputs to ADC	Straight PCB mount SMB/SMA jack	TE Connectivity	1-1337482-0	Not applicable

¹ Order codes starting with FEC are for Farnell.

POWER SUPPLIES

The EVAL-AD7176-2SDZ evaluation board requires that an external power supply, either a bench top supply or a wall wart (dc plug) supply, be applied to J4 or J5 (see Table 3 for more information). Linear regulators generate the required power supply levels from the applied power supply (V_{IN}) rail. The regulators used are the 5 V ADP1720 (U7) and the 2.5 V ADP1720 (U4), which supply 5 V and 2.5 V, respectively, to AVDD1 and AVDD2 of the ADC. The 3.3 V ADP1720 (U10) delivers 3.3 V to the IOVDD pin of the AD7176-2.

When a split power supply is used, the AVSS voltage must be applied from an external source via Connector J9. AVDD1/AVDD2 and IOVDD can also be provided via Connector J9. However, the 7 V to 9 V supply is still required because the on-board reference (ADR445) is supplied from this power supply.

Each supply is decoupled at the point where it enters the EVAL-AD7176-2SDZ evaluation board and again at the point where it connects to each device (see the schematics shown in Figure 27 to Figure 31 to identify decoupling points).

SERIAL INTERFACE

The EVAL-AD7176-2SDZ evaluation board connects via the SPI to the Blackfin® ADSP-BF527 on the EVAL-SDP-CB1Z evaluation board. There are four primary signals: CS, SCLK,

DIN, and DOUT/RDY (all are inputs, except for DOUT/RDY, which is an output).

To operate the EVAL-AD7176-2SDZ evaluation board in standalone mode, the AD7176-2 serial interfacelines can be disconnected from the 120-pin header of the EVAL-SDP-CB1Z evaluation board by removing the 0 Ω links, R9 through R13. The test points can then be used to fly wire the signals to an alternative digital capture setup.

ANALOG INPUTS

The two ways to apply the EVAL-AD7176-2SDZ evaluation board primary analog inputs include the following:

- J8, the green screw in the terminal connector on the right side of the board.
- The A0 to A4 SMB/SMA footprints on the EVAL-AD7176-2SDZ evaluation board.

The AIN0 to AIN3 analog inputs are routed via the AD8656 buffers to the associated input pins on the AD7176-2, and the AIN4 analog input is connected to Connector J8 if LK5 to LK9 are removed, disabling the on-board noise test. The buffers are configured for a gain of 2.

The AD717x Eval+ software is set up to analyze dc inputs to the ADC.

Table 3. Required External Power Supply¹

V _{IN} Applied	Voltage Range (V)	Function
J4	7 to 9	Bench top supply to the EVAL-AD7176-2SDZ evaluation board. Supplies LDOs that create 5 V, 2.5 V, and 3.3 V rails. The J4 supply also supplies the ADR445 external reference. Ensure that LK2 is set to Position A when the external power supply is applied to this connector.
J5	7 to 9	Wall wart (dc plug) supply to the EVAL-AD7176-2SDZ evaluation board. Supplies LDOs that create 5 V, 2.5 V, and 3.3 V rails. The J5 supply also supplies the ADR445 external reference. Ensure that LK2 is set to Position B when the external power supply is applied to this connector.

¹ Only a single supply is required, either J4 or J5. This supply can be selected using LK2.

REFERENCE OPTIONS

The [EVAL-AD7176-2SDZ](#) evaluation board includes an external 5 V reference (the [ADR445](#)) and an internal 2.5 V reference. The default operation on the [AD7176-2](#) uses the internal 2.5 V reference.

The reference used for a conversion is selected by choosing the reference in the SETUPCONx registers associated with Setup 1, Setup 2, Setup 3, and Setup 4.

Switch between using the internal reference and external reference by accessing the [AD7176-2](#) register map via the [AD717x Eval+](#) software.

USING THE ON-BOARD AMPLIFIERS

The [EVAL-AD7176-2SDZ](#) evaluation board contains three front-end configurations. The [AD8656](#) is provided for buffering the analog inputs of the [AD7176-2](#). By default, the [AD8656](#) is configured for a gain of 2, and the front end is selected on the [EVAL-AD7176-2SDZ](#) evaluation board. The [ADA4940-1](#) amplifier provides a single-ended to differential driver, whereas the [AD8475](#) is configured to operate as an attenuating single-ended to differential driver. Figure 3 shows the location of the resistor and capacitor (R/C) components on the [EVAL-AD7176-2SDZ](#) evaluation board. Figure 4 and Figure 5 highlight the R/C components populated on the [EVAL-AD7176-2SDZ](#) evaluation board for each amplifier, and Table 4 to Table 6 list the component values.

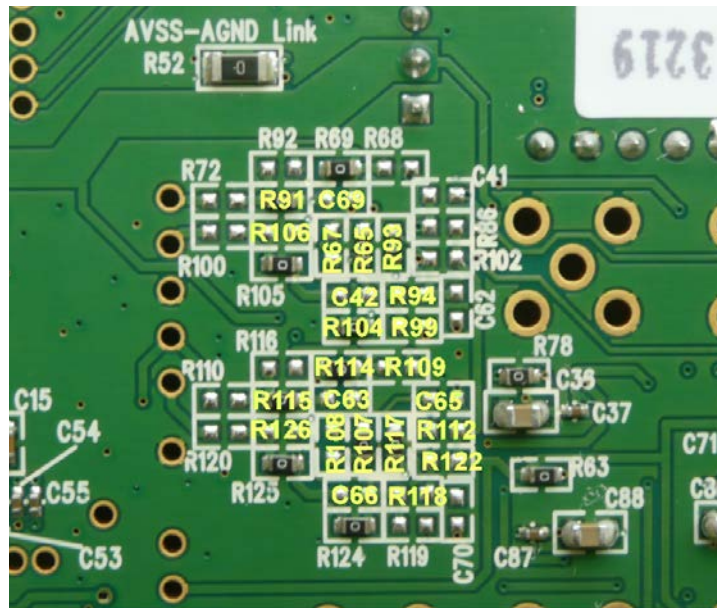
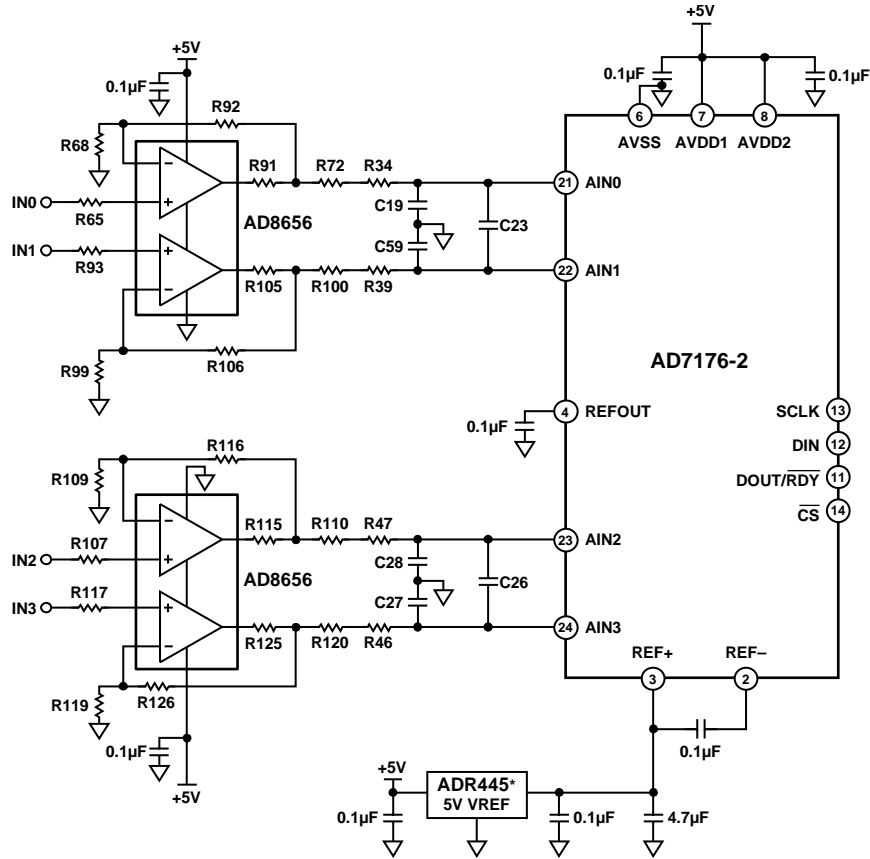

Figure 3. Identification of R/C Components for the Amplifiers



*USING ADR444 (4.096V REFERENCE) IN PLACE OF THE ADR445 ALLOWS THE ENTIRE CIRCUIT TO BE OPERATED FROM A SINGLE +5V SUPPLY RAIL.

11035-106

Figure 4. Setup for the AD8656 Amplifiers

Table 4. R/C Values Used with AD8656 Amplifiers (Gain = 2)

U8		U12	
Component	Status	Component	Status
R65	0 Ω	R107	0 Ω
R68	1 kΩ, ±0.1%	R109	1 kΩ, ±0.1%
R72 ¹	0 Ω	R110 ²	0 Ω
R91	10 Ω	R115	10 Ω
R92	1 kΩ, ±0.1%	R116	1 kΩ, ±0.1%
R93	0 Ω	R117	0 Ω
R99	1 kΩ, ±0.1%	R119	1 kΩ, ±0.1%
R100 ¹	0 Ω	R120 ²	0 Ω
R105	10 Ω	R125	10 Ω
R106	1 kΩ, ±0.1%	R126	1 kΩ, ±0.1%
R34	0 Ω	R46	0 Ω
R39	0 Ω	R47	0 Ω
C19	270 pF	C27	270 pF
C59	270 pF	C28	270 pF
C23	680 pF	C26	680 pF

¹ Remove R72 and R100 when connecting the ADA4940-1 to the AD7176-2.

² Remove R110 and R120 when connecting the AD8475 to the AD7176-2.

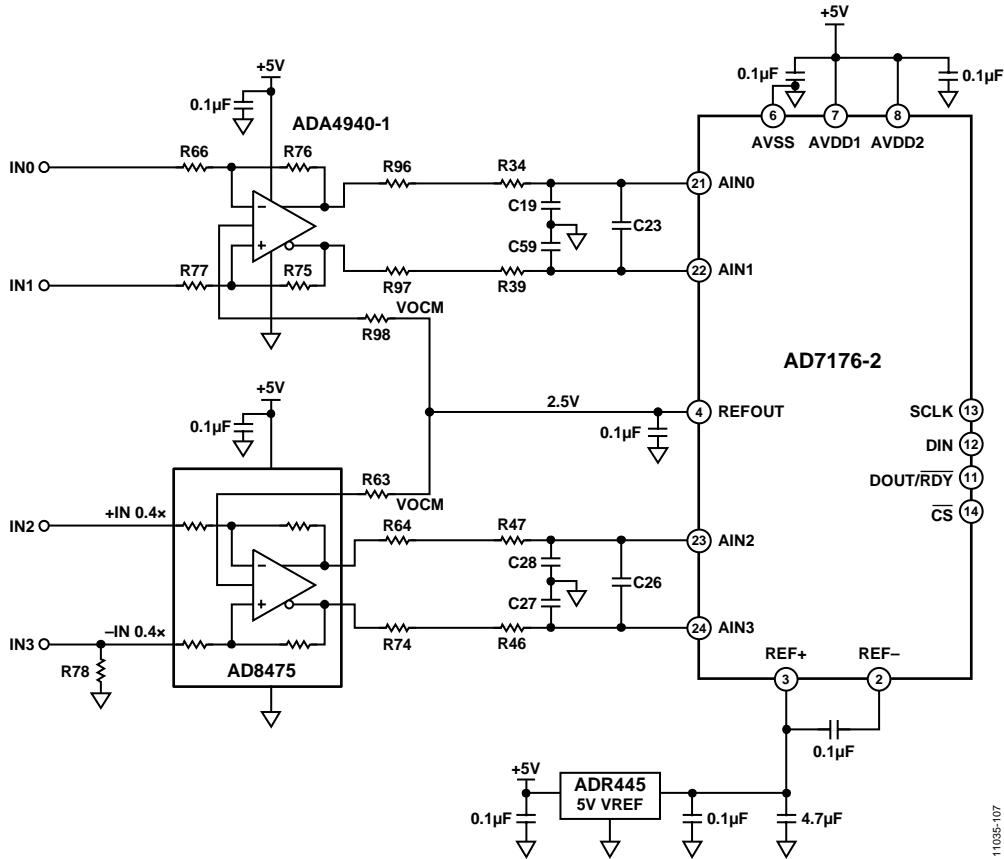

Figure 5. Setup for the ADA4940-1 and AD8475 Amplifiers

Table 5. R/C Components for ADA4940-1 (Single-Ended to Differential Driver)

Component	Status
R66	0 Ω
R75	0 Ω
R76	0 Ω
R77	0 Ω
R96 ¹	Not inserted
R97 ¹	Not inserted
R98	0 Ω
R34	0 Ω
R39	0 Ω
C19	270 pF
C59	270 pF
C23	680 pF

¹ Insert 0 Ω resistors in R96 and R97 to connect the ADA4940-1 to the AD7176-2, and place the SL8 and SL11 solder links in Position C. Ensure that the R72 and R100 resistors are removed.

Table 6. R/C Components for AD8475 (Attenuating Single-Ended to Differential Driver)

Component	Status
R63	0 Ω
R64 ¹	Not inserted
R74 ¹	Not inserted
R78	0 Ω
R46	0 Ω
R47	0 Ω
C27	270 pF
C28	270 pF
C26	680 pF

¹ Populate R64 and R74 with 10 Ω resistors to connect the AD8475 to the AD7176-2, and place the SL9 and SL10 solder links in Position C. Ensure that the R110 and R120 resistors are removed.

EVALUATION BOARD SOFTWARE SOFTWARE INSTALLATION

The **EVAL-AD7176-2SDZ** evaluation kit includes software on a CD. Double click the **setup.exe** file from the CD to run the installer. The default installation location for the software is **C:\Program Files (x86)\Analog Devices\AD717xEval+**.

Install the **AD717x Eval+** software before connecting the **EVAL-AD7176-2SDZ** evaluation board and the **EVAL-SDP-CB1Z** evaluation board to the USB port of the PC to ensure that the evaluation system is correctly recognized when connected to the PC. Install the following two parts:

1. **AD717x Eval+** software installation
2. **AD717x Eval+ Dependencies**
 - a. **EVAL-SDP-CB1Z** board drivers
 - b. **Ssrc SVG Plugin**
 - c. Microsoft **.NET Framework 3.5**

WARNING

To ensure that the PC correctly recognizes the evaluation system, the evaluation software drivers must be installed before connecting the **EVAL-AD7176-2SDZ** evaluation board and the **EVAL-SDP-CB1Z** evaluation board to the USB port of the PC.

INSTALLING THE AD717X EVAL+ SOFTWARE

To install the **AD717x Eval+** software, take the following steps:

1. With the **EVAL-SDP-CB1Z** evaluation board disconnected from the USB port of the PC, insert the CD into the CD ROM drive.
2. Double click the **setup.exe** file to begin the evaluation board software installation. The default installation location for the software is **C:\Program Files\Analog Devices\AD717x Eval+**.
3. A dialogue box appears asking for permission to allow the program to make changes to the PC (see Figure 6). Click **Yes**.

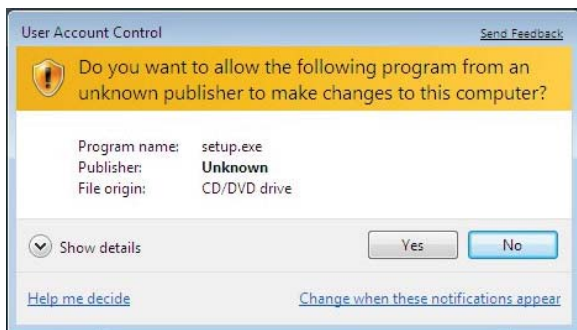

Figure 6. **User Account Control**, Permission Dialog Box

4. Select a location to install the software and click **Next**. Figure 7 shows the default locations displayed when the dialogue box opens. To select another location, click **Browse**.

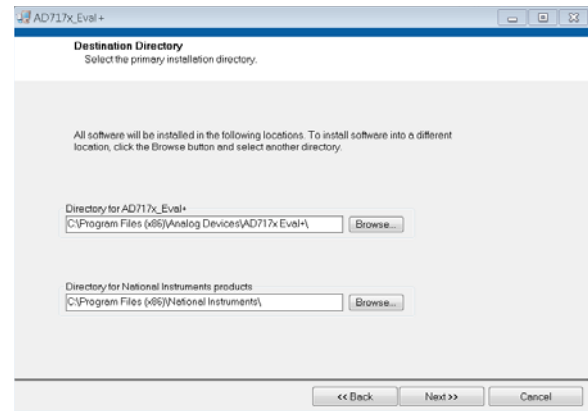

Figure 7. **AD717x Eval+**, Selecting the Location for Software Installation

5. A license agreement appears. Read the agreement, select **I accept the License Agreement**, and click **Next**.

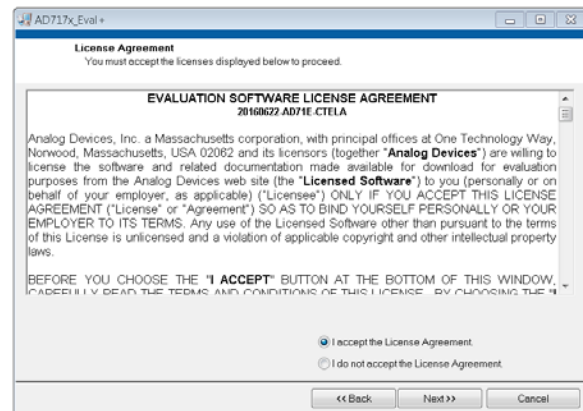

Figure 8. **AD717x Eval+**, Accepting the License Agreement

6. A summary of the installation displays. Click **Next** to continue.

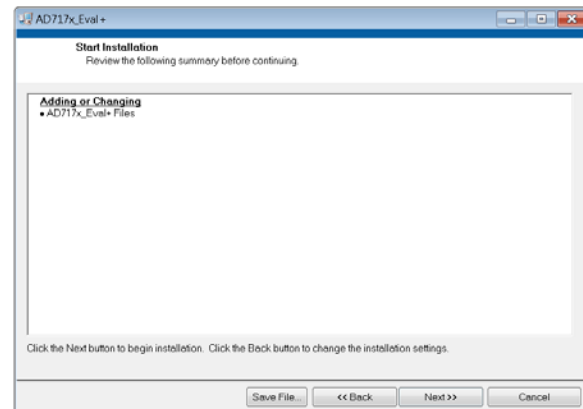

Figure 9. **AD717x Eval+**, Reviewing a Summary of the Installation

- The message in Figure 10 appears when the installation is complete. Click **Next** to continue.

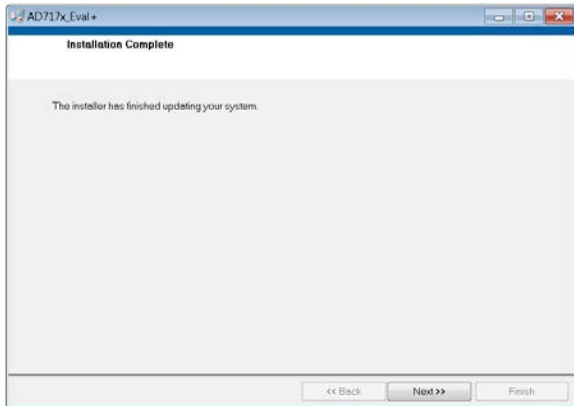

Figure 10. AD7176x Eval+ Installation Complete

INSTALLING THE EVAL+ DEPENDENCIES

After the installation of the evaluation software is complete, use the following procedure to install the **Eval+ Dependencies**:

- With the **EVAL-SDP-CB1Z** evaluation board still disconnected from the USB port of the PC, make sure all other applications are closed, and then click **Install**.

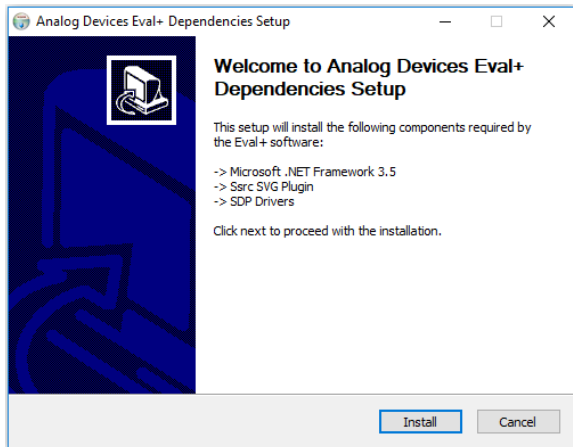

Figure 11. Eval+ Dependencies Setup, Beginning the Drivers Installation

- The **Ssrc SVG Plugin** installs first, the **SDP Drivers**, and finally the **.NET Framework 3.5**.
- If you are using Windows 8 or Windows 10, see the **Installing .NET Framework 3.5 on Windows 8/Windows 10** section.
- To complete the drivers installation and close the installation setup wizard, click **Close**.

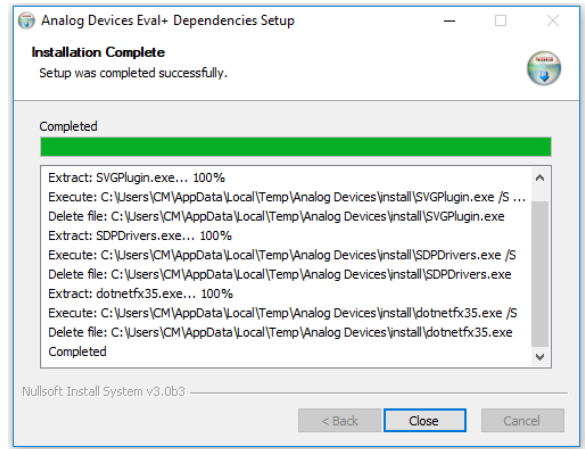

Figure 12. Eval+ Dependencies Setup, Completing the Drivers Setup Wizard

- Before using the **EVAL-AD7176-2SDZ** evaluation board, you must restart the PC.

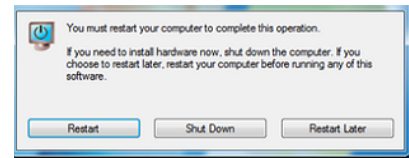

Figure 13. Restarting the PC

INSTALLING .NET FRAMEWORK 3.5 ON WINDOWS 8/WINDOWS 10

Windows 8 and Windows 10 have a built in installer for the **.NET Framework 3.5**. To run this, an internet connection is needed, as well as administrator privileges. If the following steps do not work, contact a system administrator:

- When the **Eval+ Dependencies** installer reaches the **.NET Framework 3.5**, the window shown in Figure 14 appears.

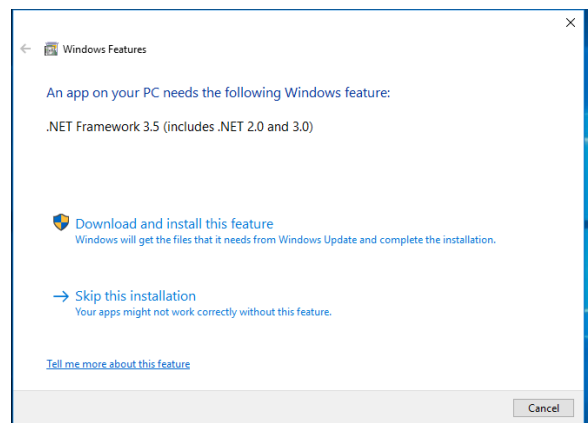

Figure 14. Windows 8/10 .NET Framework 3.5 Installation

- Follow the steps in the installation setup wizard to complete the installation.
- If the wizard does not appear, then **.NET Framework 3.5** may already be installed. To check, open **Control Panel > Programs > Programs and Features** and select **Turn**

Windows features on or off. In the window that appears, look for **.NET Framework 3.5** and check that it is enabled.

SETTING UP THE SYSTEM FOR DATA CAPTURE

After completing the steps in the Evaluation Board Hardware and the Software Installation sections, set up the system for data capture using the following:

1. Allow the **Found New Hardware Wizard** to run after the [EVAL-SDP-CB1Z](#) evaluation board is connected to the PC. If using Windows XP, search for the [EVAL-SDP-CB1Z](#) drivers. Choose to automatically search for the drivers if prompted by the operating system.
2. Check that the [EVAL-AD7176-2SDZ](#) evaluation board is connecting to the PC correctly using the **Device Manager**. Access the **Device Manager** by completing the following steps:
 - a. Right click **My Computer** and then click **Manage**.
 - b. A dialog box appears asking for permission to allow the program to make changes to the PC. Click **Yes**.
 - c. The **Computer Management** window appears. Click **Device Manager** from the list of **System Tools** (see Figure 15).
 - d. The [EVAL-SDP-CB1Z](#) evaluation board appears under **ADI Development Tools**, which indicates that the driver software has installed and that the [EVAL-SDP-CB1Z](#) evaluation board is connecting to the PC correctly.

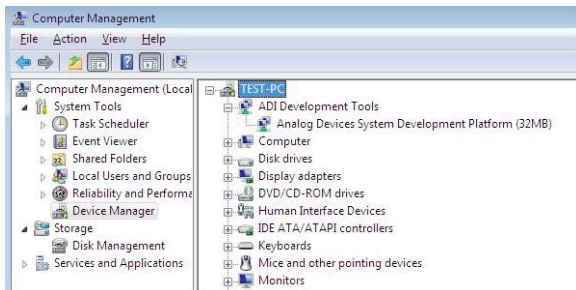

Figure 15. **Device Manager**, Checking the Board Connects to the PC Correctly

LAUNCHING THE SOFTWARE

After completing the steps in the Setting Up the System for Data Capture section, launch the **AD717x Eval+** software using the following steps:

1. From the **Start** menu, click **Programs > Analog Devices > AD717x_Eval+ > AD717x Eval+**.
2. The dialogue box in Figure 16 appears. Select **AD7176-2 Evaluation Board**. The main window of the software box displays as shown in Figure 19.

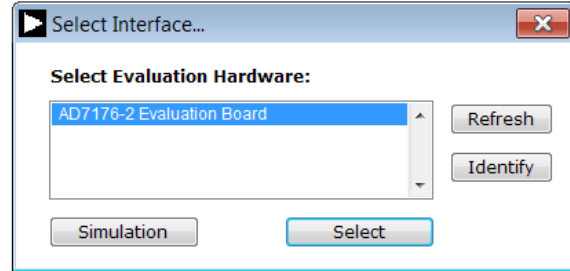

Figure 16. **AD7176-2** Evaluation Board Selection

3. If the [EVAL-AD7176-2SDZ](#) evaluation system is not connected to the USB port via the [EVAL-SDP-CB1Z](#) evaluation board when the software is launched, the software displays the dialog box shown in Figure 17. Connect the [EVAL-SDP-CB1Z](#) evaluation board to the USB port of the PC. Wait a few seconds, click **Refresh** and the option shown in Figure 16 appears.

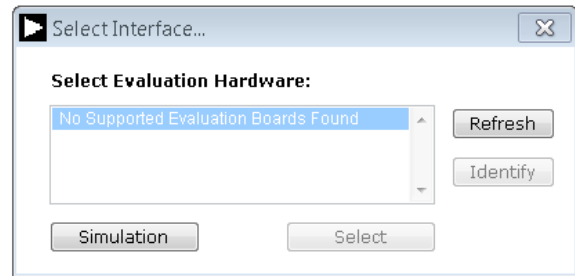

Figure 17. Evaluation Board Selection, No Board Connected

4. The **AD717x Eval+** can also be used without connecting hardware. Click the **Simulation** button and the options shown in Figure 18 appear. The **Simulation** mode uses a software model and allows the [AD7172-2](#), [AD7172-4](#), [AD7173-8](#), [AD7175-2](#), [AD7175-8](#), [AD7176-2](#), or [AD7177-2](#) to be evaluated.

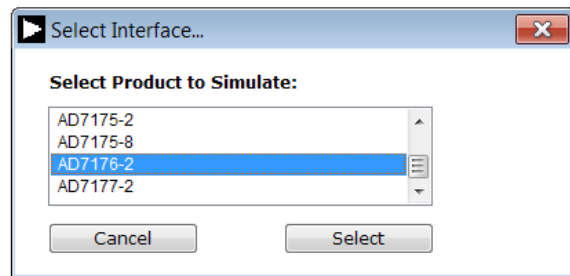

Figure 18. Evaluation Board Selection Simulation

EVALUATION BOARD SOFTWARE OPERATION

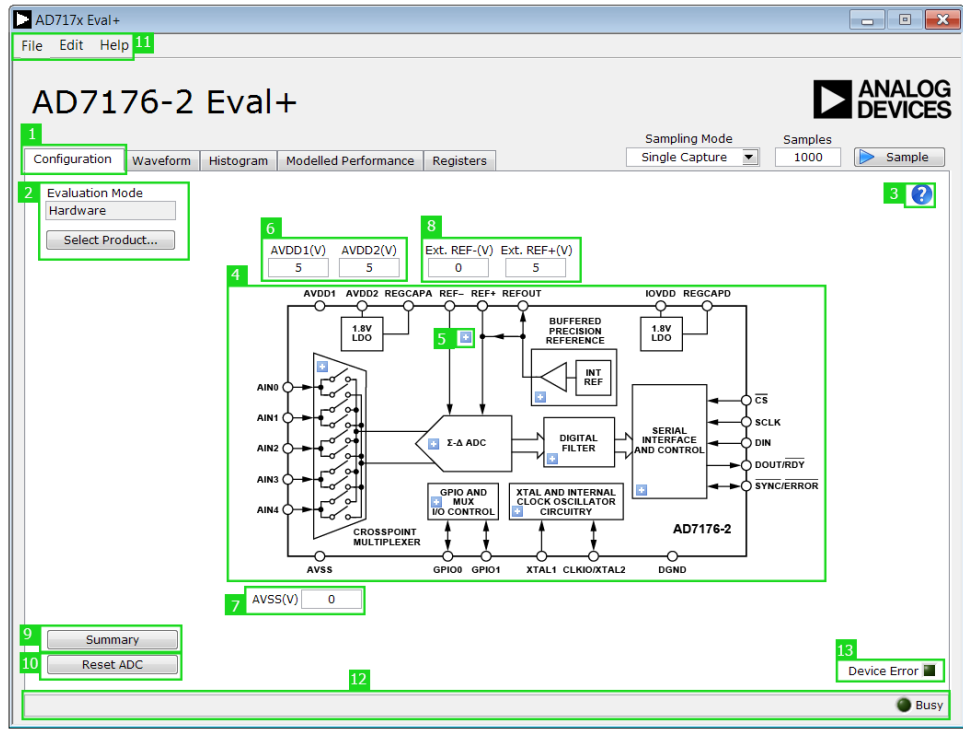

Figure 19. Configuration Tab of the AD7176-2 Evaluation Software in Hardware Mode

OVERVIEW OF THE MAIN WINDOW

The main window of the AD717x Eval+ software displays the significant control buttons and analysis indicators of the AD717x Eval+ software. This window is divided into five tabs.

- Configuration (1)
- Waveform (18)
- Histogram (28)
- Modelled Performance (31)
- Registers (45)

Configuration (1) Tab

Figure 19 shows the Configuration (1) tab when Hardware mode is selected, and Figure 20 shows the Configuration (1) tab when Simulation mode is selected. The controls highlighted in Figure 20 are only available in Simulation mode.

Select Product/Evaluation Mode (2)

The Evaluation Mode (2) indicator displays the current evaluation mode. To switch between modes, click the Select Product (2) button and the dialog box shown in Figure 16 appears.

Tutorial Button (3)

Click the tutorial button (3) to open a tutorial and additional information on using the AD717x Eval+ software.

Functional Block Diagram (4)

The functional block diagram (4) of the ADC shows each of the separate functional blocks within the ADC. Clicking a configuration button on any of the functional blocks opens the configuration pop up window for the block selected. Not all blocks have a configuration button.

Configuration Pop Up Button (5)

Each configuration pop up button (5) opens a different window that allows the configuration of the relevant functional block.

Analog and Digital Supply Voltages (6, 7, and 14)

Use these input fields to record the supply voltage levels selected for the AD7176-2. Checks are performed to ensure that the power supply voltage levels entered are within the specified limits. These power supply voltage levels are also used for the modeled performance to calculate the power dissipation.

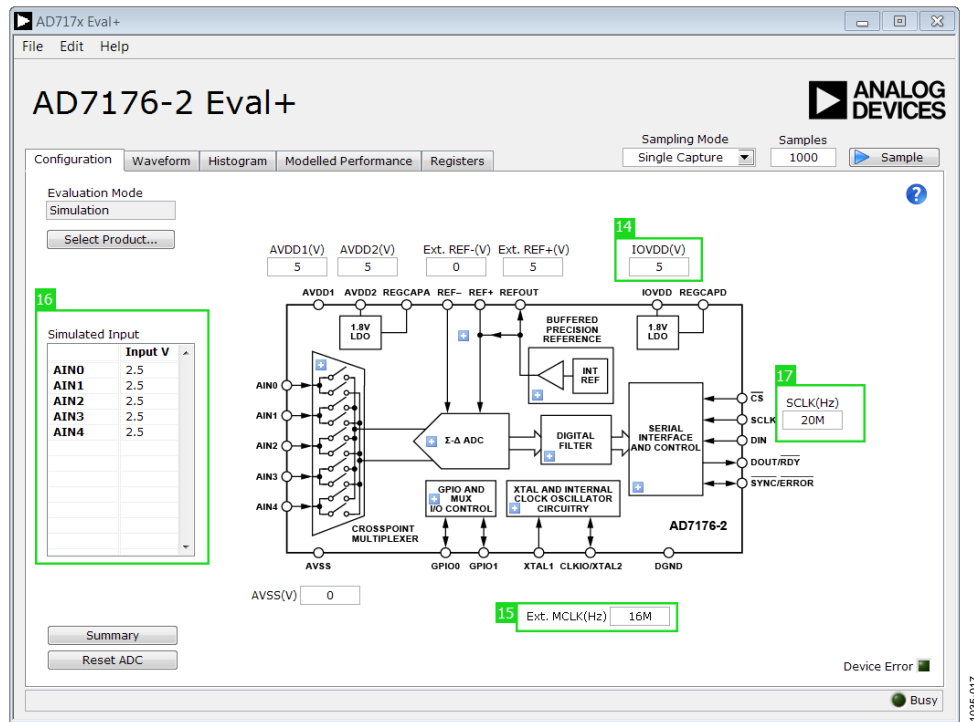

Figure 20. Configuration Tab of the AD7176-2 Evaluation Software in Simulation Mode

External Reference (Ext. REF-(V) and Ext. REF+(V)) (8)

The **Ext. REF-(V)** (8) and **Ext. REF+(V)** (8) input fields set the positive and negative external reference voltage values (see Figure 19). The difference is used in calculating the results for both the **Waveform** (18) and **Histogram** (28) tabs, shown in Figure 21 and Figure 22, respectively. The **EVAL-AD7176-2SDZ** evaluation board has an external 5 V **ADR445** reference that can be bypassed by removing R32. Change the external reference voltage value in **Ext. REF-(V)** (8) and **Ext. REF+(V)** (8) to ensure correct calculation of results in the **Waveform** (18) and **Histogram** (28) tabs.

Register Configuration Summary (9)

Click the **Summary** (9) button to display the selected configuration of the **AD7176-2**. Configurations include channel configuration, information on each of the individual setups, as well as information on any error present (see Figure 19).

Reset ADC (10)

Click the **Reset ADC** (10) button, shown in Figure 19, to perform a software reset of the **AD7176-2**. The **AD7176-2** does not have a hardware reset pin. To perform a hard reset, the power must be removed from the **EVAL-AD7176-2SDZ** evaluation board. The software reset has the same effect as a hard reset.

Menu Bar (11)

The menu bar (11), shown in Figure 19, has three sections: **File**, **Edit**, and **Help**.

File

Three options are available in the **File** menu: **Save**, **Load**, and **Exit**

Save

In **Save**, register configurations or waveform data can be saved. Register configurations can be saved as a JSON file or a header file. If the configuration is only used in the **AD717x Eval+** software environment, the recommended setting to use is the JSON. Waveforms are saved as .csv files, and there is a prompt to save the register configuration as well.

Load

In **Load**, saved register configurations or waveform data can be loaded. To load a header file into **AD717x Eval+**, the header must be in the same format as one that is saved from **AD717x Eval+**. The header file can be used when developing firmware. When loading the waveform data, there is a prompt to load the register configuration so that the software can correctly analyze the data.

Exit

Click **Exit** to close the **AD717x Eval+** software.

Edit

Two options are available in the **Edit** dropdown menu: **Change Product Selection** and **Reset ADC**. **Change Product Selection** performs the same action as the **Select Product** (2) control and **Reset ADC** performs the same action as the **Reset ADC** (10) button (see Figure 19).

Help

The **Help** dropdown menu provides links to extra information about the [AD7176-2](#), which includes links to the product page, [EVAL-AD7176-2SDZ](#) evaluation board user guide, data sheet, and No OS drivers. Selecting the **AD717x Eval+** tutorial opens the tutorial outlined in the Tutorial Button (3) section. For details on the version of the software, the **About** option opens a dialog box displaying the current version of the software and the relevant licenses.

Status Bar (12)

The status bar (12) displays the busy indicator and status updates, such as **Analysis Completed** and **Reset Completed** during software use (see Figure 19).

Device Error (13)

The **Device Error** (13) light emitting diode (LED) icon, shown in Figure 19, illuminates when a when an ADC error is detected or when a cyclic redundancy check (CRC) error occurs. The CRC functionality on the [AD7176-2](#) is disabled by default and must be enabled for this indicator to work. More specific information on the error can be found in the Register Configuration Summary (9) section.

External MCLK Frequency (15)

This field sets the external MCLK frequency (15) (see Figure 20). The external MCLK frequency is only visible on the front panel when an external clock source is selected by the ADC. The external MCLK frequency is used by the functional model for the **Modelled Performance** (31) tab, shown in Figure 23.

Analog Input Voltage (16)

These input fields are only available when the **AD717x Eval+** software is executed in **Simulation** mode. These inputs allow

the analog input voltages (16) to be set and can be changed at any time while in **Simulation** mode (see Figure 20).

External SCLK Frequency (17)

This input field sets the external **SCLK** frequency (17) for the SPI interface. This field is only available in **Simulation** mode to determine if the **SCLK** frequency (17) is within the permitted range (see Figure 20).

WAVEFORM TAB (18)

Figure 21 shows the **Waveform** (18) tab of the **AD717x Eval+** Software.

Sampling Mode (19)

This control, shown in Figure 21, is unrelated to the ADC mode. A defined sample set can be captured in a single capture, or batches of samples can be continuously gathered in a repeated capture. Data logging that runs like repeated capture but posts the results to a .csv file can also be selected. When saving, the .csv file prompts to save the register configuration, which is necessary for the analysis of the data to load back into the software.

Samples (20)

The **Samples** (20) numeric control sets the number of **Samples** (20) gathered per batch. Single capture returns the number entered in the **Samples** (20) control. A repeated capture keeps returning batches of the number in **Samples** (20) until stopped (see Figure 21).

Sample (21)

Click the **Sample** (21) button to start gathering ADC results. Results appear in the **Waveform** (22) graph. Both the **Sample** (21) button and the **Waveform** (22) graph are shown in Figure 21.

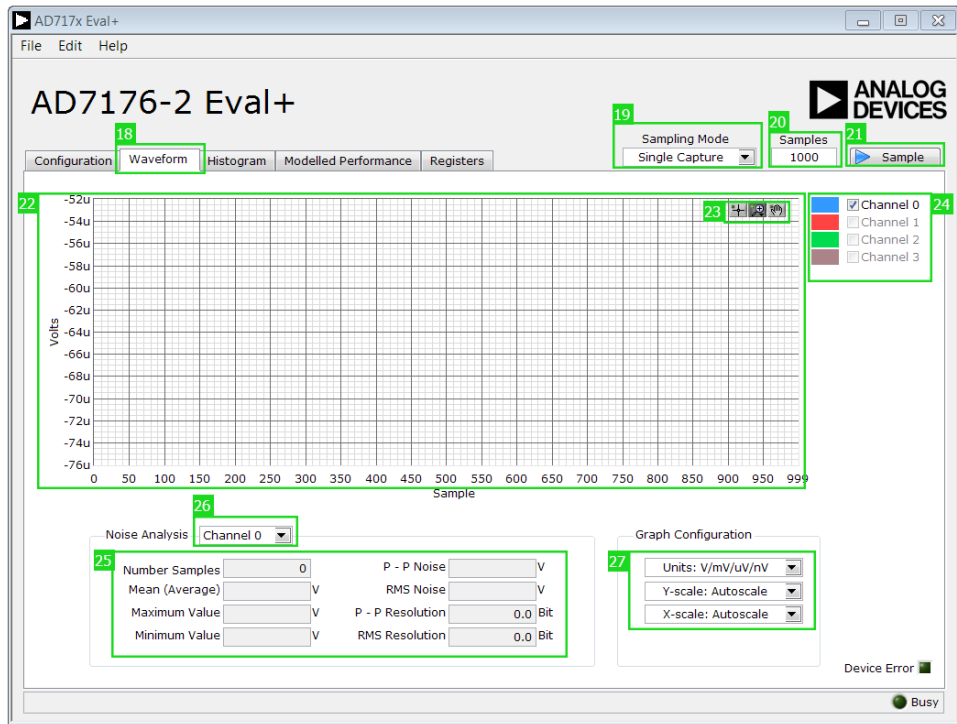

Figure 21. **Waveform** Tab of the AD7176-2 Evaluation Software

Waveform Graph and Controls (22 and 23)

The data **Waveform** (22) graph shows each successive sample of the ADC output. Zoom in on the data using the control toolbar (23). Click the x-axis and y-axis to change the scales on the graph. (see Figure 21).

Channel Selection (24)

The channel selection (24) control, shown in Figure 21, allows you to choose which channels display on the data **Waveform** (22) graph. These controls only affect the display of the channels and do not have any effect on the channel settings in the ADC register map.

Noise Analysis (25)

The **Noise Analysis** (25) section displays the results of the **Noise Analysis** (25) for the selected analysis channel; this section includes both noise and resolution measurements (see Figure 21).

Analysis Channel (26)

The **Noise Analysis** (25) section and **Histogram** (29) graph (see Figure 22) show the analysis of the channel selected via the analysis channel dropdown menu, shown in Figure 21.

Display Units and Axis Controls (27)

Click the **Units** (27) dropdown menu to select the unit the data displays in the graph. This control affects both the **Waveform** (22) graph and the **Histogram** (29) graph. The axis controls can switch between **Dynamic** and **Fixed**. When **Dynamic** is selected, the axis automatically adjusts to show the entire range of the ADC results after each batch of samples. When **Fixed** is selected, the axis ranges can be programmed. The axis ranges do not automatically adjust after each batch of samples (see Figure 21).

HISTOGRAM TAB (28)

Figure 22 shows the **Histogram** (28) tab of the AD717x Eval+ software.

Histogram Graph and Controls

The data **Histogram** (29) graph shows the number of times each sample of the ADC output occurs. The control toolbar (30) in the **Histogram** (29) graph allows you to zoom in on the data. Click the x-axis and y-axis to change the scales on the graph (see Figure 22).

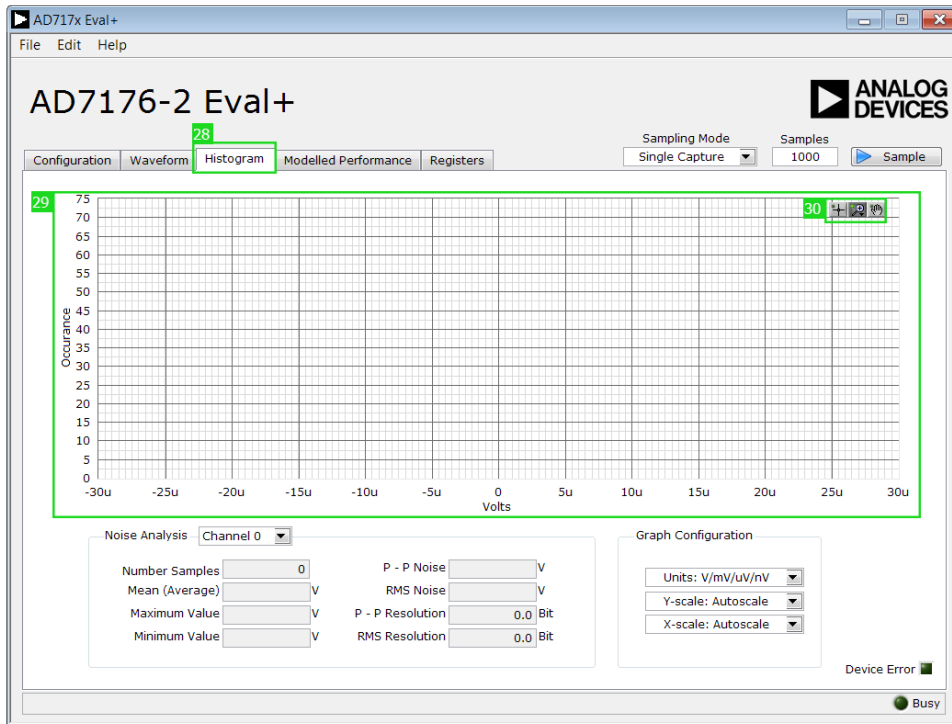

Figure 22. Histogram Tab of the AD7176-2 Evaluation Software

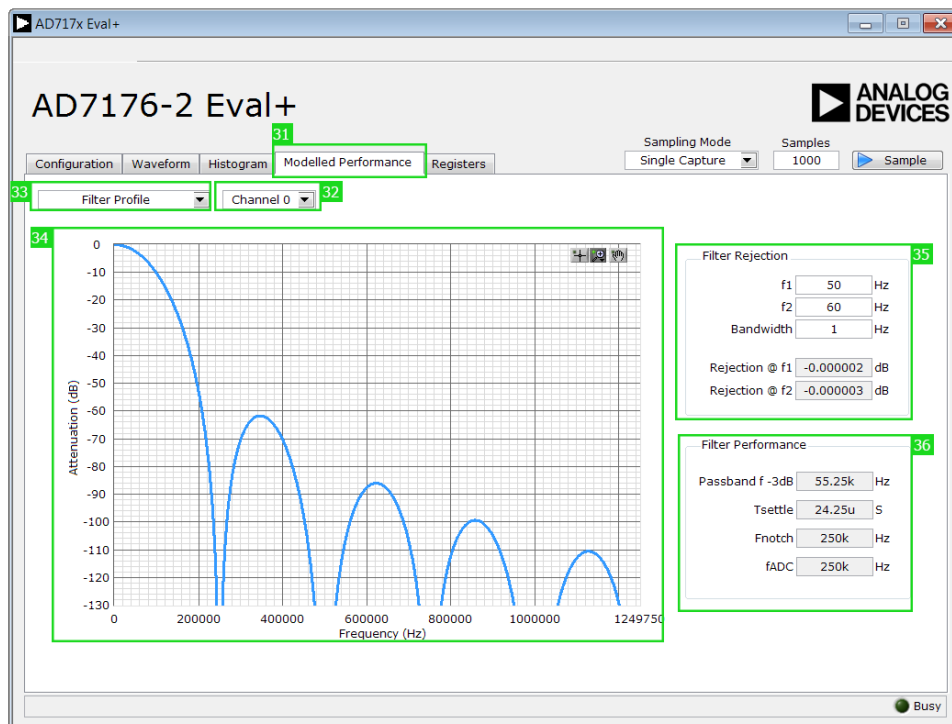

Figure 23. Filter Profile of the AD7176-2 Evaluation Software

MODELLED PERFORMANCE TAB (31)

The **Modelled Performance** (31) tab shows a number of ADC performance parameters, which are calculated using the ADC functional model. There are three main sections to the **Modelled Performance** (31) tab: **Filter Profile** (33), **Filter Step Response** (37) (see Figure 24), and **Timing Diagram / Power** (42) (see

Figure 25). These can be selected using the dropdown menu (33) (see Figure 23).

Analysis Channel (32)

The analysis channel (32) dropdown menu selects the channel to be evaluated by the functional model (see Figure 23).

Filter Profile (33)

This dropdown menu gives the ability to switch between the three sections of the **Modelled Performance** (31) tab. Figure 23 shows the tab when **Filter Profile** (33) is selected.

Filter Profile Graph (34)

This graph shows the frequency response for the selected digital filter. The graph controls give the ability to zoom in on the data. Click the x-axis and y-axis to change the scales on the graph (see Figure 23).

Filter Rejection (35)

This section shows the rejection/attenuation of the digital filter over the **Rejection @ f1** bandwidth and the **Rejection @ f2** bandwidth in decibels. The **f1**, **f2**, and **Bandwidth** values can be changed (see Figure 23).

Filter Performance (36)

This section shows timing information about the data rate of the selected output. The **Filter Performance** (36) shows the ADC initial settling time (**tSettle**), the first frequency notch (**Fnotch**), and the actual sampling frequency (**fADC**) (see Figure 23).

Filter Step Response (37)

This dropdown menu gives the ability to switch between the three sections of the **Modelled Performance** (31) tab (see see Figure 23). Figure 24 shows the tab when **Filter Step Response** (37) is selected.

Step Response Graph (38)

This graph shows how long the filter takes to settle when the voltage is stepped from one voltage to the next. For this analysis, it is assumed the ADC is continuously converting on only one channel (see Figure 24).

Step Configuration (39)

Step Configuration (39) gives the ability to set the **Voltage before Step**, the **Voltage after Step**, and the **Step Position**. **Step Position** is set as a percentage where 0% is $1/fADC$ and 100% is $2/fADC$ (see Figure 24).

Step Response (40)

This section shows timing information about the data rate of the output selected output. The **Step Response** (40) shows the actual sampling frequency, **fADC**, the ADC initial settling time (**tSettle**), and the settling time between conversions, $1/fADC$ (see Figure 24).

Graph Units (41)

Use this control to switch the step response between **Percentages**, **Volts**, and **Codes** (see Figure 24).

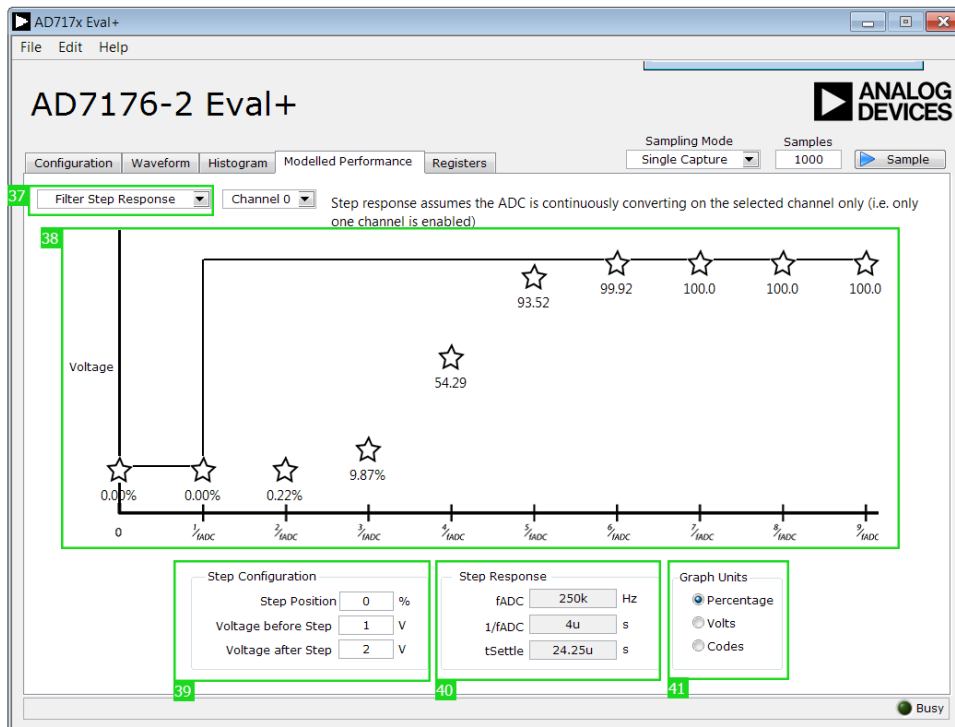

Figure 24. Filter Step Response of the AD7176-2 Evaluation Software

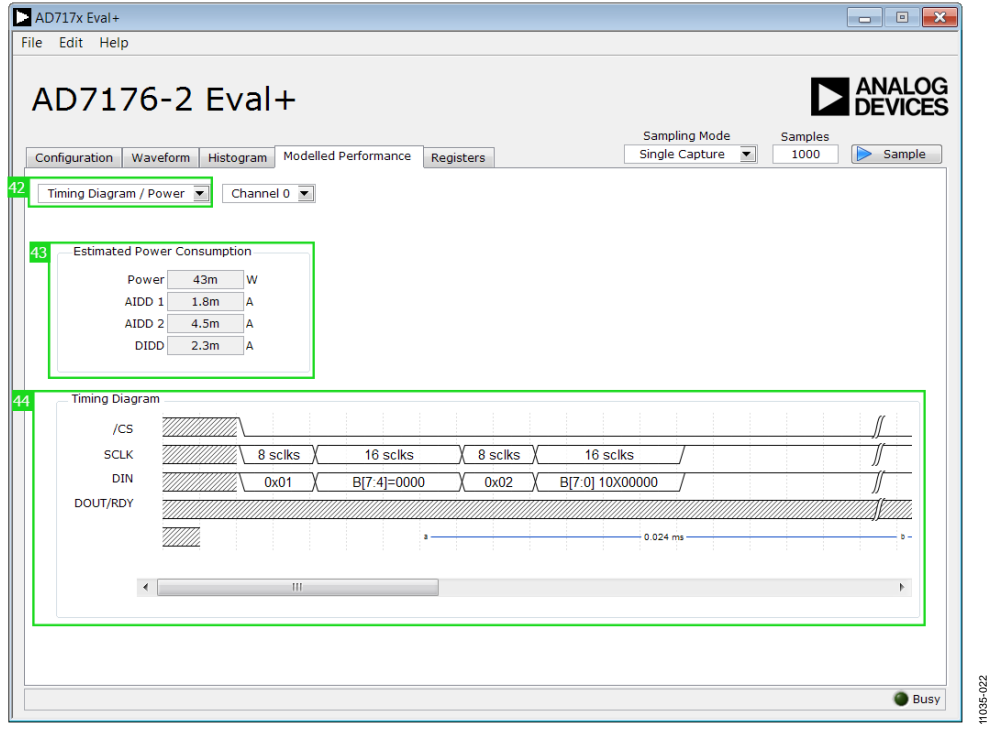

Figure 25. **Timing Diagram / Power** of the **AD7176-2** Evaluation Software

Timing Diagram / Power (42)

This dropdown menu gives the ability to switch between the three sections of the **Modelled Performance** (31) tab. Figure 25 shows the tab when **Timing Diagram / Power** (42) is selected.

Estimated Power Consumption (43)

This section shows the total power consumption of the device in the current configuration as well as the current consumption on each of the power supply rails. Note that the **Estimated**

Power Consumption (43) feature is for continuous conversion mode only, and no other mode of operation is supported (see Figure 25).

Timing Diagram (44)

This graph shows the digital interface **Timing Diagram** (44) for the current configuration. The graph shows the timing for both the configuration of the ADC and the subsequent data reads from the ADC (see Figure 25).

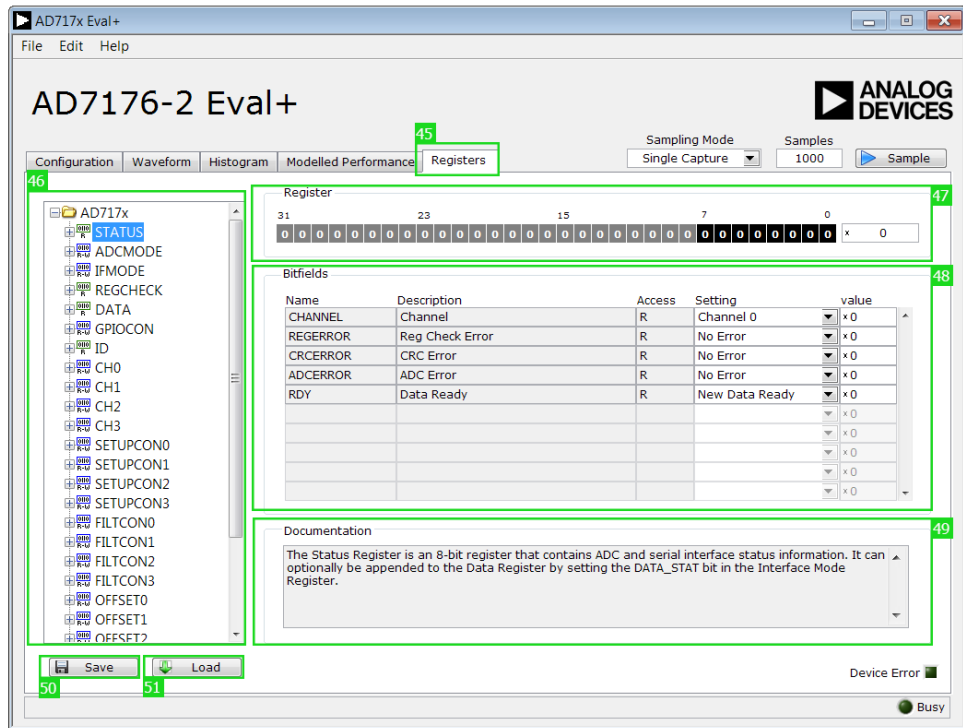

Figure 26. **Registers** Tab of the *AD7176-2* Evaluation Software

REGISTERS TAB (45)

Figure 26 shows the **Registers** (45) tab.

Register Tree (46)

This control shows the full register map in a tree. Each register is shown. Click the expand button next to each register to show all the **Bitfields** (48) contained within that register.

Register (47)

The **Register** (47) control allows you to change the individual bit of the register selected in the register tree (46) by clicking the bits, or by programming the register value directly into the number control field on the right.

Bitfields (48)

This list shows all the **Bitfields** (48) of the register selected in the register tree (46). Change the values by using the dropdown

menu or by directly entering a value into the number control field on the right.

Documentation (49)

The **Documentation** (49) field contains the **Documentation** (49) for the register or bit field selected in the register tree (46).

Save (50) and Load (51)

The **Save** (50) and **Load** (51) buttons allow the user to save the current configuration of the *AD7176-2* by saving off of the register map setting to a file and load the setting from that same file. When using these buttons, the register configurations are saved and loaded as JSON files.

EXITING THE SOFTWARE

To exit the software, click the close button at the top right corner of the *AD717x Eval+* software (see Figure 26).

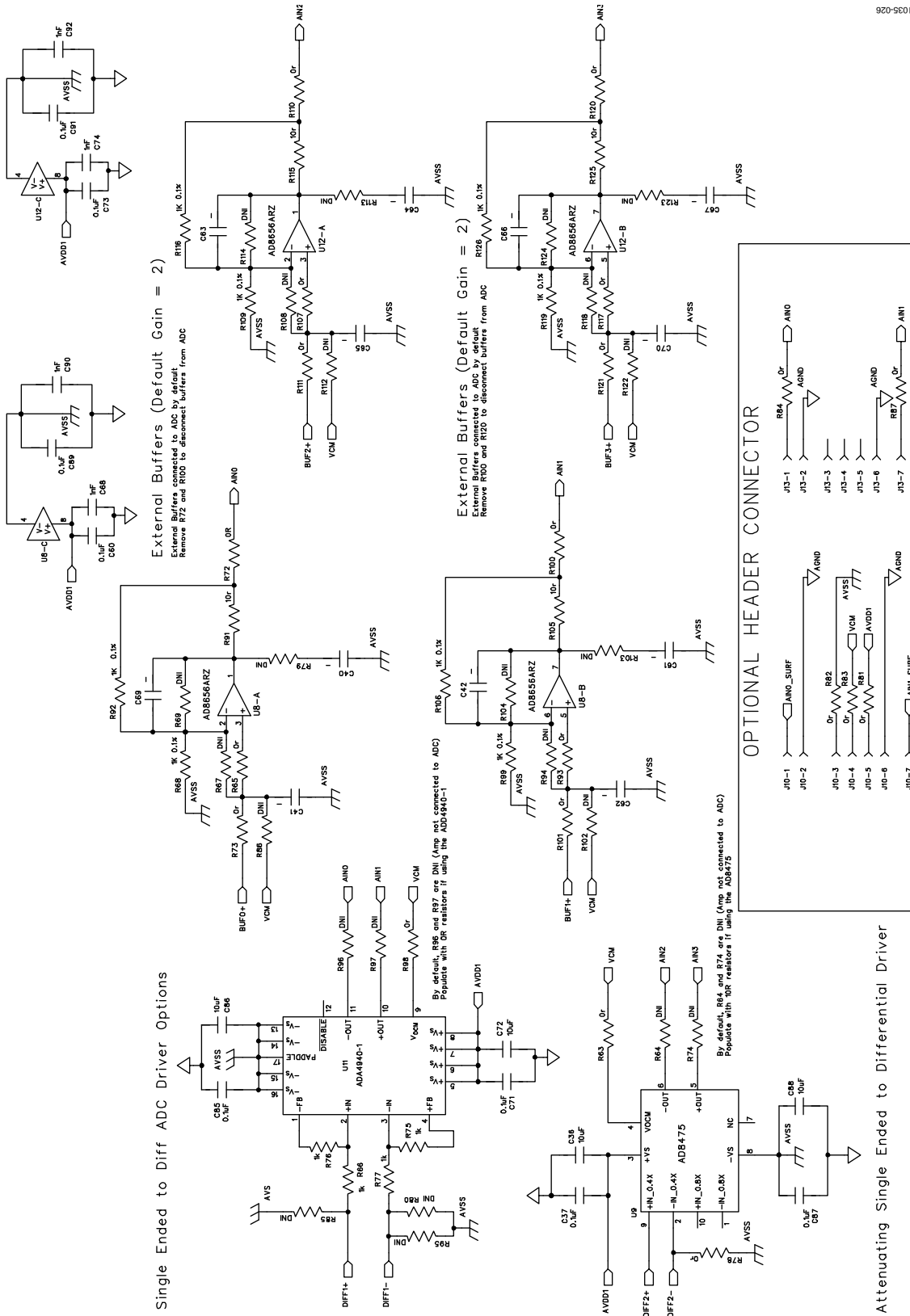

Figure 28. Schematic, Amplifiers

11035-027

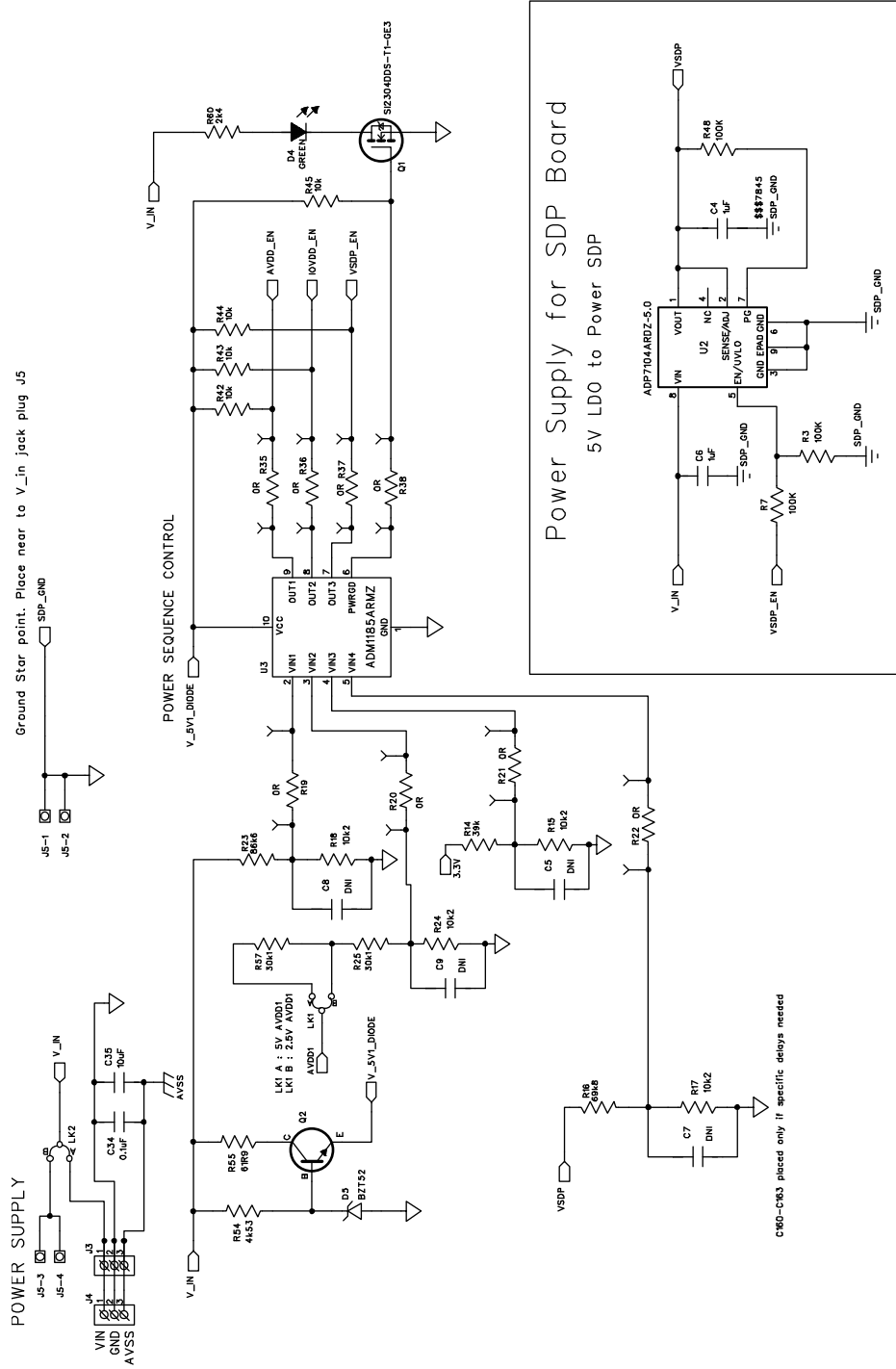

Figure 29. Schematic, Power Supply Sequencing

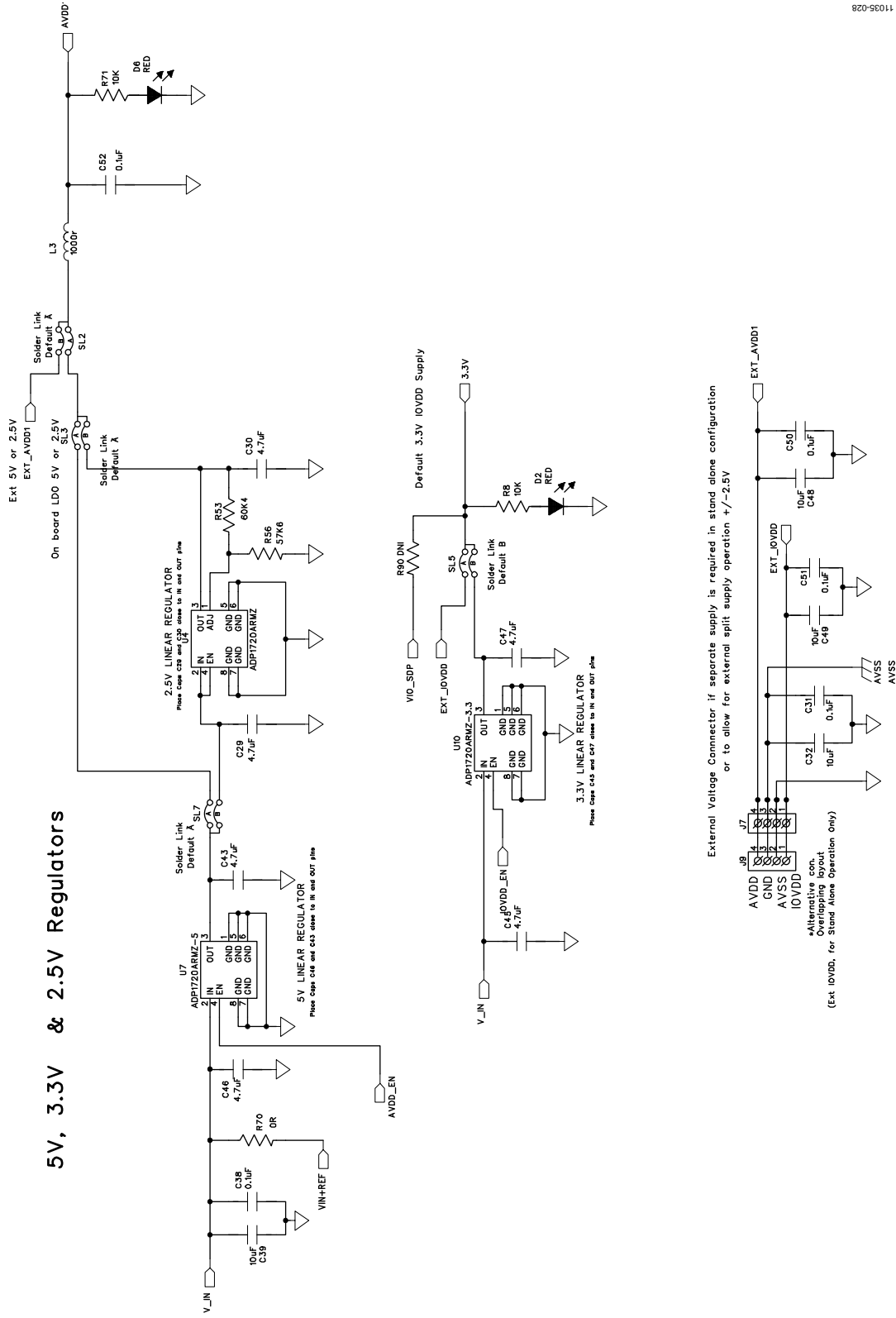

Figure 30. Schematic, Regulators

SDP CONNECTOR EEPROM-SW/USB ID

VIO: USE to set IO voltage max draw 20mA
 VIN: Use this pin to power the SDP requires 4-7V 200mA
 BMODEI: Pull up with a 10K resistor to set SDP to boot from a SPI FLASH on the daughter board

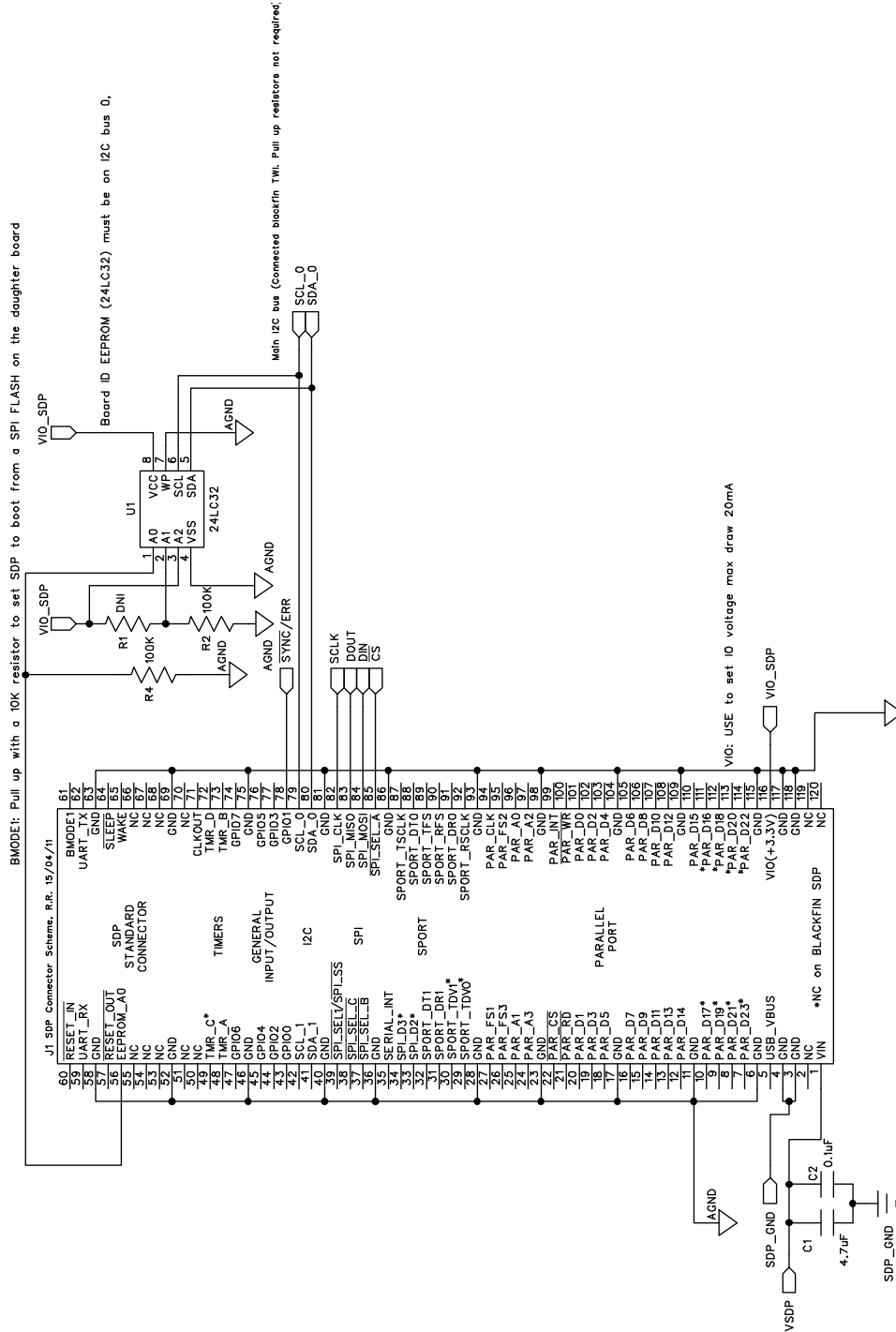
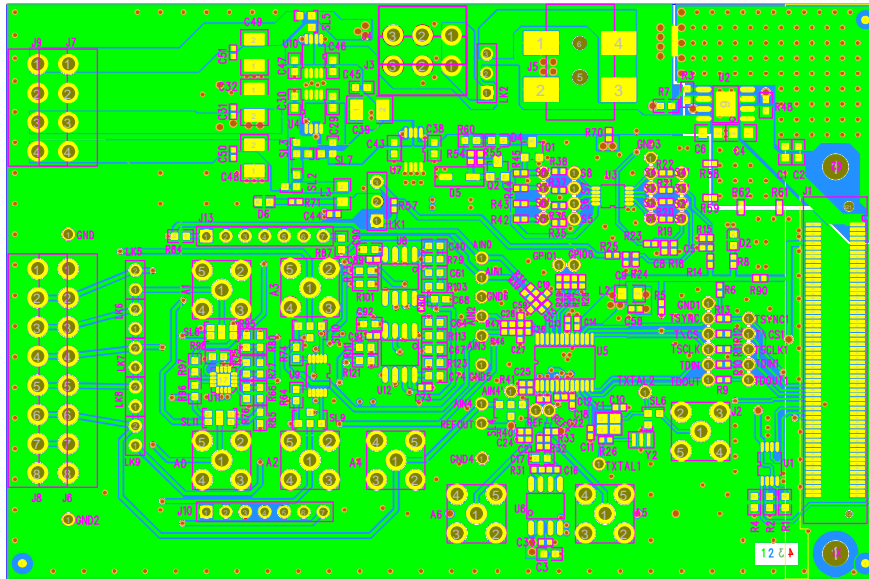

Figure 31. Schematic, SDP Connector

VIN: Use this pin to power the SDP requires 4V 200mA
 I2C bus 1 is connected to the SDP - Pull up resistors required
 (connected to blackfin GPIO - use I2C_0 first)



11035-030

Figure 32. EVAL-AD7176-2SDZ Evaluation Board

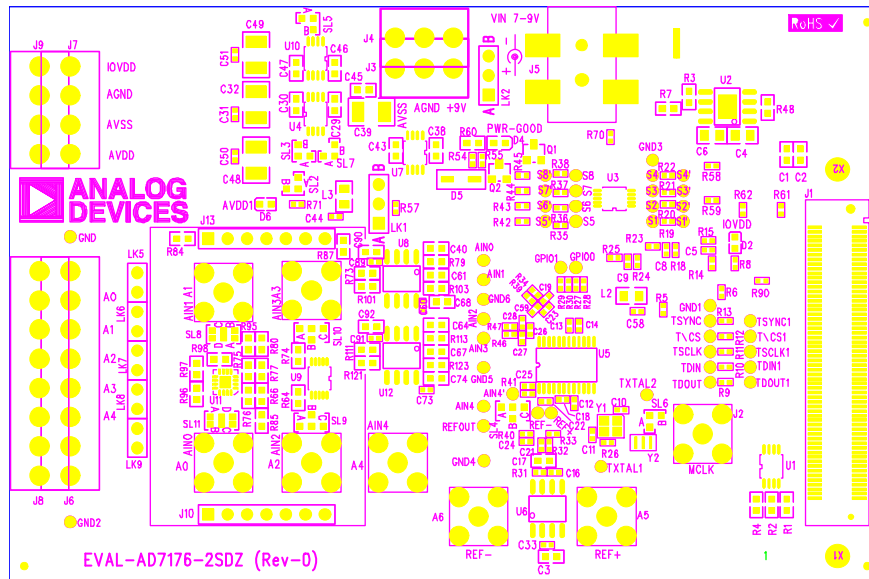

11035-031

Figure 33. Top PCB Silkscreen

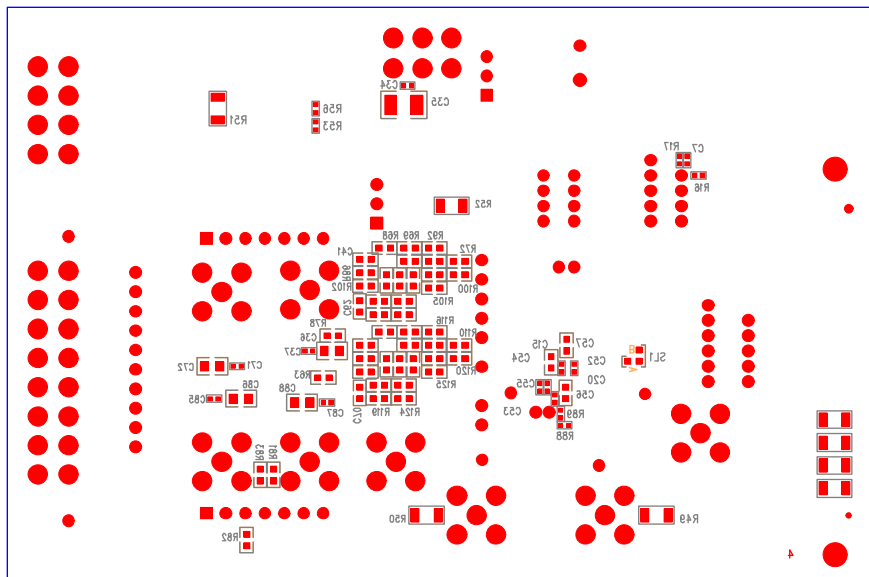

Figure 34. Bottom PCB Silkscreen

11035-032

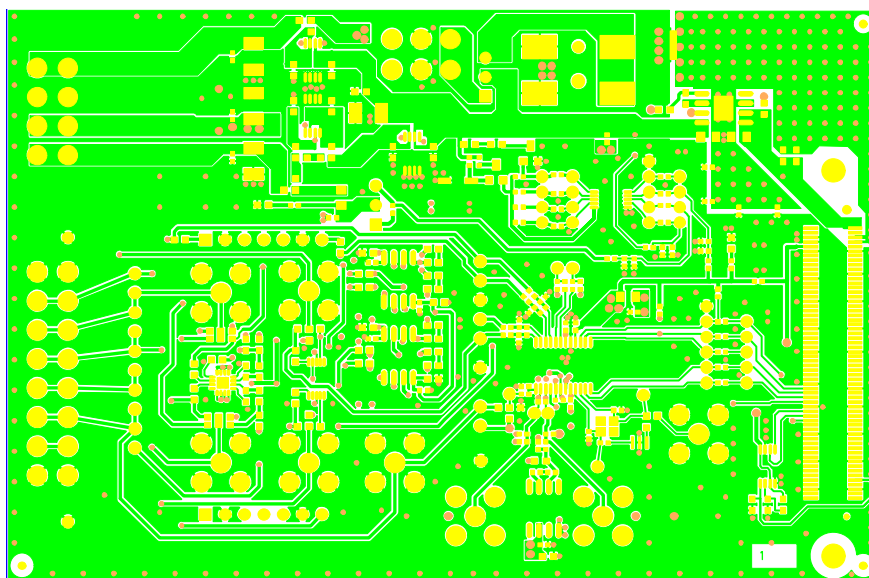
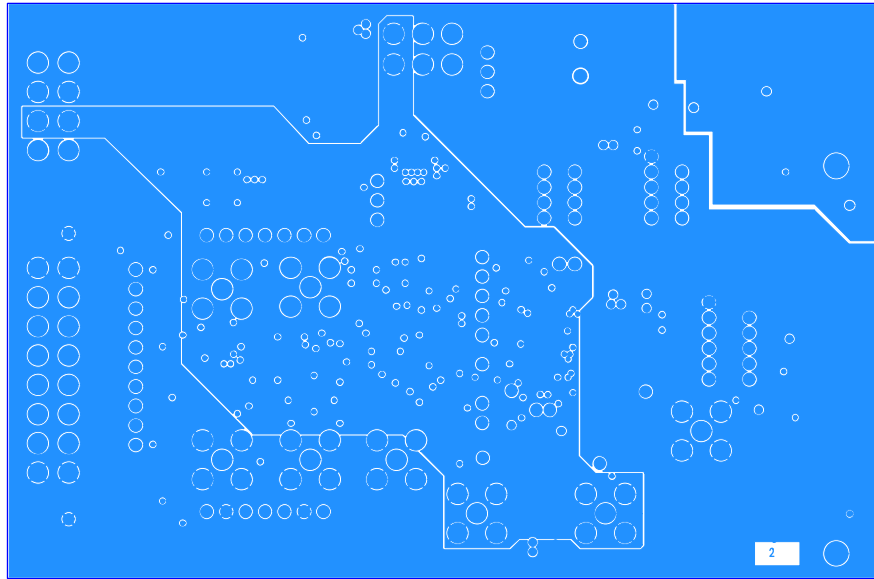

Figure 35. Layer 1 Component Side

11035-033



11035-034

Figure 36. Layer 2 Ground Plane

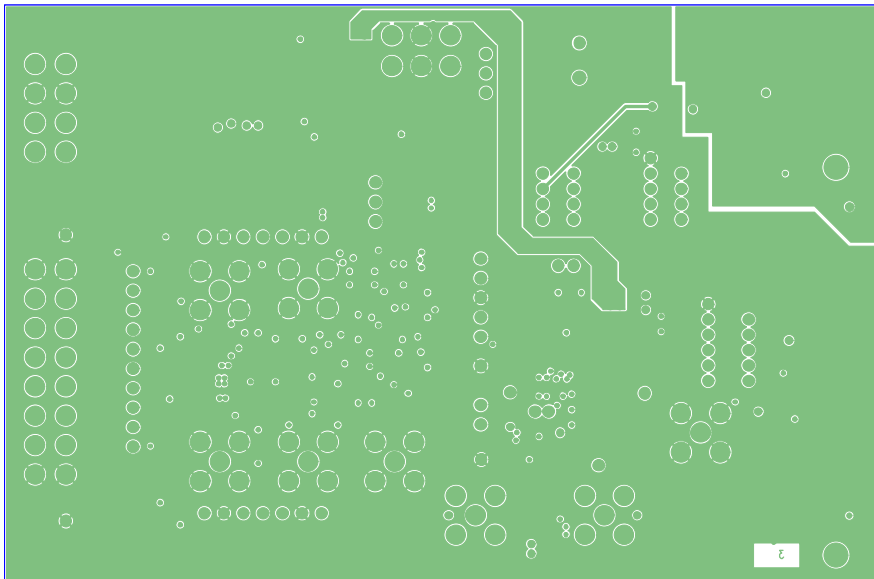

11035-035

Figure 37. Layer 3 Power/Ground Plane

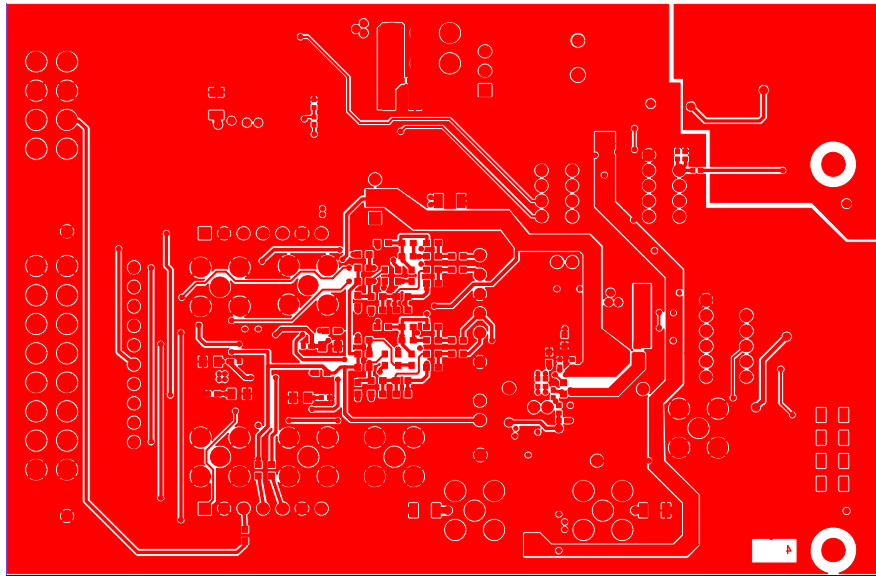

Figure 38. Layer 4 Component Side

ORDERING INFORMATION

BILL OF MATERIALS

In Table 7, the blank cells mean that there is no value specified, N/A means not applicable, and DNI means do not insert.

Table 7.

Name	Value	Tolerance	PCB Decal	Description	Manufacturer	Part No.	Stock Code
A0			SMA	Straight PCB mount SMB jack, keep hole clear of solder	TE Connectivity	1-1337482-0	Do not insert
A1			SMA	Straight PCB mount SMB jack, keep hole clear of solder	TE Connectivity	1-1337482-0	Do not insert
A2			SMA	Straight PCB mount SMB jack, keep hole clear of solder	TE Connectivity	1-1337482-0	Do not insert
A3			SMA	Straight PCB mount SMB jack, keep hole clear of solder	TE Connectivity	1-1337482-0	Do not insert
A4			SMA	Straight PCB mount SMB jack, keep hole clear of solder	TE Connectivity	1-1337482-0	Do not insert
A5			SMA	Straight PCB mount SMB jack, keep hole clear of solder	TE Connectivity	1-1337482-0	Do not insert
A6			SMA	Straight PCB mount SMB jack, keep hole clear of solder	TE Connectivity	1-1337482-0	Do not insert
AIN0			TESTPOINT-SMALL	Test point, not inserted, keep hole clear of solder	N/A	N/A	Do not insert
AIN1			TESTPOINT-SMALL	Test point, not inserted, keep hole clear of solder	N/A	N/A	Do not insert
AIN2			TESTPOINT-SMALL	Test point, not inserted, keep hole clear of solder	N/A	N/A	Do not insert
AIN3			TESTPOINT-SMALL	Test point, not inserted, keep hole clear of solder	N/A	N/A	Do not insert
AIN4			TESTPOINT-SMALL	Test point, not inserted, keep hole clear of solder	N/A	N/A	Do not insert
AIN4'			TESTPOINT-SMALL	Test point, not inserted, keep hole clear of solder	N/A	N/A	Do not insert
C1	4.7 μ F	$\pm 10\%$	C0603	Ceramic capacitor, 6.3 V, X5R, 0603	Murata	GRM188R60J475K	FEC 173-5527
C2	0.1 μ F	$\pm 10\%$	C0603	Ceramic capacitor, 50V, X7R, 0603	Murata	GRM188R71H104K	FEC 882-0023
C3	4.7 μ F	$\pm 10\%$	C0603	Ceramic capacitor, 6.3 V, X7R, 0603	Kemet	C0603C475K8PACTU	FEC 157-2625
C4	1 μ F	$\pm 10\%$	C0805	Ceramic capacitor, 50V, X7R, 0805	Murata	GRM21BR71H105KA12L	FEC 1735541
C5	DNI		C0402	Ceramic capacitor, not inserted, 0402	N/A	N/A	Do not insert
C6	1 μ F	$\pm 10\%$	C0805	Ceramic capacitor, 50V, X7R, 0805	Murata	GRM21BR71H105KA12L	FEC 1735541
C7	DNI		C0402	Ceramic capacitor, not inserted, 0402	N/A	N/A	Do not insert
C8	DNI		C0402	Ceramic capacitor, not inserted, 0402	N/A	N/A	Do not insert
C9	DNI		C0402	Ceramic capacitor, not inserted, 0402	N/A	N/A	Do not insert
C10	DNI		C0402	Ceramic capacitor XTAL, not inserted, 0402	N/A	N/A	Do not insert
C11	DNI		C0402	Ceramic capacitor XTAL, not inserted, 0402	N/A	N/A	Do not insert
C12	0.1 μ F	$\pm 10\%$	C0402	Ceramic capacitor, 16V, X7R, 0402	Murata	GRM155R71C104K	FEC 881-9742
C13	0.1 μ F	$\pm 10\%$	C0402	Ceramic capacitor, 16V, X7R, 0402	Murata	GRM155R71C104K	FEC 881-9742
C14	0.1 μ F	$\pm 10\%$	C0402	Ceramic capacitor, 16V, X7R, 0402	Murata	GRM155R71C104K	FEC 881-9742
C15	1 μ F	$\pm 10\%$	C0603	Ceramic capacitor, 6.3 V, X7R, 0603	Murata	GRM188R70J105KA01D	FEC 184-5765
C16	DNI		C0402	Ceramic capacitor, not inserted, 0402	N/A	N/A	Do not insert

Name	Value	Tolerance	PCB Decal	Description	Manufacturer	Part No.	Stock Code
C17	4.7 μ F	$\pm 10\%$	C0603	Ceramic capacitor, 6.3 V, X5R, 0603	Murata	GRM188R60J475K	FEC 173-5527
C18	0.1 μ F	$\pm 10\%$	C0402	Ceramic capacitor, 16 V, X7R, 0402	Murata	GRM155R71C104K	FEC 881-9742
C19	270 pF	5%	R0402	Ceramic capacitor, 25 V, NP0, 0402			FEC 132-7623
C20	0.1 μ F	$\pm 10\%$	C0402	Ceramic capacitor, 16 V, X7R, 0402	Murata	GRM155R71C104K	FEC 881-9742
C21	0.1 μ F	$\pm 10\%$	C0402	Ceramic capacitor, 16 V, X7R, 0402	Murata	GRM155R71C104K	FEC 881-9742
C22	0.1 μ F	$\pm 10\%$	C0402	Ceramic capacitor, 16 V, X7R, 0402	Murata	GRM155R71C104K	FEC 881-9742
C23	680 pF	$\pm 5\%$	R0402	Ceramic capacitor, 50 V, NP0, 0402	Kemet	C0402C681J5GACTU	FEC 153-5557
C24	DNI		C0402	Ceramic capacitor, not inserted, 0402	N/A	N/A	Do not insert
C25	DNI		C0402	Ceramic capacitor, not inserted, 0402	N/A	N/A	Do not insert
C26	680 pF	$\pm 5\%$	R0402	Ceramic capacitor, 50 V, NP0, 0402	Kemet	C0402C681J5GACTU	FEC 153-5557
C27	270 pF	$\pm 5\%$	R0402	Ceramic capacitor, 25 V, NP0, 0402	AVX	04023A271JAT2A	FEC 132-7623
C28	270 pF	$\pm 5\%$	R0402	Ceramic capacitor, 25 V, NP0, 0402	AVX	04023A271JAT2A	FEC 132-7623
C29	4.7 μ F	$\pm 10\%$	C0603	Ceramic capacitor, 6.3 V, X5R, 0603	Murata	GRM188R60J475K	FEC 173-5527
C30	4.7 μ F	$\pm 10\%$	C0603	Ceramic capacitor, 6.3 V, X5R, 0603	Murata	GRM188R60J475K	FEC 173-5527
C31	0.1 μ F	$\pm 10\%$	C0402	Ceramic capacitor, 16 V, X7R, 0402	Murata	GRM155R71C104K	FEC 881-9742
C32	10 μ F	$\pm 10\%$	1210	Ceramic capacitor, 50 V, X5R, 1210	Murata	GRM32ER61H106K	FEC 184-5764
C33	0.1 μ F	$\pm 10\%$	C0402	Ceramic capacitor, 16 V, X7R, 0402	Murata	GRM155R71C104K	FEC 881-9742
C34	0.1 μ F	$\pm 10\%$	C0402	Ceramic capacitor, 16 V, X7R, 0402	Murata	GRM155R71C104K	FEC 881-9742
C35	10 μ F	$\pm 10\%$	1210	Ceramic capacitor, 50 V, X5R, 1210	Murata	GRM32ER61H106K	FEC 184-5764
C36	10 μ F	$\pm 10\%$	C0805	Ceramic capacitor, 16 V, X5R, 0805	Murata	GRM21BR61C106KE15L	Digi-Key 490-3886-1-ND
C37	0.1 μ F	$\pm 10\%$	C0402	Ceramic capacitor, 16 V, X7R, 0402	Murata	GRM155R71C104K	FEC 881-9742
C38	0.1 μ F	$\pm 10\%$	C0603	Ceramic capacitor, 50 V, X7R, 0603	Murata	GRM188R71H104K	FEC 882-0023
C39	10 μ F	$\pm 10\%$	1210	Ceramic capacitor, 50 V, X5R, 1210	Murata	GRM32ER61H106K	FEC 184-5764
C40			C0603	Ceramic capacitor, not inserted, 0603	N/A	N/A	Do not insert
C41			C0603	Ceramic capacitor, not inserted, 0603	N/A	N/A	Do not insert
C42			C0603	Ceramic capacitor, not inserted, 0603	N/A	N/A	Do not insert
C43	4.7 μ F	$\pm 10\%$	C0603	Ceramic capacitor, 6.3 V, X5R, 0603	Murata	GRM188R60J475K	FEC 173-5527
C44	0.1 μ F	$\pm 10\%$	C0402	Ceramic capacitor, 16 V, X7R, 0402	Murata	GRM155R71C104K	FEC 881-9742
C45	4.7 μ F	$\pm 10\%$	C0603	Ceramic capacitor, 6.3 V, X7R, 0603	Kemet	C0603C475K8PACTU	FEC 157-2625
C46	4.7 μ F	$\pm 10\%$	C0603	Ceramic capacitor, 6.3 V, X7R, 0603	Kemet	C0603C475K8PACTU	FEC 157-2625
C47	4.7 μ F	$\pm 10\%$	C0603	Ceramic capacitor, 6.3 V, X5R, 0603	Murata	GRM188R60J475K	FEC 173-5527
C48	10 μ F	$\pm 10\%$	1210	Ceramic capacitor, 50 V, X5R, 1210	Murata	GRM32ER61H106K	FEC 184-5764

Name	Value	Tolerance	PCB Decal	Description	Manufacturer	Part No.	Stock Code
C49	10 μ F	$\pm 10\%$	1210	Ceramic capacitor, 50V, X5R, 1210	Murata	GRM32ER61H106K	FEC 184-5764
C50	0.1 μ F	$\pm 10\%$	C0402	Ceramic capacitor, 16V, X7R, 0402	Murata	GRM155R71C104K	FEC 881-9742
C51	0.1 μ F	$\pm 10\%$	C0402	Ceramic capacitor, 16V, X7R, 0402	Murata	GRM155R71C104K	FEC 881-9742
C52	0.1 μ F	$\pm 10\%$	C0402	Ceramic capacitor, 16V, X7R, 0402	Murata	GRM155R71C104K	FEC 881-9742
C53	0.1 μ F	$\pm 10\%$	C0402	Ceramic capacitor, 16V, X7R, 0402	Murata	GRM155R71C104K	FEC 881-9742
C54	0.1 μ F	$\pm 10\%$	C0402	Ceramic capacitor, 16V, X7R, 0402	Murata	GRM155R71C104K	FEC 881-9742
C55	0 Ω	$\pm 1\%$	R0402	Resistor, 0402	Vishay	CRCW04020000Z0ED	FEC 146-9661
C56	1 μ F	$\pm 10\%$	C0603	Ceramic capacitor, 6.3 V, X7R, 0603	Murata	GRM188R70J105KA01D	FEC 184-5765
C57	1 μ F	$\pm 10\%$	C0603	Ceramic capacitor, 6.3 V, X7R, 0603	Murata	GRM188R70J105KA01D	FEC 184-5765
C58	0.1 μ F	$\pm 10\%$	C0402	Ceramic capacitor, 16V, X7R, 0402	Murata	GRM155R71C104K	FEC 881-9742
C59	270 pF	$\pm 5\%$	R0402	Ceramic capacitor, 25V, NP0, 0402	AVX	04023A271JAT2A	FEC 132-7623
C60	0.1 μ F	$\pm 10\%$	C0402	Ceramic capacitor, 16V, X7R, 0402	Murata	GRM155R71C104K	FEC 881-9742
C61			C0603	Ceramic capacitor, not inserted, 0603	N/A	N/A	Do not insert
C62			C0603	Ceramic capacitor, not inserted, 0603	N/A	N/A	Do not insert
C63			C0603	Ceramic capacitor, not inserted, 0603	N/A	N/A	Do not insert
C64			C0603	Ceramic capacitor, not inserted, 0603	N/A	N/A	Do not insert
C65			C0603	Ceramic capacitor, not inserted, 0603	N/A	N/A	Do not insert
C66			C0603	Ceramic capacitor, not inserted, 0603	N/A	N/A	Do not insert
C67			C0603	Ceramic capacitor, not inserted, 0603	N/A	N/A	Do not insert
C68	1 nF	$\pm 10\%$	C0603	Ceramic capacitor, 50V, X7R, 0603	Yageo	2238 586 15623	FEC 722170
C69			C0603	Ceramic capacitor, not inserted, 0603	N/A	N/A	Do not insert
C70			C0603	Ceramic capacitor, not inserted, 0603	N/A	N/A	Do not insert
C71	0.1 μ F	$\pm 10\%$	C0402	Ceramic capacitor, 16V, X7R, 0402	Murata	GRM155R71C104K	FEC 881-9742
C72	10 μ F	$\pm 10\%$	C0805	Ceramic capacitor, 16V, X5R, 0805	Murata	GRM21BR61C106KE15L	Digi-Key 490-3886-1-ND
C73	0.1 μ F	$\pm 10\%$	C0402	Ceramic capacitor, 16V, X7R, 0402	Murata	GRM155R71C104K	FEC 881-9742
C74	1 nF	$\pm 10\%$	C0603	Ceramic capacitor, 50V, X7R, 0603	Phycomp	2238 586 15623	FEC 722170
C85	0.1 μ F	$\pm 10\%$	C0402	Ceramic capacitor, 16V, X7R, 0402	Murata	GRM155R71C104K	FEC 881-9742
C86	10 μ F	$\pm 10\%$	C0805	Ceramic capacitor, 16V, X5R, 0805	Murata	GRM21BR61C106KE15L	Digi-Key 490-3886-1-ND
C87	0.1 μ F	$\pm 10\%$	C0402	Ceramic capacitor, 16V, X7R, 0402	Murata	GRM155R71C104K	FEC 881-9742
C88	10 μ F	$\pm 10\%$	C0805	Ceramic capacitor, 16V, X5R, 0805	Murata	GRM21BR61C106KE15L	Digi-Key 490-3886-1-ND
C89	0.1 μ F	$\pm 10\%$	C0402	Ceramic capacitor, 16V, X7R, 0402	Murata	GRM155R71C104K	FEC 881-9742
C90	1 nF	$\pm 10\%$	C0603	Ceramic capacitor, 50V, X7R, 0603	Phycomp	2238 586 15623	FEC 722170
C91	0.1 μ F	$\pm 10\%$	C0402	Ceramic capacitor, 16V, X7R, 0402	Murata	GRM155R71C104K	FEC 881-9742

Name	Value	Tolerance	PCB Decal	Description	Manufacturer	Part No.	Stock Code
C92	1 nF	±10%	C0603	Ceramic capacitor, 50V, X7R, 0603	Phycomp	2238 586 15623	FEC 722170
D2	Red		LED-0603HSML-C191	Red LED, high intensity 90 mCd, 0603	Avago Technologies	HSMC-C191	FEC 855-4528
D4	Green		LED-0603	Green LED, surface-mount device, 0603	OSRAM	LGQ971	Digi-Key 475-1409-1-ND
D5	BZT52		SOD-123	Zener diode, 0.5 W, 5.1 V	Vishay	BZT52B5V1-V-G508	FEC 1617767
D6	Red		LED-0603HSML-C191	Red LED, high intensity 90 mCd, 0603	Avago Technologies	HSMC-C191	FEC 855-4528
GND			TESTPOINT-SMALL	Test point, not inserted, keep hole clear of solder	N/A	N/A	Do not insert
GND1			TESTPOINT-SMALL	Test point, not inserted, keep hole clear of solder	N/A	N/A	Do not insert
GND2			TESTPOINT-SMALL	Test point, not inserted, keep hole clear of solder	N/A	N/A	Do not insert
GND3			TESTPOINT-SMALL	Test point, not inserted, keep hole clear of solder	N/A	N/A	Do not insert
GND4			TESTPOINT-SMALL	Test point, not inserted, keep hole clear of solder	N/A	N/A	Do not insert
GND5			TESTPOINT-SMALL	Test point, not inserted, keep hole clear of solder	N/A	N/A	Do not insert
GND6			TESTPOINT-SMALL	Test point, not inserted, keep hole clear of solder	N/A	N/A	Do not insert
GPIO0			TESTPOINT-SMALL	Test point, not inserted, keep hole clear of solder	N/A	N/A	Do not insert
GPIO1			TESTPOINT-SMALL	Test point, not inserted, keep hole clear of solder	N/A	N/A	Do not insert
J1			CON-120/FX8-120S-SV	120-way connector, 0.6 mm pitch	Hirose	FX8-120S-SV(21)	FEC 1324660
J2			SMB	Straight PCB mount SMB jack, keep hole clear of solder	TE Connectivity	1-1337482-0	Do not insert
J3			CON\POWE R3(3_81 PITCH)	Socket terminal block, pitch 3.81 mm	Phoenix Contact	MC 1,5/ 5-G-3,81	FEC 370-4737
J4			CON\POWE R3(3_81 PITCH)	Screw terminal block, pitch 3.81 mm	Phoenix Contact	1727023	Do not insert
J5			CON\BARR EL_SMD_2 MM_KLDX-SMT2-0202-A	DC power connectors, 2 mm SMT power jack	Kycon	KLDX-SMT2-0202-A	Mouser 806-KLDX-SMT20202A
J6			CON\POWE R8(3_81 PITCH)	8-pin terminal header, pitch 3.81 mm, vertical	Phoenix Contact	MC 1,5/ 8-G-3,81	FEC 3704774
J7	1 × 4-pin		CON\POWE R4(3_81 PITCH)	Connector, pitch 3.81 mm, right angle	Phoenix Contact	MC 1,5/ 4-G-3,81 and 180-3594	Do not insert
J8			CON\POWE R8(3_81 PITCH)	8-pin terminal header, pitch 3.81 mm, vertical	Phoenix Contact	1727078	Do not insert
J9	1 × 4-pin		CON\POWE R4(381 PITCH)	Screw terminal block, pitch 3.81 mm	Phoenix Contact	1727036	FEC 370-4592
J10			SIP-7P	7-way, receptacle connector, 2.54 mm vertical socket	Samtec	SSW-107-01-T-S	FEC 1803478
J13			SIP-7P	7-way, header connector, 2.54 mm through hole header	Samtec	TLW-107-05-G-S	FEC 1668499
L2	1000 Ω		805	Ferrite bead, 0.3 Ω at dc, 1000 Ω at 100 MHz, 350 mA, 0805	TE Connectivity	BMB2A1000LN2	FEC 119-3421
L3	1000 Ω		805	Ferrite bead, 0.3 Ω at dc, 1000 Ω at 100 MHz, 350 mA, 0805	TE Connectivity	BMB2A1000LN2	FEC 119-3421

Name	Value	Tolerance	PCB Decal	Description	Manufacturer	Part No.	Stock Code
LK1			LINK-3P_TEXT_INV	3-pin (3 × 1), 0.1 in. (2.54 mm) pitch header and shorting block in A	Harwin	M20-9990346 and M7566-05	FEC 1022249 and 150-411
LK2			LINK-3P	3-pin (3 × 1), 0.1 in. (2.54 mm) pitch header and shorting block in A	Harwin	M20-9990346 and M7566-05	FEC 1022249 and 150-411
LK5			SIP-2P	2-pin, 0.1 in. pitch header and shorting shunt	Harwin	M20-9990246	FEC 1022247 and 150-411
LK6			SIP-2P	2-pin, 0.1 in. pitch header and shorting shunt	Harwin	M20-9990246	FEC 1022247 and 150-411
LK7			SIP-2P	2-pin, 0.1 in. pitch header and shorting shunt	Harwin	M20-9990246	FEC 1022247 and 150-411
LK8			SIP-2P	2-pin, 0.1 in. pitch header and shorting shunt	Harwin	M20-9990246	FEC 1022247 and 150-411
LK9			SIP-2P	2-pin, 0.1 in. pitch header and shorting shunt	Harwin	M20-9990246	FEC 1022247 and 150-411
Q1			SOT-23	Metal-oxide-semiconductor field-effect transistor	Vishay Siliconix	SI2304DDS-T1-GE3	FEC 1858939
Q2			SOT-23	General-purpose NPN silicon transistor	ON Semiconductor	MMBT3904LT1G	FEC 1459100
R1	DNI	±1%	R0603	Resistor, not inserted, 0603	N/A	N/A	Do not insert
R2	100 kΩ	±1%	R0603	Surface-mount device resistor	Multicomp	MC 0.063W 0603 1% 100K	FEC 9330402
R3	100 kΩ	±1%	R0603	Surface-mount device resistor	Multicomp	MC 0.063W 0603 1% 100K	FEC 9330402
R4	100 kΩ	±1%	R0603	Surface-mount device resistor	Multicomp	MC 0.063W 0603 1% 100K	FEC 9330402
R5	10 kΩ	±1%	R0402	Resistor, 0402	Vishay	CRCW040210K0FKEAHP	FEC 173-8864
R6	10 kΩ	±1%	R0402	Resistor, 0402	Vishay	CRCW040210K0FKEAHP	FEC 173-8864
R7	100 kΩ	±1%	R0603	Surface-mount device resistor	Multicomp	MC 0.063W 0603 1% 100K	FEC 9330402
R8	10 kΩ	±1%	R0402	Resistor, 0402	Phycomp	CRCW040210K0FKEAHP	FEC 173-8864
R9	0 Ω	±1%	R0402	Resistor, 0402	Vishay	CRCW04020000Z0ED	FEC 146-9661
R10	0 Ω	±1%	R0402	Resistor, 0402	Vishay	CRCW04020000Z0ED	FEC 146-9661
R11	0 Ω	±1%	R0402	Resistor, 0402	Vishay	CRCW04020000Z0ED	FEC 146-9661
R12	0 Ω	±1%	R0402	Resistor, 0402	Vishay	CRCW04020000Z0ED	FEC 146-9661
R13	0 Ω	±1%	R0402	Resistor, 0402	Vishay	CRCW04020000Z0ED	FEC 146-9661
R14	39 kΩ	±1%	R0402	Resistor, 0402	Multicomp	MC 0.0625W 0402 1% 69K8	FEC 1358085
R15	10.2 kΩ	±1%	R0402	Surface-mount device resistor	Multicomp	MC 0.0625W 0402 1% 10K2	FEC 1803137
R16	69.8 kΩ	±1%	R0402	Resistor, 0402	Multicomp	MC 0.0625W 0402 1% 69K8	FEC 1803735
R17	10.2 kΩ	±1%	R0402	Surface-mount device resistor	Multicomp	MC 0.0625W 0402 1% 10K2	FEC 1803137
R18	10.2 kΩ	±1%	R0402	Surface-mount device resistor	Multicomp	MC 0.0625W 0402 1% 10K2	FEC 1803137
R19	0 Ω	±1%	R0402	Resistor, 0402	Vishay	CRCW04020000Z0ED	FEC 146-9661
R20	0 Ω	±1%	R0402	Resistor, 0402	Vishay	CRCW04020000Z0ED	FEC 146-9661
R21	0 Ω	±1%	R0402	Resistor, 0402	Vishay	CRCW04020000Z0ED	FEC 146-9661
R22	0 Ω	±1%	R0402	Resistor, 0402	Vishay	CRCW04020000Z0ED	FEC 146-9661
R23	86.6 kΩ	±1%	R0402	Resistor, 0402	Multicomp	MC 0.0625W 0402 1% 86K6	FEC 1803744
R24	10.2 kΩ	±1%	R0402	Surface-mount device resistor	Multicomp	MC 0.0625W 0402 1% 10K2	FEC 1803137
R25	30.1 kΩ	±1%	R0402	Resistor, 0402	Multicomp	MC 0.0625W 0402 1% 30k1	FEC 1803699
R26	DNI	±1%	R0402	Resistor, 0402	Vishay	CRCW04020000Z0ED	Do not insert
R27	0 Ω	±1%	R0402	Resistor, 0402	Vishay	CRCW04020000Z0ED	FEC 146-9661
R28	DNI	±1%	R0402	Resistor, not inserted, 0402	N/A	N/A	Do not insert
R29	DNI	±1%	R0402	Resistor, not inserted, 0402	N/A	N/A	Do not insert
R30	0 Ω	±1%	R0402	Resistor, 0402	Vishay	CRCW04020000Z0ED	FEC 146-9661
R31	DNI	±1%	R0402	Resistor, not inserted, 0402	N/A	N/A	Do not insert
R32	0 Ω	±1%	R0402	Resistor, 0402	Vishay	CRCW04020000Z0ED	FEC 146-9661
R33	DNI	±1%	R0402	Resistor, not inserted, 0402	Vishay	CRCW04020000Z0ED	Do not insert
R34	0 Ω	±1%	R0402	Resistor, 0402	Vishay	CRCW04020000Z0ED	FEC 146-9661
R35	0 Ω	±1%	R0402	Resistor, 0402	Vishay	CRCW04020000Z0ED	FEC 146-9661
R36	0 Ω	±1%	R0402	Resistor, 0402	Vishay	CRCW04020000Z0ED	FEC 146-9661
R37	0 Ω	±1%	R0402	Resistor, 0402	Vishay	CRCW04020000Z0ED	FEC 146-9661
R38	0 Ω	±1%	R0402	Resistor, 0402	Vishay	CRCW04020000Z0ED	FEC 146-9661
R39	0 Ω	±1%	R0402	Resistor, 0402	Vishay	CRCW04020000Z0ED	FEC 146-9661
R40	0 Ω	±1%	R0402	Resistor, 0402	Vishay	CRCW04020000Z0ED	FEC 146-9661
R41	0 Ω	±1%	R0402	Resistor, 0402	Vishay	CRCW04020000Z0ED	FEC 146-9661

Name	Value	Tolerance	PCB Decal	Description	Manufacturer	Part No.	Stock Code
R42	10 kΩ	±5%	R0402	Resistor, thick film	Yageo	RC0402JR-1310KL	FEC 179-9316
R43	10 kΩ	±5%	R0402	Resistor, thick film	Yageo	RC0402JR-1310KL	FEC 179-9316
R44	10 kΩ	±5%	R0402	Resistor, thick film	Yageo	RC0402JR-1310KL	FEC 179-9316
R45	10 kΩ	±5%	R0402	Resistor, thick film	Yageo	RC0402JR-1310KL	FEC 179-9316
R46	0 Ω	±1%	R0402	Resistor, 0402	Vishay	CRCW04020000Z0ED	FEC 146-9661
R47	0 Ω	±1%	R0402	Resistor, 0402	Vishay	CRCW04020000Z0ED	FEC 146-9661
R48	100 kΩ	±1%	R0603	Surface-mount device resistor	Multicomp	MC 0.063W 0603 1% 100K	FEC 9330402
R49	0 Ω	±1%	1206	Resistor, 1206	Multicomp	MC 0.125W 1206 0R	FEC 9336974
R50	0 Ω	±1%	1206	Resistor, 1206	Multicomp	MC 0.125W 1206 0R	FEC 9336974
R51	0 Ω	±1%	1206	Resistor, 1206	Multicomp	MC 0.125W 1206 0R	FEC 9336974
R52	0 Ω	±1%	1206	Resistor, 1206	Multicomp	MC 0.125W 1206 0R	FEC 9336974
R53	60.4 kΩ	±1%	R0402	Resistor, 0402	Multicomp	MC 0.0625W 0402 1% 60K4	FEC 1803729
R54	4.53 kΩ	±1%	R0402	Resistor, thick film	Vishay	CRCW04024K53FKED	FEC 1151244
R55	61.9 Ω	±1%	R0402	Resistor, 0402	Multicomp	MC 0.0625W 0402 1% 61R9	FEC 1802915
R60	2.4 kΩ	±1%	R0603	Resistor, thick film	Yageo	RC0603FR-072K4L	FEC 1799329
R61	0 Ω	±1%	R0402	Resistor, 0402	Vishay	CRCW04020000Z0ED	FEC 146-9661
R62	0 Ω	±1%	R0402	Resistor, 0402	Vishay	CRCW04020000Z0ED	FEC 146-9661
R63	0 Ω	±1%	R0603	Resistor, 0603	Vishay	CRCW06030000Z0EA	FEC 146-9739
R64	DNI	±1%	R0603	Resistor, not inserted, 0603	Vishay	CRCW06030000Z0EA	Do not insert
R65	0 Ω	±1%	R0603	Resistor, 0603	Vishay	CRCW06030000Z0EA	FEC 146-9739
R66	1 kΩ	±1%	R0603	Resistor, thick film, 0603	Vishay	CRCW06031K00FKEA	FEC 1469740
R67	DNI	±1%	R0603	Resistor, not inserted, 0603	Vishay	CRCW06030000Z0EA	Do not insert
R68	1 kΩ	±0.1%	R0603	Resistor, 0603	Panasonic	ERA3AEB102V	FEC 157-7605
R69	DNI	±1%	R0603	Resistor, not inserted, 0603	N/A	N/A	Do not insert
R70	0 Ω	±1%	R0402	Resistor, 0402	Vishay	CRCW04020000Z0ED	FEC 146-9661
R71	10 kΩ	±1%	R0402	Resistor, 0402	Vishay	CRCW040210K0FKEAHP	FEC 173-8864
R72	0 Ω	±1%	R0603	Resistor, 0603	Vishay	CRCW06030000Z0EA	FEC 146-9739
R73	0 Ω	±1%	R0603	Resistor, 0603	Vishay	CRCW06030000Z0EA	FEC 146-9739
R74	DNI	±1%	R0603	Resistor, not inserted, 0603	Vishay	CRCW06030000Z0EA	Do not insert
R75	1 kΩ	±1%	R0603	Resistor, thick film, 0603	Vishay	CRCW06031K00FKEA	FEC 1469740
R76	1 kΩ	±1%	R0603	Resistor, thick film, 0603	Vishay	CRCW06031K00FKEA	FEC 1469740
R77	1 kΩ	±1%	R0603	Resistor, thick film, 0603	Vishay	CRCW06031K00FKEA	FEC 1469740
R78	0 Ω	±1%	R0603	Resistor, 0603	Vishay	CRCW06030000Z0EA	FEC 146-9739
R79	DNI	±1%	R0603	Resistor, not inserted, 0603	Vishay	CRCW06030000Z0EA	Do not insert
R80	DNI	±1%	R0603	Resistor, not inserted, 0603	Vishay	CRCW06030000Z0EA	Do not insert
R81	0 Ω	±1%	R0603	Resistor, 0603	Vishay	CRCW06030000Z0EA	FEC 146-9739
R82	0 Ω	±1%	R0603	Resistor, 0603	Vishay	CRCW06030000Z0EA	FEC 146-9739
R83	0 Ω	±1%	R0603	Resistor, 0603	Vishay	CRCW06030000Z0EA	FEC 146-9739
R84	0 Ω	±1%	R0603	Resistor, 0603	Vishay	CRCW06030000Z0EA	FEC 146-9739
R85	DNI	±1%	R0603	Resistor, not inserted, 0603	Vishay	CRCW06030000Z0EA	Do not insert
R86	DNI	±1%	R0603	Resistor, not inserted, 0603	Vishay	CRCW06030000Z0EA	Do not insert
R87	0 Ω	±1%	R0603	Resistor, 0603	Vishay	CRCW06030000Z0EA	FEC 146-9739
R88	1 kΩ	±1%	R0204	Resistor, 0402	Multicomp	MC 0.0625W 0402 1% 1K	FEC 135-8043
R89	1 kΩ	±1%	R0204	Resistor, 0402	Multicomp	MC 0.0625W 0402 1% 1K	FEC 135-8043
R90	DNI	±1%	R0402	Resistor, 0402	Vishay	CRCW04020000Z0ED	Do not insert
R91	10 Ω	±1%	R0603	Resistor, 0603	Bourns	CR0603-FX-10R0GLF	FEC 200-8331
R92	1 kΩ	±0.1%	R0603	Resistor, 0603	Panasonic	ERA3AEB102V	FEC 157-7605
R93	0 Ω	±1%	R0603	Resistor, 0603	Vishay	CRCW06030000Z0EA	FEC 146-9739
R94	DNI	±1%	R0603	Resistor, not inserted, 0603	Vishay	CRCW06030000Z0EA	Do not insert
R95	DNI	±1%	R0603	Resistor, not inserted, 0603	Vishay	CRCW06030000Z0EA	Do not insert
R96	DNI	±1%	R0603	Resistor, not inserted, 0603	Vishay	CRCW06030000Z0EA	Do not insert
R97	DNI	±1%	R0603	Resistor, not inserted, 0603	Vishay	CRCW06030000Z0EA	Do not insert
R98	0 Ω	±1%	R0603	Resistor, 0603	Vishay	CRCW06030000Z0EA	FEC 146-9739
R99	1 kΩ	±0.1%	R0603	Resistor, 0603	Panasonic	ERA3AEB102V	FEC 157-7605
R100	0 Ω	±1%	R0603	Resistor, 0603	Vishay	CRCW06030000Z0EA	FEC 146-9739
R101	0 Ω	±1%	R0603	Resistor, 0603	Vishay	CRCW06030000Z0EA	FEC 146-9739
R102	DNI	±1%	R0603	Resistor, not inserted, 0603	Vishay	CRCW06030000Z0EA	Do not insert
R103	DNI	±1%	R0603	Resistor, not inserted, 0603	Vishay	CRCW06030000Z0EA	Do not insert
R104	DNI	±1%	R0603	Resistor, not inserted, 0603	N/A	N/A	Do not insert

Name	Value	Tolerance	PCB Decal	Description	Manufacturer	Part No.	Stock Code
R105	10 Ω	$\pm 1\%$	R0603	Resistor, 0603	Bourns	CR0603-FX-10R0GLF	FEC 200-8331
R106	1 k Ω	$\pm 0.1\%$	R0603	Resistor, 0603	Panasonic	ERA3AEB102V	FEC 157-7605
R107	0 Ω	$\pm 1\%$	R0603	Resistor, 0603	Vishay	CRCW06030000Z0EA	FEC 146-9739
R108	DNI	$\pm 1\%$	R0603	Resistor, not inserted, 0603	Vishay	CRCW06030000Z0EA	Do not insert
R109	1 k Ω	$\pm 0.1\%$	R0603	Resistor, 0603	Panasonic	ERA3AEB102V	FEC 157-7605
R110	0 Ω	$\pm 1\%$	R0603	Resistor, 0603	Vishay	CRCW06030000Z0EA	FEC 146-9739
R111	0 Ω	$\pm 1\%$	R0603	Resistor, 0603	Vishay	CRCW06030000Z0EA	FEC 146-9739
R112	DNI	$\pm 1\%$	R0603	Resistor, not inserted, 0603	Vishay	CRCW06030000Z0EA	Do not insert
R113	DNI	$\pm 1\%$	R0603	Resistor, not inserted, 0603	Vishay	CRCW06030000Z0EA	Do not insert
R114	DNI	$\pm 1\%$	R0603	Resistor, not inserted, 0603	N/A	N/A	Do not insert
R115	10 Ω	$\pm 1\%$	R0603	Resistor, 0603	Bourns	CR0603-FX-10R0GLF	FEC 200-8331
R116	1 k Ω	$\pm 0.1\%$	R0603	Resistor, 0603	Panasonic	ERA3AEB102V	FEC 157-7605
R117	0 Ω	$\pm 1\%$	R0603	Resistor, 0603	Vishay	CRCW06030000Z0EA	FEC 146-9739
R118	DNI	$\pm 1\%$	R0603	Resistor, not inserted, 0603	Vishay	CRCW06030000Z0EA	Do not insert
R119	1 k Ω	$\pm 0.1\%$	R0603	Resistor, 0603	Panasonic	ERA3AEB102V	FEC 157-7605
R120	0 Ω	$\pm 1\%$	R0603	Resistor, 0603	Vishay	CRCW06030000Z0EA	FEC 146-9739
R121	0 Ω	0.01	R0603	Resistor, 0603	Vishay	CRCW06030000Z0EA	FEC 146-9739
R122	DNI	0.01	R0603	Resistor, not inserted, 0603	Vishay	CRCW06030000Z0EA	Do not insert
R123	DNI	0.01	R0603	Resistor, not inserted, 0603	Vishay	CRCW06030000Z0EA	Do not insert
R124	DNI	0.01	R0603	Resistor, not inserted, 0603	N/A	N/A	Do not insert
R125	10 Ω	$\pm 1\%$	R0603	Resistor, 0603	Bourns	CR0603-FX-10R0GLF	FEC 200-8331
R126	1 k Ω	$\pm 0.1\%$	R0603	Resistor, 0603	Panasonic	ERA3AEB102V	FEC 157-7605
REF+			TESTPOINT-SMALL	Test point, not inserted, keep hole clear of solder	N/A	N/A	Do not insert
REF-			TESTPOINT-SMALL	Test point, not inserted, keep hole clear of solder	N/A	N/A	Do not insert
REFOUT			TESTPOINT-SMALL	Test point, not inserted, keep hole clear of solder	N/A	N/A	Do not insert
SL1			0603-2WAY-BRIDGE	2-way solder link (use 0 Ω , 0603 resistor), insert in Link Position A	N/A		FEC 933-1662
SL2			0603-2WAY-BRIDGE	2-way solder link (use 0 Ω , 0603 resistor), insert in Link Position A	N/A		FEC 933-1662
SL3			0603-2WAY-BRIDGE	2-way solder link (use 0 Ω , 0603 resistor), insert in Link Position A	N/A		FEC 933-1662
SL4			0603-3WAY-BRIDGE	3-way solder link (use 0 Ω , 0603 resistor), insert in Link Position A	N/A		FEC 933-1662
SL5			0603-2WAY-BRIDGE	2-way solder link (use 0 Ω , 0603 resistor), insert in Link Position B	N/A		FEC 933-1662
SL6			0603-2WAY-BRIDGE	2-way solder link (use 0 Ω , 0603 resistor)	N/A		Do not insert
SL7			0603-3WAY-BRIDGE	3-way solder link (use 0 Ω , 0603 resistor), insert in Link Position A	N/A		FEC 933-1662
SL8			0603-4WAY-BRIDGE	4-way solder link (use 0 Ω , 0603 resistor), insert in Link Position B			FEC 933-1662
SL9			0603-3WAY-BRIDGE	3-way solder link (use 0 Ω , 0603 resistor), insert in Link Position B	N/A		FEC 933-1662
SL10			0603-3WAY-BRIDGE	3-way solder link (use 0 Ω , 0603 resistor), insert in Link Position B	N/A		FEC 933-1662
SL11			0603-4WAY-BRIDGE	4-way solder link (use 0 Ω , 0603 resistor), insert in Link Position B			FEC 933-1662
STAR3			COMPONENT LINKAA	Ground link	N/A	N/A	N/A

Name	Value	Tolerance	PCB Decal	Description	Manufacturer	Part No.	Stock Code
TDIN			TESTPOINT-SMALL	Test point, not inserted, keep hole clear of solder	N/A	N/A	Do not insert
TDIN1			TESTPOINT-SMALL	Test point, not inserted, keep hole clear of solder	N/A	N/A	Do not insert
TDOUT			TESTPOINT-SMALL	Test point, not inserted, keep hole clear of solder	N/A	N/A	Do not insert
TDOUT1			TESTPOINT-SMALL	Test point, not inserted, keep hole clear of solder	N/A	N/A	Do not insert
TSCLK			TESTPOINT-SMALL	Test point, not inserted, keep hole clear of solder	N/A	N/A	Do not insert
TSCLK1			TESTPOINT-SMALL	Test point, not inserted, keep hole clear of solder	N/A	N/A	Do not insert
TSYNC			TESTPOINT-SMALL	Test point, not inserted, keep hole clear of solder	N/A	N/A	Do not insert
TSYNC1			TESTPOINT-SMALL	Test point, not inserted, keep hole clear of solder	N/A	N/A	Do not insert
TXTAL1			TESTPOINT-SMALL	Test point, not inserted, keep hole clear of solder	N/A	N/A	Do not insert
TXTAL2			TESTPOINT-SMALL	Test point, not inserted, keep hole clear of solder	N/A	N/A	Do not insert
TVCS			TESTPOINT-SMALL	Test point, not inserted, keep hole clear of solder	N/A	N/A	Do not insert
TVCS1			TESTPOINT-SMALL	Test point, not inserted, keep hole clear of solder	N/A	N/A	Do not insert
U1			MSO8	32k I ² C serial electrically erasable programmable read-only memory	Microchip	24LC32A-I/MS	FEC1331330
U2			SO8NB_RD8-2	Linear regulator 5 V, 20 V, 500 mA, ultralow noise	Analog Devices	ADP7104ARDZ-5.0	ADP7104ARDZ-5.0
U3			MSO10	Quad voltage monitor and sequencer	Analog Devices	ADM1185ARMZ-1	ADM1185ARMZ-1
U4			MSO8	50 mA, high voltage, micro-power linear regulator, adjustable	Analog Devices	ADP1720ARMZ-R7	ADP1720ARMZ-R7
U5			TSSOP24	2-/4-channel, 250 kSPS, 24-bit, multiplexed Σ - Δ ADC	Analog Devices	AD7176-2BRUZ	AD7176-2BRUZ
U6			SO8NB	5 V eXtra implanted junction field-effect transistor (FET) reference (XFET [®])	Analog Devices	ADR445BRZ	ADR445BRZ
U7			MSO8	50 mA, high voltage, micro-power linear regulator, 5 V	Analog Devices	ADP1720ARMZ-5-R7	ADP1720ARMZ-5-R7
U8			SO8NB	Dual op amp	Analog Devices	AD8656ARZ	AD8656ARZ
U9			MSO10	Fully differential funnel amplifier	Analog Devices	AD8475ARMZ	AD8475ARMZ
U10			MSO8	50 mA, high voltage, micro-power linear regulator, 3.3 V	Analog Devices	ADP1720ARMZ-3.3-R7	ADP1720ARMZ-3.3-R7
U11			LFCSP-16-3MM	Ultralow power, low distortion ADC driver	Analog Devices	ADA4940-1ACPZ	ADA4940-1ACPZ
U12			SO8NB	Dual op amp	Analog Devices	AD8656ARZ	AD8656ARZ
V1			R1206	1206 place holder	N/A	N/A	Do not insert
V2			R1206	1206 place holder	N/A	N/A	Do not insert
V3			R1206	1206 place holder	N/A	N/A	Do not insert
V4			R1206	1206 place holder	N/A	N/A	Do not insert
Y1	16 MHz		XTAL-FA20H	Miniature crystal, surface-mount device	Epson Toyocom	FA-20H, 16 MHz, 10 PPM, 9 PF	FEC 171-2814

NOTES

**ESD Caution**

ESD (electrostatic discharge) sensitive device. Charged devices and circuit boards can discharge without detection. Although this product features patented or proprietary protection circuitry, damage may occur on devices subjected to high energy ESD. Therefore, proper ESD precautions should be taken to avoid performance degradation or loss of functionality.

Legal Terms and Conditions

By using the evaluation board discussed herein (together with any tools, components documentation or support materials, the "Evaluation Board"), you are agreeing to be bound by the terms and conditions set forth below ("Agreement") unless you have purchased the Evaluation Board, in which case the Analog Devices Standard Terms and Conditions of Sale shall govern. Do not use the Evaluation Board until you have read and agreed to the Agreement. Your use of the Evaluation Board shall signify your acceptance of the Agreement. This Agreement is made by and between you ("Customer") and Analog Devices, Inc. ("ADI"), with its principal place of business at One Technology Way, Norwood, MA 02062, USA. Subject to the terms and conditions of the Agreement, ADI hereby grants to Customer a free, limited, personal, temporary, non-exclusive, non-sublicensable, non-transferable license to use the Evaluation Board FOR EVALUATION PURPOSES ONLY. Customer understands and agrees that the Evaluation Board is provided for the sole and exclusive purpose referenced above, and agrees not to use the Evaluation Board for any other purpose. Furthermore, the license granted is expressly made subject to the following additional limitations: Customer shall not (i) rent, lease, display, sell, transfer, assign, sublicense, or distribute the Evaluation Board; and (ii) permit any Third Party to access the Evaluation Board. As used herein, the term "Third Party" includes any entity other than ADI, Customer, their employees, affiliates and in-house consultants. The Evaluation Board is NOT sold to Customer; all rights not expressly granted herein, including ownership of the Evaluation Board, are reserved by ADI. CONFIDENTIALITY. This Agreement and the Evaluation Board shall all be considered the confidential and proprietary information of ADI. Customer may not disclose or transfer any portion of the Evaluation Board to any other party for any reason. Upon discontinuation of use of the Evaluation Board or termination of this Agreement, Customer agrees to promptly return the Evaluation Board to ADI. ADDITIONAL RESTRICTIONS. Customer may not disassemble, decompile or reverse engineer chips on the Evaluation Board. Customer shall inform ADI of any occurred damages or any modifications or alterations it makes to the Evaluation Board, including but not limited to soldering or any other activity that affects the material content of the Evaluation Board. Modifications to the Evaluation Board must comply with applicable law, including but not limited to the RoHS Directive. TERMINATION. ADI may terminate this Agreement at any time upon giving written notice to Customer. Customer agrees to return to ADI the Evaluation Board at that time. LIMITATION OF LIABILITY. THE EVALUATION BOARD PROVIDED HEREUNDER IS PROVIDED "AS IS" AND ADI MAKES NO WARRANTIES OR REPRESENTATIONS OF ANY KIND WITH RESPECT TO IT. ADI SPECIFICALLY DISCLAIMS ANY REPRESENTATIONS, ENDORSEMENTS, GUARANTEES, OR WARRANTIES, EXPRESS OR IMPLIED, RELATED TO THE EVALUATION BOARD INCLUDING, BUT NOT LIMITED TO, THE IMPLIED WARRANTY OF MERCHANTABILITY, TITLE, FITNESS FOR A PARTICULAR PURPOSE OR NON-INFRINGEMENT OF INTELLECTUAL PROPERTY RIGHTS. IN NO EVENT WILL ADI AND ITS LICENSORS BE LIABLE FOR ANY INCIDENTAL, SPECIAL, INDIRECT, OR CONSEQUENTIAL DAMAGES RESULTING FROM CUSTOMER'S POSSESSION OR USE OF THE EVALUATION BOARD, INCLUDING BUT NOT LIMITED TO LOST PROFITS, DELAY COSTS, LABOR COSTS OR LOSS OF GOODWILL. ADI'S TOTAL LIABILITY FROM ANY AND ALL CAUSES SHALL BE LIMITED TO THE AMOUNT OF ONE HUNDRED US DOLLARS (\$100.00). EXPORT. Customer agrees that it will not directly or indirectly export the Evaluation Board to another country, and that it will comply with all applicable United States federal laws and regulations relating to exports. GOVERNING LAW. This Agreement shall be governed by and construed in accordance with the substantive laws of the Commonwealth of Massachusetts (excluding conflict of law rules). Any legal action regarding this Agreement will be heard in the state or federal courts having jurisdiction in Suffolk County, Massachusetts, and Customer hereby submits to the personal jurisdiction and venue of such courts. The United Nations Convention on Contracts for the International Sale of Goods shall not apply to this Agreement and is expressly disclaimed.