

INSULATED GATE BIPOLAR TRANSISTOR

$V_{CES} = 1200V$ $I_{C(Nominal)} = 110A$ $T_{J(max)} = 175^{\circ}C$ $V_{CE(on)} typ = 1.7V @ I_C = 110A$

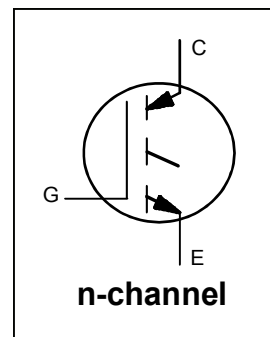

Applications

- Industrial Motor Drives
- UPS
- HEV Inverter
- Welding

G	C	E
Gate	Collector	Emitter

Features	Benefits
Low $V_{CE(on)}$ Trench IGBT Technology	High Efficiency in a Wide Range of Applications
Low Switching Losses	Suitable for a Wide Range of Switching Frequencies
Very Soft Turn-off Characteristics	Reduced EMI and Overvoltage in Motor Drive Applications
10 μ s Short Circuit SOA	Rugged Transient Performance for Increased Reliability
Square RBSOA	
Tight Parameter Distribution	Excellent Current Sharing in Parallel Operation
Positive $V_{CE(on)}$ Temperature Coefficient	
$T_j(max) = 175^{\circ}C$	Increased Reliability

Base part number	Package Type	Standard Pack		Orderable part number
		Form	Quantity	
IRG8CH106K10F	Die on Film	Wafer	1	IRG8CH106K10F

Mechanical Parameter

Die Size	7.5 x 14.1	mm ²
Minimum Street Width	95	μ m
Emitter Pad Size	See Die Drawing	mm ²
Gate Pad Size	1.2 x 1.2	
Area Total / Active	106 / 75	
Thickness	140	μ m
Wafer Size	200	mm
Notch Position	0	Degrees
Maximum-Possible Chips per Wafer	245 pcs.	
Passivation Front side	Silicon Nitride, Polyimide	
Front Metal	Al, Si (5.6 μ m)	
Backside Metal	Al, Ti, Ni, Ag	
Die Bond	Electrically conductive epoxy or solder	
Reject Ink Dot Size	0.25 mm diameter minimum	

Maximum Ratings

	Parameter	Max.	Units
V_{CE}	Collector-Emitter Voltage, $T_J=25^\circ\text{C}$	1200	V
I_C	DC Collector Current	①	A
I_{LM}	Clamped Inductive Load Current ②	330	A
V_{GE}	Gate Emitter Voltage	± 30	V
T_J, T_{STG}	Operating Junction and Storage Temperature	-40 to +175	$^\circ\text{C}$

Static Characteristics (Tested on wafers) @ $T_J=25^\circ\text{C}$

	Parameter	Min.	Typ.	Max.	Units	Conditions
$V_{(BR)CES}$	Collector-to-Emitter Breakdown Voltage	1200	—	—	V	$V_{GE} = 0\text{V}, I_C = 250\mu\text{A}$ ③
$V_{CE(sat)}$	Collector-to-Emitter Saturated Voltage	—	—	2.0		$V_{GE} = 15\text{V}, I_C = 110\text{A}, T_J = 25^\circ\text{C}$ ④
$V_{GE(th)}$	Gate-Emitter Threshold Voltage	5.0	—	6.5		$I_C = 4.0\text{mA}, V_{GE} = V_{CE}$
I_{CES}	Zero Gate Voltage Collector Current	—	1.0	35	μA	$V_{CE} = 1200\text{V}, V_{GE} = 0\text{V}$
I_{GES}	Gate Emitter Leakage Current	—	—	± 600	nA	$V_{CE} = 0\text{V}, V_{GE} = \pm 30\text{V}$
$R_{G\text{ INTERNAL}}$	Internal Gate Resistance	1.6	2.0	2.4	Ω	

Electrical Characteristics (Not subject to production test- Verified by design/characterization)

	Parameter	Min.	Typ.	Max.	Units	Conditions
$V_{CE(sat)}$	Collector-to-Emitter Saturated Voltage	—	1.7	—	V	$V_{GE} = 15\text{V}, I_C = 110\text{A}, T_J = 25^\circ\text{C}$ ⑤
		—	2.1	—		$V_{GE} = 15\text{V}, I_C = 110\text{A}, T_J = 175^\circ\text{C}$ ⑤
SCSOA	Short Circuit Safe Operating Area	10	—	—	μs	$V_{GE} = 15\text{V}, V_{CC} = 600\text{V}$ $V_P \leq 1200\text{V}, T_J = 150^\circ\text{C}$
RBSOA	Reverse Bias Safe Operating Area	FULL SQUARE				$T_J = 175^\circ\text{C}, I_C = 330\text{A}$ $V_{CC} = 960\text{V}, V_P \leq 1200\text{V}$ $V_{GE} = +20\text{V to } 0\text{V}$
C_{iss}	Input Capacitance	—	11550	—	pF	$V_{GE} = 0\text{V}$
C_{oss}	Output Capacitance	—	450	—		$V_{CE} = 30\text{V}$
C_{rss}	Reverse Transfer Capacitance	—	340	—		$f = 1.0\text{MHz}$
Q_g	Total Gate Charge (turn-on)	—	700	—	nC	$I_C = 110\text{A}$ ⑤
Q_{ge}	Gate-to-Emitter Charge (turn-on)	—	40	—		$V_{GE} = 15\text{V}$
Q_{gc}	Gate-to-Collector Charge (turn-on)	—	410	—		$V_{CC} = 600\text{V}$

Switching Characteristics (Inductive Load-Not subject to production test-Verified by design/characterization)

	Parameter	Min.	Typ.	Max.	Units	Conditions ⑥
$t_{d(on)}$	Turn-On delay time	—	80	—	ns	$I_C = 110\text{A}, V_{CC} = 600\text{V}$ $R_G = 1.0\Omega, V_{GE} = 15\text{V}$ $T_J = 25^\circ\text{C}$
t_r	Rise time	—	30	—		
$t_{d(off)}$	Turn-Off delay time	—	380	—		
t_f	Fall time	—	110	—		
$t_{d(on)}$	Turn-On delay time	—	80	—		$I_C = 110\text{A}, V_{CC} = 600\text{V}$ $R_G = 1.0\Omega, V_{GE} = 15\text{V}$ $T_J = 150^\circ\text{C}$
t_r	Rise time	—	30	—		
$t_{d(off)}$	Turn-Off delay time	—	470	—		
t_f	Fall time	—	310	—		

Notes:

- ① The current in the application is limited by T_{JMax} and the thermal properties of the assembly.
- ② $V_{CC} = 80\% (V_{CES}), V_{GE} = 20\text{V}$.
- ③ Refer to AN-1086 for guidelines for measuring $V_{(BR)CES}$ safely.
- ④ Actual test limits take into account additional losses in the measurement setup.
- ⑤ Pulse width $\leq 400\mu\text{s}$; duty cycle $\leq 2\%$.
- ⑥ Values influenced by parasitic L and C in measurement.

Die Drawing

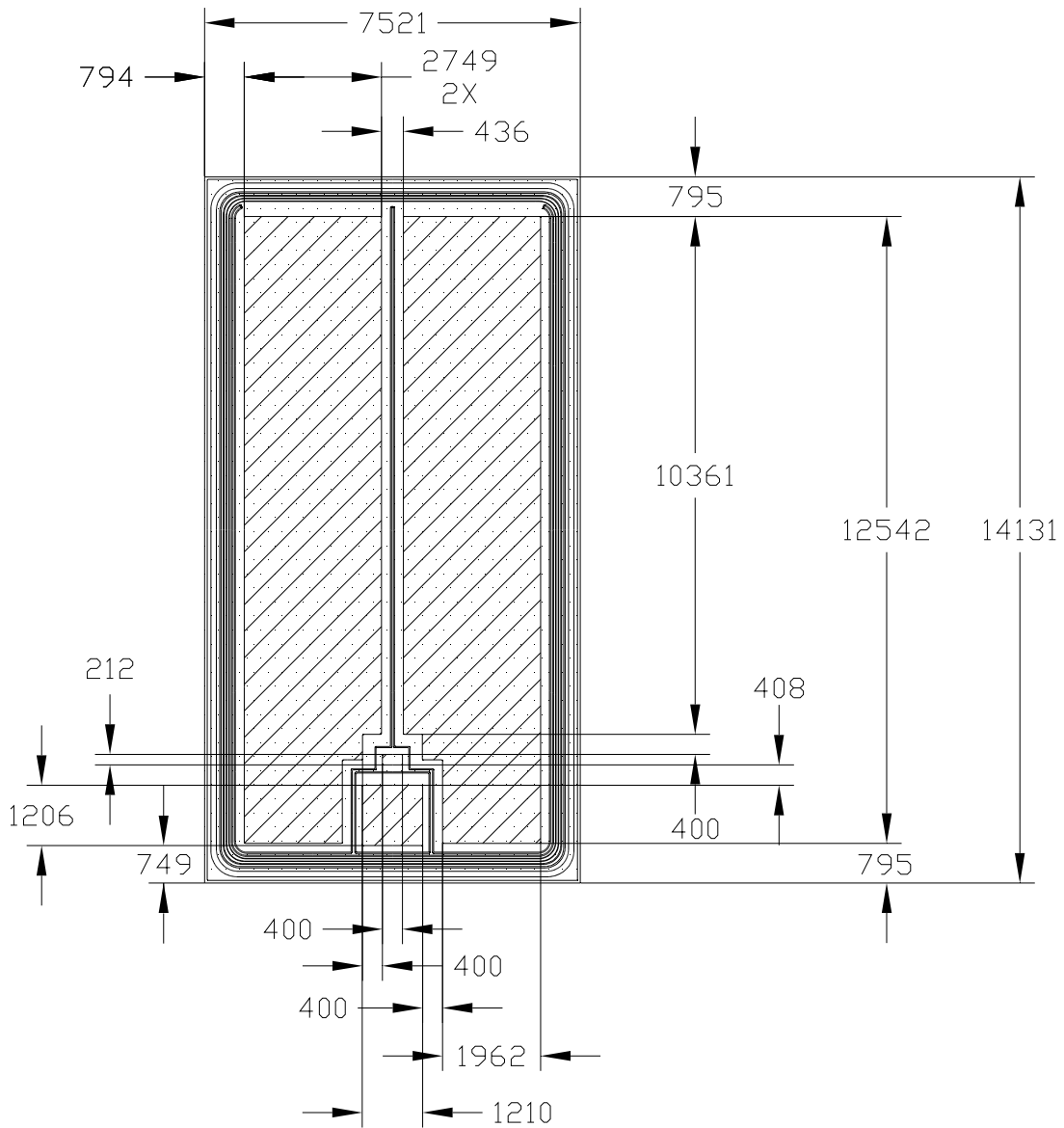

NOTES:

1. ALL DIMENSIONS ARE SHOWN IN MICRO-METER
2. CONTROLLING DIMENSION: MICRO-METER
3. DIE WIDTH AND LENGTH TOLERANCE: $-50\mu\text{m}$
4. DIE THICKNESS = 140 MICRO-METER

Additional Testing and Screening

For Customers requiring product supplied as Known Good Die (KGD) or requiring specific die level testing, please contact your local IR Sales

Shipping

Sawn Wafer on Film. Please contact your local IR sales office for non-standard shipping options

Handling

- Product must be handled only at ESD safe workstations. Standard ESD precautions and safe work environments are as defined in MIL-HDBK-263.
- Product must be handled only in a class 10,000 or better-designated clean room environment.
- Singulated die are not to be handled with tweezers. A vacuum wand with a non-metallic ESD protected tip should be used.

Wafer/Die Storage

- Proper storage conditions are necessary to prevent product contamination and/or degradation after shipment.
- Note: To reduce the risk of contamination or degradation, it is recommended that product not being used in the assembly process be returned to their original containers and resealed with a vacuum seal process.
- Sawn wafers on a film frame are intended for immediate use and have a limited shelf life.

Further Information

For further information please contact your local IR Sales office.

Revision History

Date	Comments
06/04/2015	<ul style="list-style-type: none"> • Updated IFX logo on page 1 & 4.



IR WORLD HEADQUARTERS: 101 N. Sepulveda Blvd., El Segundo, California 90245, USA
 To contact International Rectifier, please visit <http://www.irf.com/whoto-call/>