



Ha-VIS RFID RF-R400 Reader

## Advantages

- Applicable in rough, metal-containing industrial environments
- Robust aluminium housing
- High transponder population
- Very fast multiplexing speed
- Robust M12 and M8 connectors

## General description

The Ha-VIS RF-R400 is a powerful 4 port UHF RFID reader. With the robust M12 (Ethernet) and M8 (power, IO and serial) connectors the reader is designed for the harsh industrial and railway environment. Even in time critical applications multiple antennas could be used due to its internal high speed multiplexer.

## Technical characteristics

<b>Transponder protocol</b>	EPC Class 1 Gen 2 (ISO 18 000-6-c on request) EPC Class 1 Gen V2
<b>UHF RFID antenna interface</b>	
Antenna connection	4 x SMA connector (50 Ohm); Reader internally multiplexed
Output power	max. 2 W (configurable)
Frequency area	860 MHz ... 928 MHz (depending on specific reader)
<b>Interfaces</b>	
	<ul style="list-style-type: none"> <li>• Ethernet (TCP/IP) 10/100 Mbit/s; Full Spec. 802.3</li> <li>• RS 232</li> <li>• USB</li> </ul>
Inputs	<ul style="list-style-type: none"> <li>• 2 optocoupler (max. 24 V DC / 20 mA)</li> </ul>
Outputs	<ul style="list-style-type: none"> <li>• 2 optocoupler (24 V DC / 20 mA)</li> <li>• 2 relays (24 V DC / 1 A)</li> </ul>

## Technical characteristics

### LED Diagnosis

- 8 LEDs (from left to right)
- Run
  - Host communication
  - Warning
  - Input / output
  - Antenna 1
  - Antenna 2
  - Antenna 3
  - Antenna 4

### Performance

- Bulk-reading capability < 150 Transponder / s
- Max. reading distance up to 16 meters, depending on kind of transponder & environmental conditions

### Protocol modi

- Host Mode
- Scan Mode
- Notification Mode
- Buffered Read Mode

### Power supply

- Power supply + 24 V DC (± 5 %)
- Current consumption max. 3.8 A
- typ. 1 A (without the power consumption of an external connected active device at the antenna ports)

### Design features

- Material of housing Aluminium, powder coated
- Dimensions (W x H x D) 259.8 x 157.3 x 68 mm
- Weight 1.8 kg
- Degree of protection acc. to DIN 60 529 IP 53  
IP 54 (with optional IP54 Protection Set)
- Installation on DIN rail DIN rail mounting kit (optional accessories)

### Environmental conditions

- Operating temperature -40 °C ... +70 °C\*
- Storage temperature -25 °C ... +85 °C
- Relative humidity 5 % ... 95 % (non-condensing)
- Vibration EN 60 068-2-6  
10 Hz ... 150 Hz: 0.075 mm / 1 g
- Shock EN 60 068-2-27  
Acceleration: 30 g

All data given are in line with the actual state of art and therefore not binding.  
HARTING reserves the right to modify designs without giving the relevant reasons.

\* tested according to EN 60068-2-2



Ha-VIS RFID RF-R400 Reader

## Technical characteristics

### Norms & safety

Radio license

- EN 302 208
- FCC 47 FCR Part 15
- IC RSS-GEN, RSS-210

EMC EN 301 489

Low voltage EN 60 950

Human Exposure EN 50 364

RoHS compliant

### Others

- RSSI
- Action on EPC
- Configuration cloning

### Software

Demo- and configuration software

- Ha-VIS RFID config
- Windows® 7 (32 / 64 Bit) or Windows® 10
- Hard disk with minimum free 30 MB memory space
- Ha-VIS Middleware

## Technical characteristics

### Railway (rolling stock)

Isolation EN 50 155

EMC EN 50 121-3-2

EMC EN 50 121-4

Vibration EN 61 373 Cat 1B

Shock EN 61 373 Cat 1B

Wet heat (cyclic) EN 50 155 / EN 60 068-2-30

Fire protection EN 45 545

Upper and lower voltage EN 50 155

Power supply interruption EN 50 155, classes S1 and C1

Power supply overvoltage EN 50 155

Voltage fluctuation EN 50 155

Salt mist EN 50 155

Identification	Part number	Drawing	Dimensions in mm
----------------	-------------	---------	------------------

Ha-VIS RFID RF-R400

EU version  
US version

20 91 107 1101  
20 91 107 1102

### Optional accessories

DIN rail mounting kit

20 93 102 0201

M8 cable assembly  
(2 m, for power supply - VCC)\*\*

21 34 810 0489 020

M8 cable assembly  
(2 m, for RS 232, relay)\*\*

21 34 B20 0821 020

M8 cable assembly  
(2 m, for IO)\*\*

21 34 730 0821 020

M12 D-coded Ethernet cable  
(3 m)\*\*

09 45 700 5025

Han® 3 A RF-R400, M8 adapter\*\*\*  
(ideal for railway applications)

61 04 204 0036 00

Protection Set IP54 RF-R400

20 93 901 0111

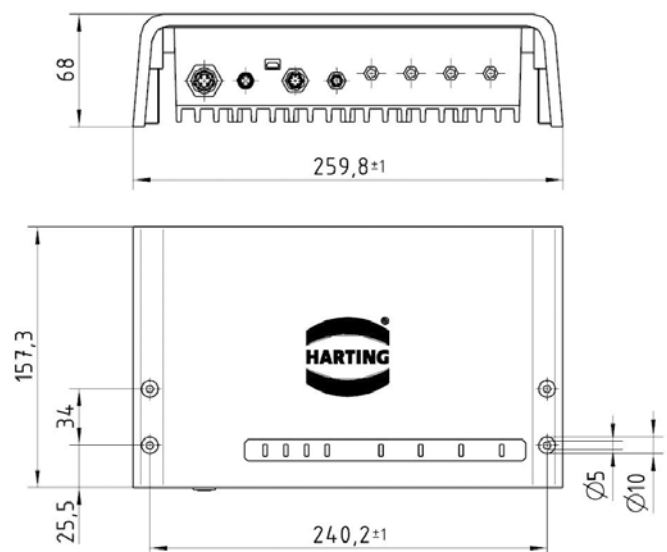

\*\* length just an example, another lengths on request

\*\*\* suitable cable assemblies that can be connected to this adapter can be manufactures on request



Ha-VIS RFID RF-R400 Reader

## Technical characteristics

### Connectors / Pin assignment

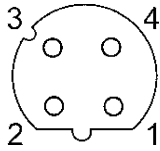
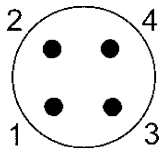
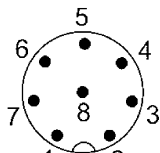
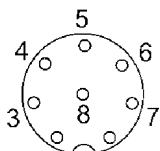
LAN (D-coded)		
1	TX+	
2	TX-	
3	RX+	
4	RX-	
VCC		
1	24 V-in	
2	24 V-in	
3	GND-in	
4	GND-in	
RS232 / RELAY		
1	RS232-RxD	
2	RS232-TxD	
3	GND	
4	+24 VDC	
5	RELAIS1-NO	
6	RELAIS1-COM	
7	RELAIS2-NO	
8	RELAIS2-COM	
IO		
1	OPTO-OUT1-E	
2	OPTO-OUT1-C	
3	OPTO-OUT2-E	
4	OPTO-OUT2-C	
5	OPTO-IN1-	
6	OPTO-IN1+	
7	OPTO-IN2-	
8	OPTO-IN2+	