

### PRODUCT FEATURES

- Hot-pluggable SFP+ transceiver module
- Supports 9.95 to 11.3Gb/s data links
- 10GBASE-LR/LW 10G Ethernet
- 10G Fibre Channel
- SONET OC-192 / SDH
- 1310nm DFB transmitter
- PIN photo-detector
- RoHS compliant and Lead Free
- Up to 10km reach on Singlemode (SMF)
- Metal enclosure for lower EMI
- Duplex LC Connector
- Single +3.3V power supply
- Power consumption <1.5W
- Commercial operating temperature range: -0°C to 70°C
- 2-wire interface for management specifications compliant
- SFF 8472 digital diagnostic monitoring interface



### REGULATORY COMPLIANCE

- ESD to the Electrical PINs: compatible with MIL-STD-883E Method 3015.7
- ESD to the LC Receptacle: compatible with IEC 61000-4-2 GR-1089-CORE
- Immunity compatible with IEC 61000-4-2
- EMI compatible with FCC Part 15 Class B EN55022 Class B (CISPR 22B) VCCI Class B
- Laser Eye Safety compatible with FDA 21CFR 1040.10 and 1040.11 EN60950
- RoHS compliant with 2002/95/EC 4.1&4.2 2005/747/EC

**PIN DESCRIPTIONS**

Pin	Symbol	Name/Description	Ref.
1	VeeT	Transmitter Ground (Common with Receiver Ground)	1
2	TX Fault	Transmitter Fault. LVTTTL -I/O	2
3	TX Disable	Transmitter Disable. Laser output disabled on high or open. LVTTTL-I	3
4	SDA	2-Wire Serial Interface Data Line (Same as MOD-DEF2 in INF-8074i). LVTTTL-I/O	
5	SCL	2-Wire Serial Interface Data Line (Same as MOD-DEF2 in INF-8074i). LVTTTL-I	
6	Mod_ABS	Module Absent, Connect to VeeT or VeeR in Module	4
7	RH0	Rate Select 0, optionally controls SFP+ module receiver LVTTTL-I	5
8	LOS	Loss of Signal indication. Logic 0 indicates normal operation	2
9	RS1	Rate Select 0, optionally controls SFP+ module receiver LVTTTL-I	5
10	VeeR	Receiver Ground (Common with Transmitter Ground)	1
11	VeeR	Receiver Ground (Common with Transmitter Ground)	1
12	RD-	Receiver Inverted DATA out. AC Coupled	
13	RD+	Receiver Non-Inverted DATA out. AC Coupled	
14	VeeR	Receiver Ground (Common with Transmitter Ground)	1
15	VccR	Receiver Power Supply	
16	VccT	Transmitter Power Supply	
17	VeeT	Transceiver Ground (Common with Transmitter Ground)	1
18	TD+	Transceiver Non-Inverted DATA in. AC Coupled	
19	TD-	Transmitter Inverted DATA in. AC Coupled	
20	VeeT	Transmitter Ground (Common with Receiver Ground)	1

**Notes:**

1. The module signal ground contacts, VeeR and VeeT, should be isolated from the module case.
2. This contact is an open collector/drain output and should be pulled up to the Vcc\_Host with resistor in the range 4.7KΩ to 10KΩ. Pull ups can be connected to one or several power supplies, however the host board design shall ensure that no module contact has voltage exceeding module VccT/R +0.5V.
3. Tx\_Disable is an input contact with a 4.7KΩ to 10KΩ pull-up resistor to VccT inside module.
4. Mod\_ABS is connected to VeeT or VeeR in the SFP+ module. The host may pull the contact up to Vcc\_Host with a resistor in the range from 4.7KΩ to 10KΩ. Mod\_ABS is asserted “High” when the SFP+ module is physically absent from a host slot.
5. RS0 and RS1 are module inputs and are pulled low to VeeT with > 30 kΩ resistors in the module. RS0 optionally selects the optical receive signaling rate coverage. RS1 optionally selects the optical transmit signaling rate coverage.

## PIN-OUT OF CONNECTOR BLOCK ON HOST

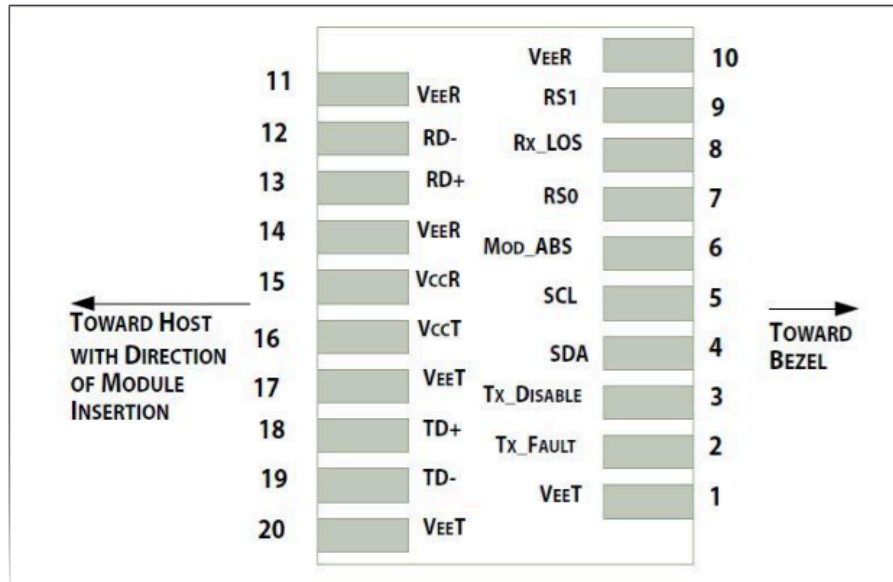

## RECOMMENDED CIRCUIT SCHEMATIC

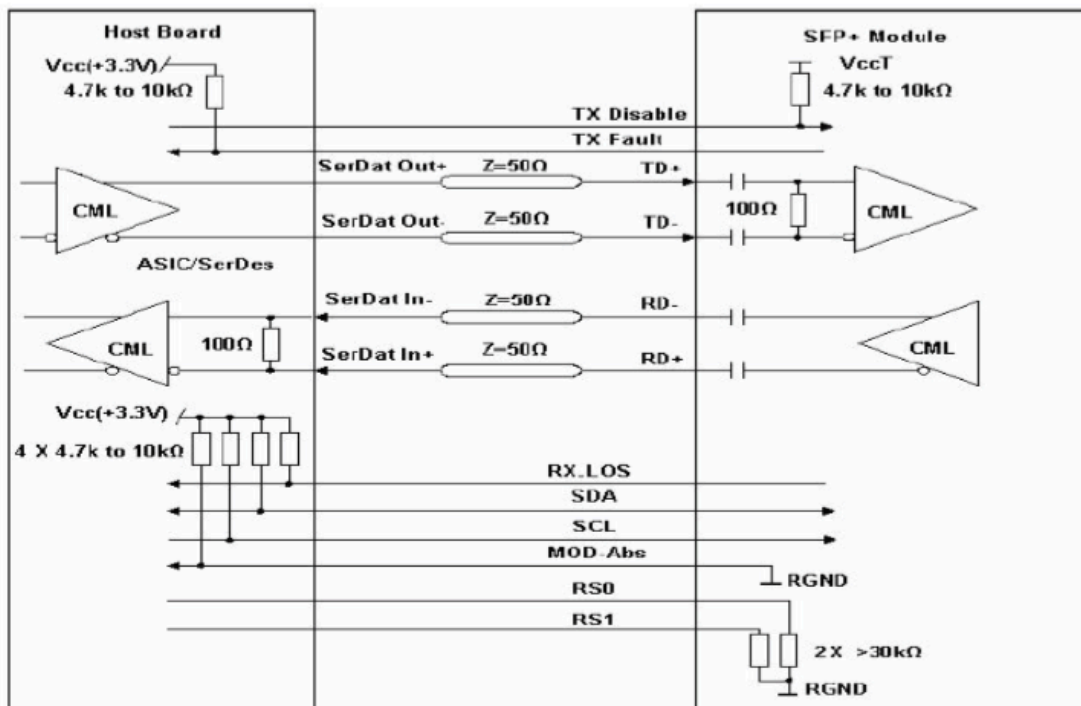

**ABSOLUTE MAXIMUM RATING**

Parameter	Symbol	Min	Typ	Max	Unit	Ref.
Maximum Supply Voltage	Vcc	-0.5	-	+4.0	V	
Storage Temperature	TS	-40	-	+85	°C	
Operating Humidity	RH	5	-	85	%	

**RECOMMENDED OPERATING CONDITIONS**

Parameter	Symbol	Min	Typ	Max	Unit	Ref.
Power Supply Voltage	Vcc	3.13	3.30	3.47	V	
Power Supply Current	Icc	-	-	430	mA	
Case Operating Temperature	Tc	0	-	+70	°C	
Data Rate	-	9.95	10.5	11.3	Gbps	

**ELECTRICAL CHARACTERISTICS (TOP=25°C, VCC=3.3Volts)**

Parameter	Symbol	Min	Typ	Max	Unit	Ref.
<b>Transmitter</b>						
Input differential impedance	Zin	90	100	110	Ω	
Differential data input swing	Vin, pp	180	-	700	mV	
TX Disable-High	-	2.0	-	Vcc+0.3	V	
TX Disable-Low	-	Vee-0.3	-	0.8	V	
TX Fault-High	-	2.0	-	Vcc	V	
TX Fault-Low	-	Vee	-	Vee+0.8	V	
<b>Receiver</b>						
Single ended data output swing	Vout, pp	300	600	850	mV	
Output Differential Impedance	Zin	90	100	110	Ω	
LOS-High	-	2.0	-	VccHOST	V	
LOS-Low	-	Vee	-	Vee+0.8	V	

### OPTICAL CHARACTERISTICS

Parameter	Symbol	Min	Typ	Max	Unit
<b>Transmitter</b>					
Output Opt. Power	AOP	-8.2		0.5	dBm
Optical Modulation Amplitude	P(OMA)	-5.2			dBm
Extinction Ratio	ER	3.5			dB
Transmitter and Dispersion Penalty	TDP			3.2	dB
Average Launch Power of OFF TX	Poff			-30	dBm
Optical Wavelength	$\lambda$	1290	1310	1330	nm
Spectral Width				1	nm
Optical Return Loss Tolerance	ORLT	20			dB
Relative Intensity Noise	RIN			-128	dB/Hz
Transmitter Reflectance				-12	dB
<b>Receiver</b>					
RX Sensitivity	PIN			-14.5	dBm
Overload	Sat	0			dBm
Receiver Reflectance	Rrx			-12	dB
Optical Center Wavelength	$\lambda_C$	1260		1355	nm
LOS Assert	LOSA	-25			dBm
LOS De-Assert	LOSD			-15	dBm
LOS Hysteresis	LOSH	0.5			dB

### MECHANICAL SPECIFICATIONS

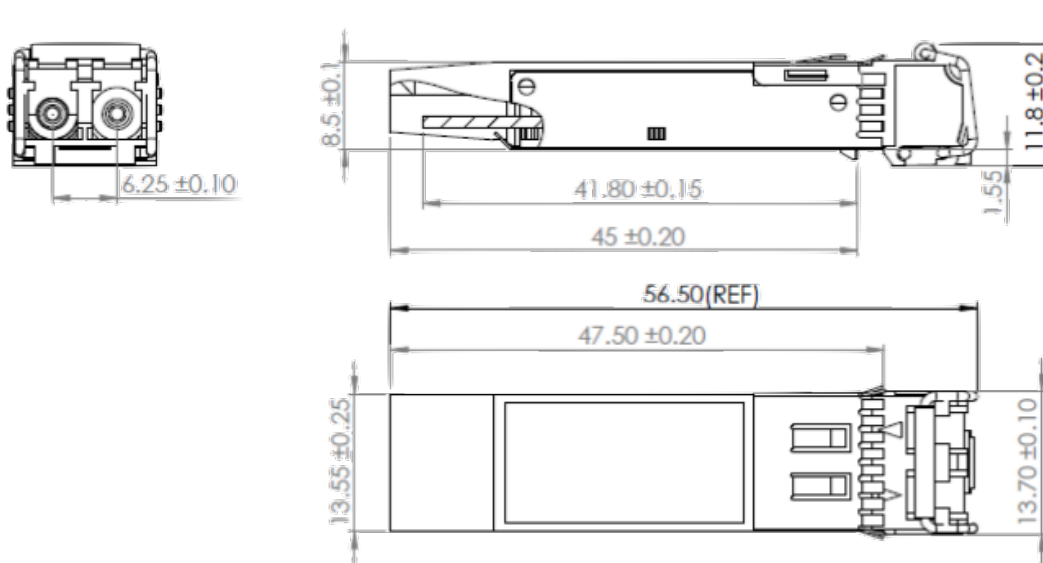

### EEPROM INFORMATION

EEPROM memory map specific data field description is as below:

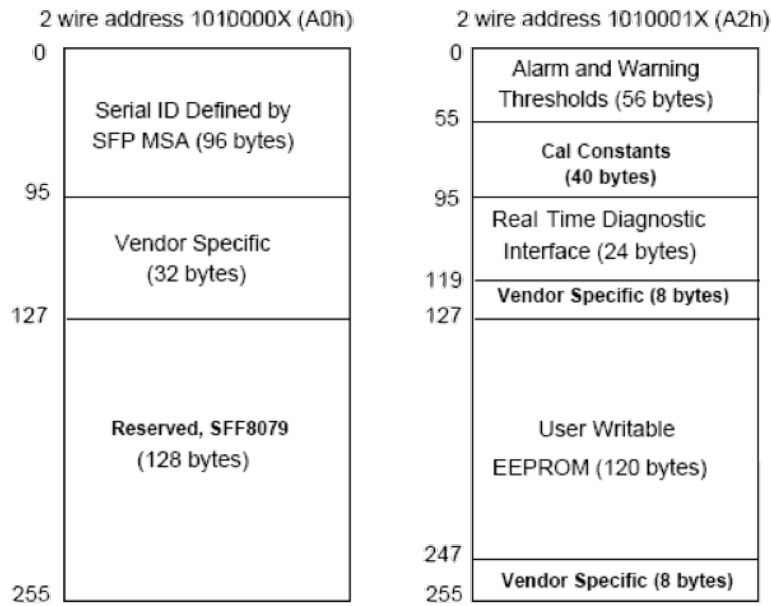

### DIGITAL DIAGNOSTIC MONITORING INTERFACE

The digital diagnostic monitoring interface also defines another 256-byte memory map in EEPROM, which makes use of the 8 bit address 1010001X (A2h). The monitoring specification of this product is described in this table.

Parameter	Range	Accuracy	Calibration
Temperature	0°C to 70°C	±3°C	Internal
Voltage	2.97 to 3.63V	±3%	Internal
Bias Current	0 to 100mA	±10%	Internal
TX Power	-5 to 1dBm	±2dB	Internal
RX Power	-11.1 to -1dBm	±3dB	Internal