

- 1
- 2
- 3
- 4
- 5
- 6
- 7
- 8
- 9
- 10
- 11
- 12
- 13
- 14
- 15
- 16
- 17
- 18

STANDARD EXECUTIONS

- **LM.:**
 - zinc-plated steel base and ball joint with threaded blind hole.
 - zinc-plated steel base and ball joint with threaded stem and nut.
 - **LM-SST:**
 - AISI 303 stainless steel base and ball joint with threaded blind hole.
 - AISI 303 stainless steel base and ball joint with threaded stem.
- AISI 304 stainless steel nut.

FEATURES

The resistance of the levelling element to a static load is obviously limited by the load capacity of the stem.

The static load values in the table below refer to the resistance to a load applied on the axis of the levelling foot.

Under common working conditions, side or angular loading increases the stress on the stem and reduces its load capacity.

To increase the applicable load you can use the ball joint with threaded hole by inserting a steel threaded bar of higher resistance class. We recommend to insert a pressure pad between the end of the bar and the bottom of the threaded hole to reduce loading on the threading.

SPECIAL EXECUTIONS ON REQUEST

Executions with antistatic no-slip coating.

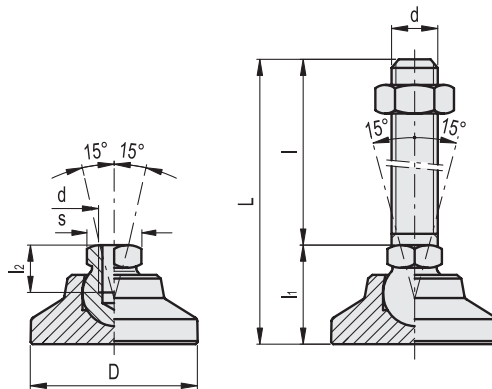

Conversion Table	
1 mm = 0.039 inch	
D	
mm	inch
25	0.98
32	1.26
40	1.57
50	1.97
60	2.36

Levelling feet and supports

LM (d)

METRIC

LM-SST (d)

INOX STAINLESS STEEL

METRIC

Code	Description	D	d	l1	l2	s	Max. limit static load [N]	⚖️	Code	Description	Max. limit static load [N]	⚖️
401020	LM.25 M6	25	M6	19	9	12	7500	26	402020	LM.25-SST M6	4000	26
401021	LM.25 M8	25	M8	19	9	12	14000	30	402021	LM.25-SST M8	7000	30
401030	LM.32 M8	32	M8	23	9	12	14000	62	402030	LM.32-SST M8	7000	62
401031	LM.32 M10	32	M10	23	10.5	15	23000	64	402031	LM.32-SST M10	11000	64
401040	LM.40 M10	40	M10	26	10.5	15	23000	106	402040	LM.40-SST M10	11000	106
401041	LM.40 M12	40	M12	26	11.5	17	33000	108	402041	LM.40-SST M12	16000	108
401050	LM.50 M10	50	M10	28	10.5	15	23000	173	402050	LM.50-SST M10	11000	173
401051	LM.50 M12	50	M12	28	11.5	17	33000	175	402051	LM.50-SST M12	16000	175
401060	LM.60 M12	60	M12	36	11.5	17	33000	315	402060	LM.60-SST M12	16000	315
401061	LM.60 M16	60	M16	36	16	24	62000	320	402061	LM.60-SST M16	30000	320

LM. (d - l)

METRIC

LM-SST (d - l)

INOX STAINLESS STEEL

METRIC

Code	Description	D	d	L	l	li	s	Max. limit static load [N]	⚖️	Code	Description	Max. limit static load [N]	⚖️
401520	LM.25 M6x40	25	M6	59	40	19	12	7500	39	402511	LM.25-SST M6x40	4000	39
401521	LM.25 M6x50	25	M6	69	50	19	12	7500	41	402512	LM.25-SST M6x50	4000	41
401522	LM.25 M6x63	25	M6	82	63	19	12	7500	45	402513	LM.25-SST M6x63	4000	45
401523	LM.25 M8x40	25	M8	59	40	19	12	14000	50	402523	LM.25-SST M8x40	7000	57
401524	LM.25 M8x50	25	M8	69	50	19	12	14000	55	402524	LM.25-SST M8x50	7000	55
401526	LM.25 M8x63	25	M8	82	63	19	12	14000	65	402526	LM.25-SST M8x63	7000	67
401527	LM.25 M10x50	25	M10	69	50	19	12	23000	54	402516	LM.25-SST M10x50	11000	54
401528	LM.25 M10x63	25	M10	82	63	19	12	23000	64	402517	LM.25-SST M10x63	11000	64
401529	LM.25 M10x80	25	M10	99	80	19	12	23000	76	402518	LM.25-SST M10x80	11000	76
401530	LM.32 M8x40	32	M8	63	40	23	12	14000	52	402530	LM.32-SST M8x40	7000	52
401531	LM.32 M8x50	32	M8	73	50	23	12	14000	57	402531	LM.32-SST M8x50	7000	57
401532	LM.32 M8x63	32	M8	86	63	23	12	14000	67	402532	LM.32-SST M8x63	7000	67
401533	LM.32 M10x50	32	M10	73	50	23	15	23000	110	402533	LM.32-SST M10x50	11000	113
401534	LM.32 M10x63	32	M10	86	63	23	15	23000	126	402534	LM.32-SST M10x63	11000	126
401536	LM.32 M10x80	32	M10	103	80	23	15	23000	145	402536	LM.32-SST M10x80	11000	129
401535	LM.32 M12x63	32	M12	86	63	23	15	33000	166	402527	LM.32-SST M12x63	16000	166
401537	LM.32 M12x80	32	M12	103	80	23	15	33000	183	402528	LM.32-SST M12x80	16000	183
401538	LM.32 M12x100	32	M12	123	100	23	15	33000	201	402529	LM.32-SST M12x100	16000	201
401539	LM.40 M8x50	40	M8	76	50	26	15	14000	142	402537	LM.40-SST M8x50	7000	142
401545	LM.40 M8x63	40	M8	89	63	26	15	14000	150	402538	LM.40-SST M8x63	7000	150
401547	LM.40 M8x80	40	M8	106	80	26	15	14000	158	402539	LM.40-SST M8x80	7000	158
401540	LM.40 M10x50	40	M10	76	50	26	15	23000	157	402540	LM.40-SST M10x50	11000	157
401541	LM.40 M10x63	40	M10	89	63	26	15	23000	165	402541	LM.40-SST M10x63	11000	165
401542	LM.40 M10x80	40	M10	106	80	26	15	23000	172	402542	LM.40-SST M10x80	11000	172
401543	LM.40 M12x63	40	M12	89	63	26	17	33000	180	402543	LM.40-SST M12x63	16000	185
401544	LM.40 M12x80	40	M12	106	80	26	17	33000	185	402544	LM.40-SST M12x80	16000	185
401546	LM.40 M12x100	40	M12	126	100	26	17	33000	205	402546	LM.40-SST M12x100	16000	211
401548	LM.50 M8x50	50	M8	78	50	28	15	14000	172	402547	LM.50-SST M8x50	7000	172
401549	LM.50 M8x63	50	M8	91	63	28	15	14000	180	402548	LM.50-SST M8x63	7000	180
401555	LM.50 M8x80	50	M8	108	80	28	15	14000	187	402549	LM.50-SST M8x80	7000	187
401550	LM.50 M10x50	50	M10	78	50	28	15	23000	207	402550	LM.50-SST M10x50	11000	207
401551	LM.50 M10x63	50	M10	91	63	28	15	23000	215	402551	LM.50-SST M10x63	11000	215
401552	LM.50 M10x80	50	M10	108	80	28	15	23000	222	402552	LM.50-SST M10x80	11000	222
401553	LM.50 M12x63	50	M12	91	63	28	17	33000	250	402553	LM.50-SST M12x63	16000	258
401554	LM.50 M12x80	50	M12	108	80	28	17	33000	260	402554	LM.50-SST M12x80	16000	260
401556	LM.50 M12x100	50	M12	128	100	28	17	33000	275	402556	LM.50-SST M12x100	16000	283
401557	LM.50 M16x63	50	M16	91	63	28	17	40000	286	402557	LM.50-SST M16x63	30000	286
401558	LM.50 M16x80	50	M16	108	80	28	17	40000	298	402558	LM.50-SST M16x80	30000	298
401559	LM.50 M16x100	50	M16	128	100	28	17	40000	311	402559	LM.50-SST M16x100	30000	311
401587	LM.60 M10x50	60	M10	86	50	36	17	23000	367	402567	LM.60-SST M10x50	11000	367
401588	LM.60 M10x63	60	M10	99	63	36	17	23000	386	402568	LM.60-SST M10x63	11000	386
401589	LM.60 M10x80	60	M10	116	80	36	17	23000	405	402569	LM.60-SST M10x80	11000	405
401560	LM.60 M12x63	60	M12	99	63	36	17	33000	440	402560	LM.60-SST M12x63	16000	440
401561	LM.60 M12x80	60	M12	116	80	36	17	33000	465	402561	LM.60-SST M12x80	16000	465
401562	LM.60 M12x100	60	M12	136	100	36	17	33000	500	402562	LM.60-SST M12x100	16000	500
401563	LM.60 M16x80	60	M16	116	80	36	24	62000	495	402563	LM.60-SST M16x80	30000	510
401565	LM.60 M16x100	60	M16	136	100	36	24	62000	520	402565	LM.60-SST M16x100	30000	520
401566	LM.60 M16x125	60	M16	161	125	36	24	62000	545	402566	LM.60-SST M16x125	30000	561
401571	LM.60 M20x98	60	M20	134	98	36	24	95000	550	402571	LM.60-SST M20x98	45000	550
401573	LM.60 M20x138	60	M20	174	138	36	24	95000	580	402573	LM.60-SST M20x138	45000	580
401576	LM.60 M20x158	60	M20	194	158	36	24	95000	610	402576	LM.60-SST M20x158	45000	610
401581	LM.60 M24x98	60	M24	134	98	36	24	95000	610	402581	LM.60-SST M24x98	45000	610
401583	LM.60 M24x138	60	M24	174	138	36	24	95000	630	402583	LM.60-SST M24x138	45000	630
401586	LM.60 M24x158	60	M24	194	158	36	24	95000	650	402586	LM.60-SST M24x158	45000	650

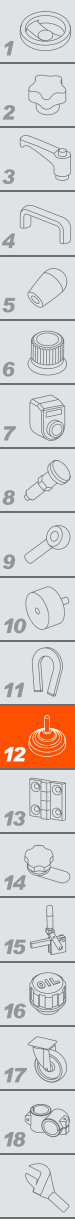

Levelling elements and supports