

LTC6563

Four-Channel Differential-Output Transimpedance Amplifier with Output Multiplexing

DESCRIPTION

Demonstration circuit EVAL-LTC6563-TQFN features the [LTC6563](#) four-channel transimpedance amplifier (TIA) with output multiplexing. This demo kit, EVAL-LTC6563TQFN-EZKIT shipped along with the SDP-K1 controller board, has 4 installed single APD's which allows optical testing of the TIA functionality. Electrical testing using an external lab pulse generator, as the input current pulse, is also possible with small board modifications.

With its 20kΩ transimpedance gain and 90μA linear input current range, the LTC6563 is ideal for LIDAR receivers using Avalanche Photodiodes (APD). The LTC6563 operates from 3.3V single supply and consumes only 194mW (depending on output mode) for 4 channels. Utilizing the LTC6563's output MUX, multiple LTC6563 devices can be combined to a single output. The LTC6563's fast overload recovery makes it well-suited for LIDAR receivers. The LTC6563's differential output can swing 2V_{P-P} into a 100Ω load, ideal for driving a high-speed ADC directly.

The LTC6563 is packaged in a compact 3mm × 5mm 24-pin leadless QFN package with an exposed pad for thermal management and low inductance.

The EVAL-LTC6563-TQFN utilizes four installed 400-1100nm APD sensors feeding the LTC6563 for current-to-voltage conversion and amplification. The APDs are DC-coupled to the TIAs to facilitate fast output multiplexing and channel switching. Alternatively, with small board modifications, it is possible to electrically excite the LTC6563 using a lab generator tied to SMA connectors provided on the board and voltage-to-current resistors on the board. The EVAL-LTC6563-TQFN is intended to demonstrate time-domain measurements into 50Ω systems.

NOTE: This document applies to EVAL/Demo boards which have Rev. A3 label attached to the bottom side.

[Design files for this circuit board are available.](#)

All registered trademarks and trademarks are the property of their respective owners.

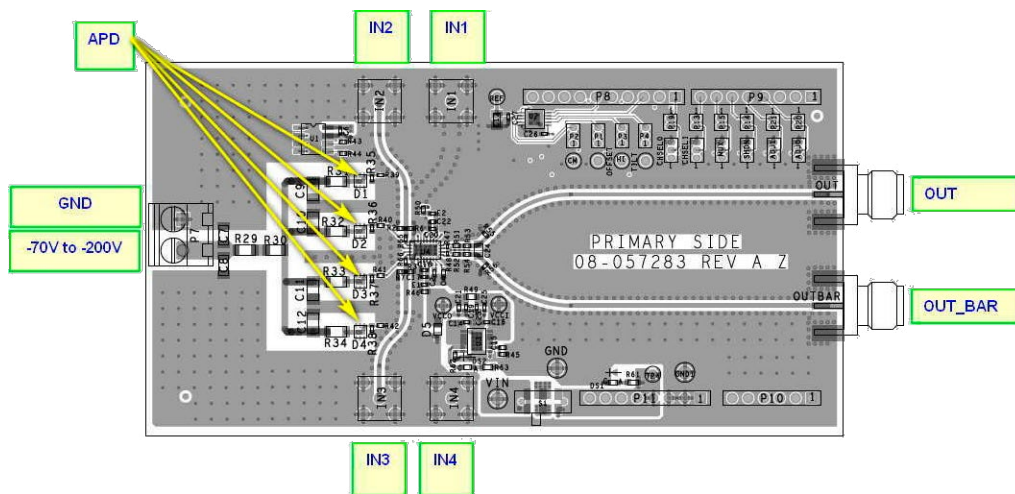

Figure 1. Connection Diagram (IN1 to IN4 Optional for Electrical Testing Only)

DEMO MANUAL

EVAL-LTC6563-TQFN

DESCRIPTION

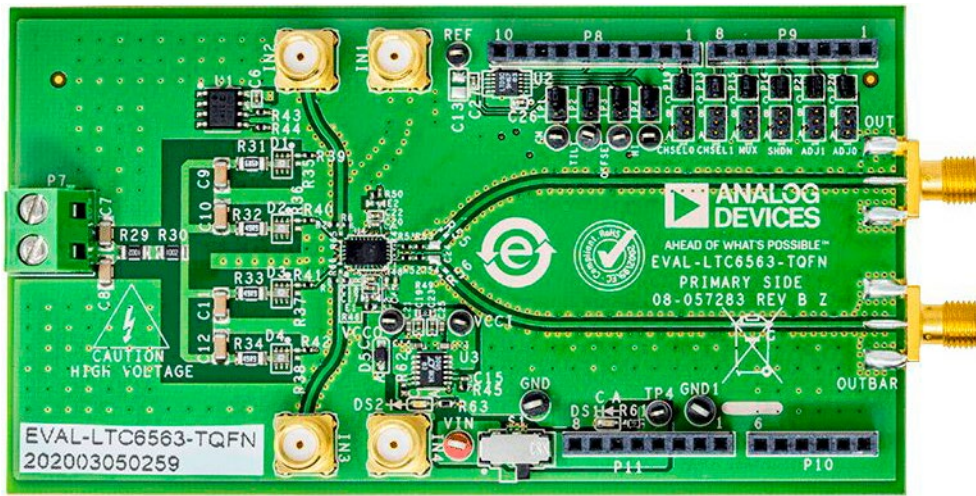

Figure 2. LTC6563 EVAL Board Top Side

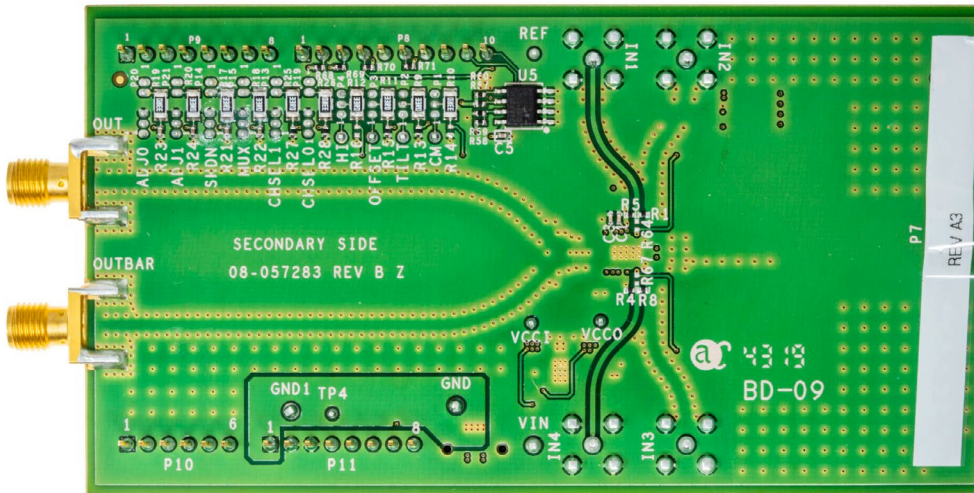

Figure 3. LTC6563 EVAL Board Back Side

QUICK START PROCEDURE

Use with SDP-K1 Controller Board

The DEMO kit is supplied with the SDP-K1 controller board plugged-in directly below the EVAL board. The SDP-K1, when connected to a PC, using the supplied USB cable, with an installed serial port terminal program like Coolterm, allows the user to power the EVAL board and also to control and save the LTC6563 operating state and analog control voltages. The only other power supply needed is the HV (–120V) DC power for APD biasing.

For optical pulse testing, an external laser source is needed to excite the on-board APDs. The TIA differential output voltage can then be monitored by driving an ADC (tied to output SMAs) analog input(s), or by using a dual channel oscilloscope. With the laser pulses illuminating the selected APD (one of four), the optical response will be displayed on the oscilloscope and Coolterm can be used to manipulate and save (nonvolatile) the LTC6563 operating conditions and control voltages.

The pre-programmed SDP-K1 controller board performs the following functions:

1. Power the EVAL-LTC6563-TQFN EVAL board. NOTE: The APD high-voltage bias must be provided separately through P7.
2. Control the LTC6563 analog control functions (Offset, HI, CM, and Tilt) using the on-board DAC.

3. Control the I/O States (CHSEL0, CHSEL1, OMUX, PWRMD (also called SHDN on the board silkscreen and schematic), ADJ1, ADJ0).
4. Write the values/states of these same functions into the on-board EEPROM to be retrieved automatically upon power-up.
5. Store the settings in the EEPROM.
6. Return the device to the default factory state/DAC values.

Quick Setup with SDP-K1 Controller Board

To allow the operation of EVAL-LTC6563-TQFN using SDP-K1:

1. Download Coolterm or other similar USB-serial terminal application program off the web (if not already installed) using the link shown under the Equipment List.
2. Launch Coolterm.
3. Plug the SDP-K1 onto the bottom of EVAL-LTC6563-TQFN as shown in Figure 4 (if not already).
4. Go to the Default Factory hardware Settings listed in Figure 7 (if not already):
 - a. Move EVAL-LTC6563-TQFN S1 switch to the right (towards connector P11, see Figure 4) to power the EVAL board using the SDP-K1 if not already.

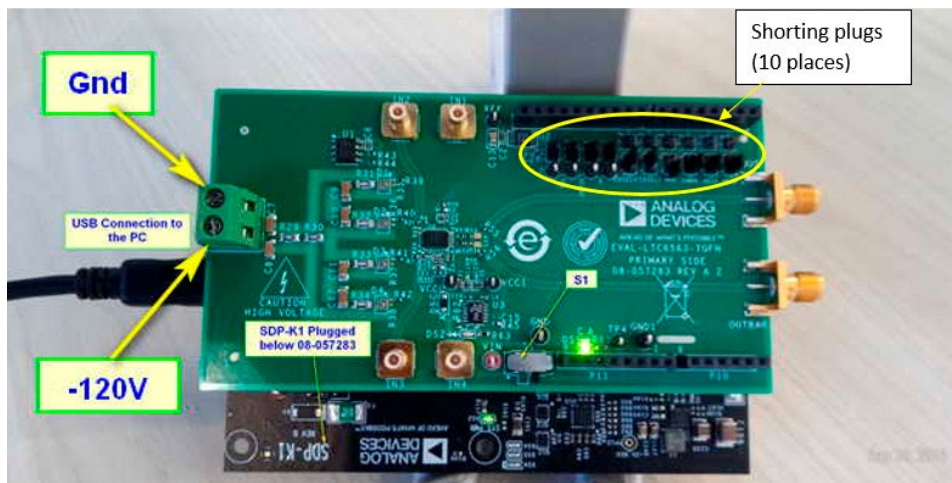

Figure 4. SDP-K1 Connection (WARNING: HIGH VOLTAGE PRESENT!)

QUICK START PROCEDURE

Now the board(s) are connected and the commands in the Coolterm Command Summary can be executed.

7. Apply the external -120V DC power supply to P7 (pin 2) with pin 1 tied to power supply ground. This is the appropriate bias voltage for the APDs installed on the board. The connector and passives are rated up to 300V . See Figure 4 for the proper P7 high voltage polarity connection.
8. Using a coax cable, tie OUT SMA to the oscilloscope Ch1 set to 50Ω termination, 0.2V/div .
9. Using a coax cable, tie OUTBAR SMA to the oscilloscope Ch2 set to 50Ω termination, 0.2V/div .
10. Using an external 400nm to 1100nm wavelength pulsed laser, similar to the one identified in the Equipment List as the ST micro light source, illuminate the APDs, which are identified in Figure 1. With the default board setting which selects IN1 or Ch1 (CHSELO = CHSEL1 = 0), position the laser to illuminate the Ch1 APD (D1).
11. With a 5ns duration laser pulse width from this light source, the Figure 8 typical scope waveforms can be

expected at OUT and OUTBAR SMAs (Ch1: OUT, Ch2: OUTBAR):

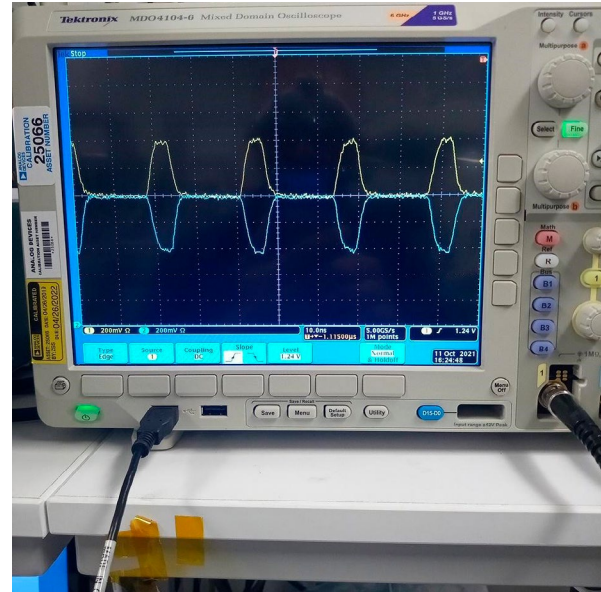

Figure 8. OUT and OUTBAR Typical Waveforms

The LTC6563 EVAL board is now setup and under the SDP-K1 control for adjustment and control (if needed).

LTC6563 ADJUSTMENTS AND CONTROLS

Setting DAC Voltages

With the Set DAC command in Coolterm (invoked by entering 2 and Enter), each of the 4 DAC outputs (4 places) can be varied from 0V to 2.5V (or using decimal equivalent from 0 to 65,536). Once the voltages are set, Store Settings to EEPROM (command 3, and Enter) will save the modified DAC values (and I/O pin states described further below) to the EEPROM. These voltages, along with I/O pin states, will be automatically recalled and written to the DAC and I/O states upon the next power cycle for easy return to last saved operating conditions. CAUTION: To avoid getting the wrong DAC voltage, do not exceed 2.5V (0xFFFF) when entering a DAC voltage.

The Current State in Coolterm shows the current settings of all the registers for easy reference.

Here is a summary of these default conditions set at the factory:

- IN1 selected (CHSELO = CHSEL1 = 0)
- OMUX = Logic HI (output MUX active)
- PWRMD = Logic HI (Inactive channels/inputs powered up)
- Maximum output current (ADJ0 = ADJ1 = 1)
- Offset correction off ((offset) = 0V)
- Output Clamp not used ((HI) = 2.5V)
- CM set to 1V ((CM) = 1V)
- Tilt set to 0V ((Tilt) = 0V)
- RL_EXT (external differential load) = 100Ω (oscilloscope inputs set to 50Ω)

LTC6563 ADJUSTMENTS AND CONTROLS

- TERM and TERMBAR shorted to OUT and OUTBAR respectively (through R47, R48 0Ω resistors on the board)

Setting I/O Pin States

With the Set IO command, activated by entering 1 and Enter, the following device pin states can be set to either 0 or 1.

Select I/O Pin:

- 1 - CHSEL0 Pin
- 2 - CHSEL1 Pin
- 3 - OMUX Pin
- 4 - PWRMD Pin
- 5 - ADJ1 Pin
- 6 - ADJ0 Pin

Once in Set IO command mode in Coolterm, enter a number between 1-6 (followed by Enter) corresponding to the pin state to be changed.

Next, enter either 0 or 1, and SDP-K1 will set the selected pin to the state specified.

NOTE: The board silkscreen and schematic calls PWRMD pin as SHDN.

Saving Default State

To save the DAC voltages and I/O pin states onto the EEPROM, enter command 3 and Return. To return the board to the default factory settings, enter command 4 followed by Enter.

OPERATING THE BOARD IN STAND-ALONE MODE (WITHOUT SDP-K1)

If necessary or desired, the LTC6563 EVAL board can be operated without the SDP-K1. For this mode of operation, the board should be powered externally (5V DC power supply) and switch S1 positioned per Table 1. The I/O pins and analog control voltage shorting jumpers on the board (10 places total) need to be moved per Table 1. These shorting jumpers allow setting the I/O pins (6 places) to either 0 or 1. With the analog control voltage jumpers (4

places) moved, the required DC voltage (from 0V to 2.5V) should be supplied to all 4 turrets/posts on the board externally using any of the following:

- DACs.
- DC control voltages such as lab power supplies.
- Potentiometers placed between ground and VCC.

Table 1. Operation Modes Summary

CONDITION/SETUP	STAND-ALONE OPERATION (See Figure 2)	OPERATION WITH SDP-K1 (See Figure 4)	NOTES
Switch S1	Slide to the left	Slide to the right	S1 used to switch between external 5V power sources or 5V from SDP-K1.
External +5V power to VIN and GND turrets	Required. >0.5A capable	Not required. Remove any external power supply connections	SDP-K1 (if present) provides the 5V power for the 3.3V LDO on-board and no external power supply is needed.
Jumpers P1-P4 (4 places, near P8)	Move to lowest positions on the board (towards P11), 3-pin connector. Need external voltage to drive turrets	Move to highest positions on the board (towards P8), 3-pin connector. SDP-K1 will set these voltages	Device analog control inputs (4 places) controlled by SDP-K1 (if present). Otherwise, control voltages (turrets next to these 3-pin jumpers) must be tied to appropriate external voltage sources/DACs for control with P1 to P4 shorting jumpers moved towards these turrets.
Jumpers P13 to P15 and P19 to P21 (6 places, near P9)	Move to lowest positions on the board (towards P10), 3-pin connector to select 1 or 0	Move to highest positions on the board (towards P9), 2-pin connector. SDP-K1 will set these voltages	Device I/O control inputs (6 places) controlled by SDP-K1 (if present). Otherwise, control voltages can be set by placing the shorting jumper in the A silkscreen location for 1, or B silkscreen position for 0.

OPERATING THE BOARD IN STAND-ALONE MODE (WITHOUT SDP-K1)

1. Power:
 - a. Stand-alone Operation: Move switch S1 slider to the left (towards VIN test point), connect a low-noise 5V power supply between VIN and GND test points to power the board.
2. Apply the external -120V DC power supply to P7 (pin 2) with pin 1 tied to power supply ground. This is the appropriate bias voltage for the APDs installed on the board. The connector and passives are rated up to 300V. See Figure 4 for the proper P7 high voltage polarity connection.
3. Connect OUT and OUTBAR SMAs to an oscilloscope with at least two channels that is 50Ω terminated on each input. The output(s) are DC coupled. With the device internal 50Ω terminations (TERM and TERMBAR pins tied to OUT and OUTBAR respectively), each output will then see a net 25Ω load or 50Ω diff load.
4. Move the board jumpers to the positions stated in Table 1 for stand-alone operation.
5. Analog Controls: The following are analog controls which can be varied by applying the voltage desired to the turrets (test points) on the board (see Table 1): CM, Tilt, Offset, HI.

The allowable voltage range on these four turrets are 0V–2.5V. Alternatively, SDP-K1 (if present) controller board can vary these via a DAC (U2) on-board.

Move the miniature 3-pin shorting jumpers next to each of these four turrets to the bottom (away from P8) for external voltage control, or alternatively to the top (towards P8) for SDP-K1 (if present) control.
6. Digital Controls: The following device pins can take on either 0 or 1 state (3.3V):

CHSEL0, CHSEL1, MUX, SHDN (or PWRMD), ADJ1, ADJ0.

Move the miniature 3-pin shorting jumpers next to each turret to the bottom (away from P8, silkscreen A) for state 1, or to the top (towards P8, silkscreen B) for state 0.

Alternatively, remove the shorting jumpers from these 6 jumpers and move to the top 2 pin headers next to each control, in order to enable SDP-K1 (if present) control instead.

7. Apply a 400nm to 1100nm wavelength pulsed laser, similar to the one identified in the Equipment List as the ST micro light source, to the APDs, which are identified in Figure 1. With a 5ns duration laser pulse width from this light source, the Figure 9 typical scope waveforms can be expected at OUT and OUTBAR SMAs (Ch1: OUT, Ch2: OUTBAR):

The LTC6563 EVAL board is now setup in stand-alone mode.

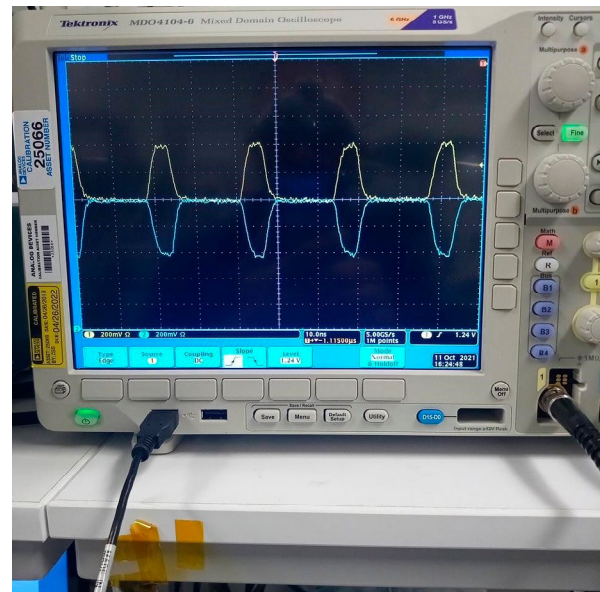

Figure 9. OUT and OUTBAR Typical Waveforms

GENERAL DESCRIPTION

Power supply

3.3V power is generated on-board using LT3045 (U3) low noise LDO at either VCCI or VCCO test point. Input power is either applied externally at VIN test point and ground, or, alternatively, the 5V from the SDP-K1 board (if present) is used as the raw input power source. Move switch S1 to the left (away from P11 to use an external power supply and to the right (towards P11) to use the SDP-K1 (if present) 5V power.

U3 powers both LTC6563 supply rails (VCCI and VCCO) which are tied together at one point on the board through a 0Ω resistor (R49). VCCI and VCCO both should read close to 3.3V when powered properly.

APD Negative Bias

To be applied between P7-1 (GND), and P7-2 (APD bias). Range is -70V to -200V depending on the temperature. -120V is used for this board testing at the factory. Use caution when handling the board because of this high voltage.

Board ID EEPROM

Mounted on the board bottom (U5). Used to identify the board when SDP-K1 (if present) is plugged onto the board. In addition, the EEPROM will restore the device to the last saved state and DAC settings at power up.

CM, Tilt, Offset, HI Controls

These LTC6563 control voltages can be externally applied to the board test points designated as such on the board silkscreen. Alternatively, there is a 4-channel 10-bit DAC (LTC2634, U2) on the EVAL board which can be used to control these 4 pins with the SDP-K1 board (if present). To use the DAC for control, move the corresponding shorting jumper (1P1 to 1P4, 3 pins select, 4 jumpers) towards the board top edge (toward P8), as highlighted in Figure 10. For information about these control voltages, consult the LTC6563 data sheet.

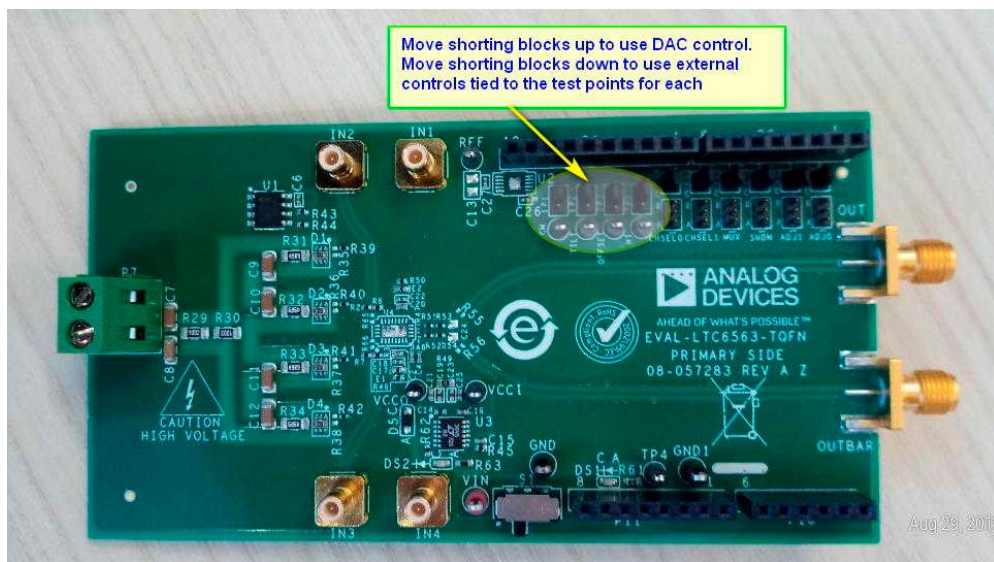

Figure 10. Shorting Blocks Position to Switch between DAC Control vs External Voltage Control

INPUT CIRCUIT DESCRIPTION

Input to the LTC6563 can be provided either optically (APD, D1 to D4 with appropriate negative bias applied to P7 pin 2 and pin 1 ground) the way the EVAL board is configured at the factory, or electrically using a lab generator tied to SMA's (IN1 to IN4) once the board is modified for electrical testing. The default board setting is for using APD's with R39 to R42 set to 0Ω; the resistors feeding the IN1 to IN4 SMA inputs (R64 to R67) are set to DNI (Do not install) which can be added to the board

(e.g. 2kΩ) for voltage-to-current conversion. With electrical testing, the APD's can be disconnected by removing R39-R42 (4 places).

For electrical testing purposes, follow these steps:

1. Install R64- R67 (2kΩ).
2. Remove R39-R42 (0Ω) optical coupling resistors.
3. Apply the electrical inputs to IN1 – IN4 SMAs.

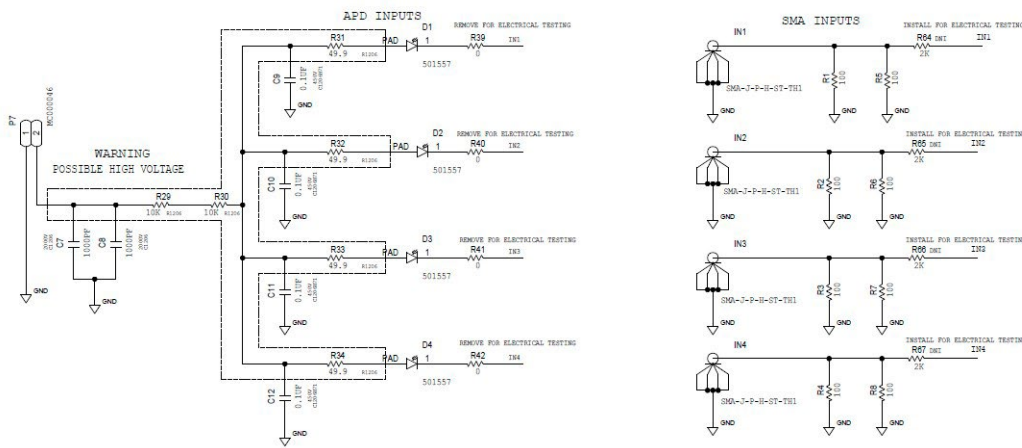

Figure 11. Input Stage Configuration Schematic

OUTPUT CIRCUIT DESCRIPTION

The output SMAs (OUT and OUTBAR) are configured to drive the differential analog inputs of appropriate ADCs directly. For testing purposes, these SMAs are to be tied to an oscilloscope terminated in 50Ω. The LTC6563 provides current output; an appropriate load resistor is required to create the voltage signal. TERM and TERMBAR pins have internal 50Ω resistors and also allow CM control of the outputs. These pins are tied to OUT and OUTBAR current outputs respectively on the board (through R47, and R48 0Ω resistors) to create the differential output voltage signals. With 50Ω scope inputs tied to OUT and OUTBAR, each LTC6563 output is loaded with 50Ω equivalent external load to ground or 100Ω external differentially.

Output common-mode voltage can be controlled by applying a voltage to the CM turret/test point or alternatively using SDP-K1 (if present) and proper board jumper settings. If the CM pin is not driven, it will float to a default voltage of 0.9V on a 3.3V supply. The V_{CM} pin should be bypassed with a high-quality ceramic bypass capacitor (C2 = 680pF on the current board).

Additional differential-mode filtering and ADC (if used at OUT and OUTBAR) charge kick-back storage is offered by using the R51, C24, R52 positions, if necessary, for the ADC being considered.

OUTPUT CIRCUIT DESCRIPTION

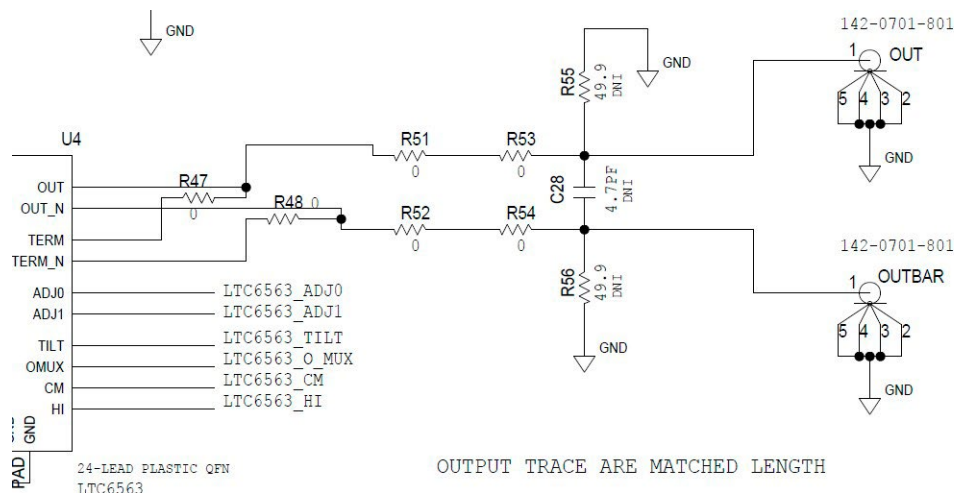

Figure 12. Output Configuration Schematic

Selecting Channels

The LTC6563’s multiplexing capability allows compact multichannel designs without external multiplexers, using the CHSEL1 (MSB) and CHSEL0 (LSB) device pins to select 1:4 channels. To select the active channel, the jumpers shown in Figure 13 can be used. With the jumper in the 1 position (side farthest from P9, silkscreen A), the channel select pin will be tied to V_{CC1} . In the 0 position (side closest to P8, silkscreen B), the channel select pin is grounded. Refer to Table 2 below for channel selection.

Alternatively, channel selection may be provided by SDP-K1 (if present) with the manual channel selection jumpers lifted out and instead moved to the 2 pin headers just above, as shown schematically in Figure 13 (from DC2026C which refers to the SDP-K1 board).

Table 2. Channel Selection

CHSEL1	CHSEL0	ACTIVE CHANNEL
0	0	1
0	1	2
1	0	3
1	1	4

To evaluate the LTC6563 channel-to-channel switching times, the center pin of the channel selection 3-pin jumpers can be tied to a high-speed pattern/pulse generator (with the plastic shorting block(s)/jumpers not used). These connections may need additional 50Ω termination resistors for best signal integrity.

OUTPUT CIRCUIT DESCRIPTION

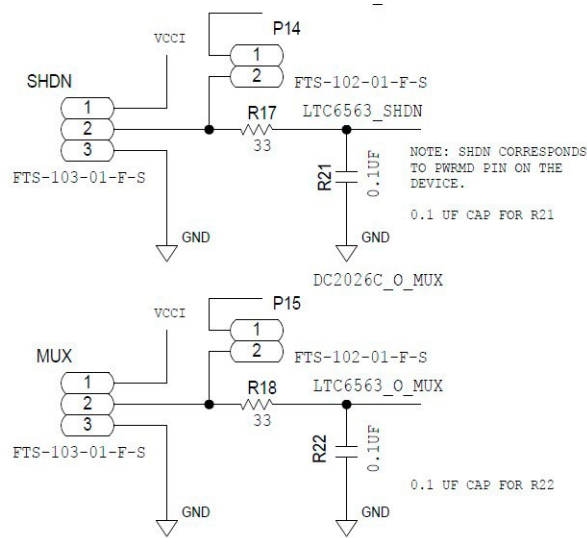

Figure 13. Channel Select Options

EQUIPMENT LIST

A. Demo Board Kit Contents:

1. LTC6563 EVAL Board.
2. SDP-K1 Microcontroller (plugged onto the bottom of the LTC6563 EVAL board): [Find information here.](#)
3. USB Cable

B. Dual-channel oscilloscope (e.g. Keysight MSO-X 6004A, or equivalent).

C. 905nm optical light source such as:

- Light Source (ST Micro): https://www.st.com/content/st_com/en/products/ecosystems/stm32-open-development-environment/stm32-nucleo-expansion-boards/stm32-ode-sense-hw/x-nucleo-5310a1.html
- Controller (requires programming): https://www.st.com/content/st_com/en/products/evaluation-tools/product-evaluation-tools/mcu-mpu-eval-tools/stm32-mcu-mpu-eval-tools/stm32-nucleo-boards/nucleo-f401re.html

D. Windows PC (WIN 10)

E. Coolterm (or equivalent) serial port terminal application download: https://download.cnet.com/CoolTerm/3000-2094_4-10915882.html

F. High-Voltage APD Bias DC Power Supply (HP6209B or equivalent) capable of at least 120V.

G. SMA to BNC coax cables (2 each) of similar length.

DEMO MANUAL EVAL-LTC6563-TQFN

SCHEMATIC DIAGRAM

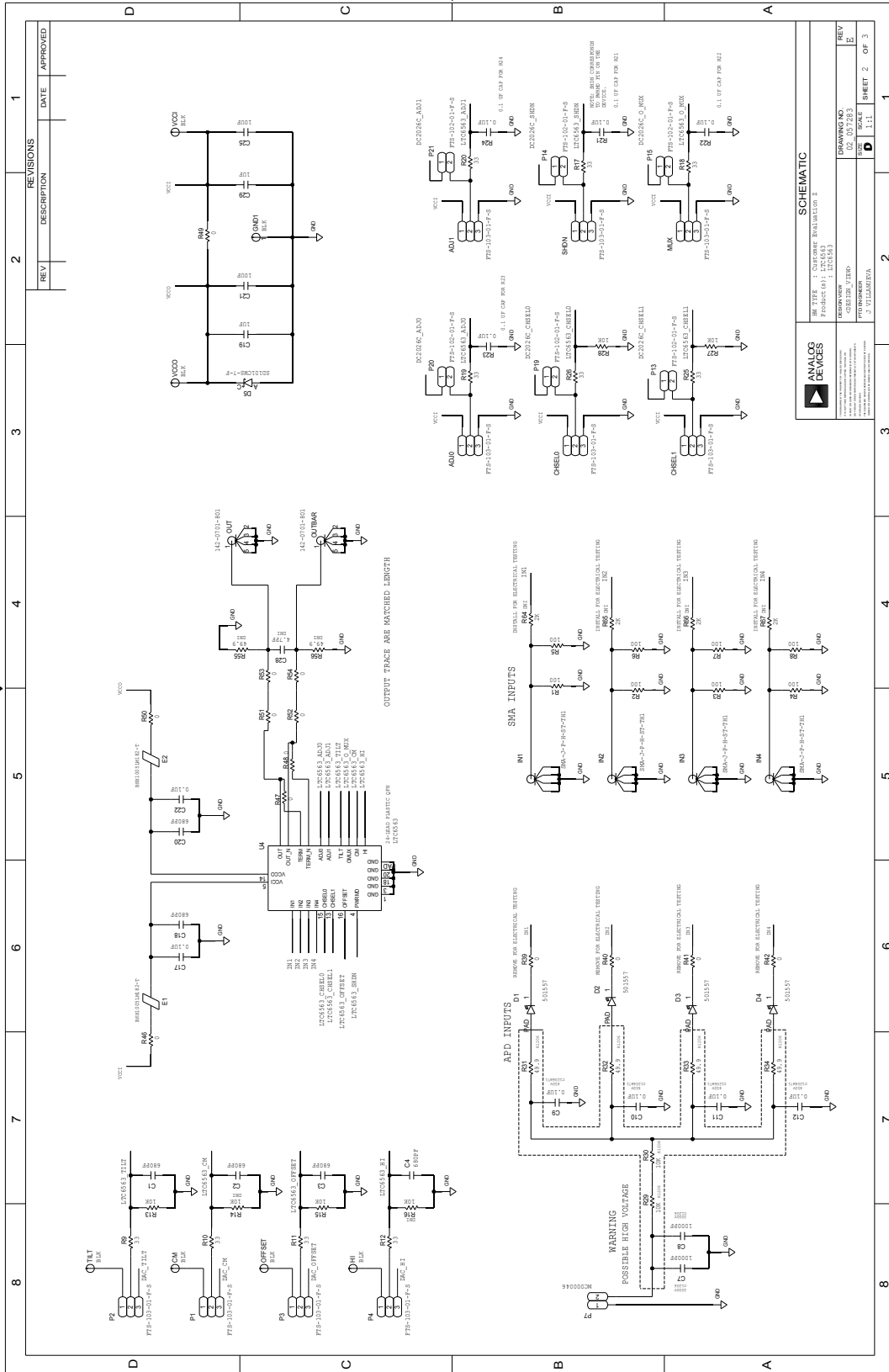

SCHEMATIC DIAGRAM

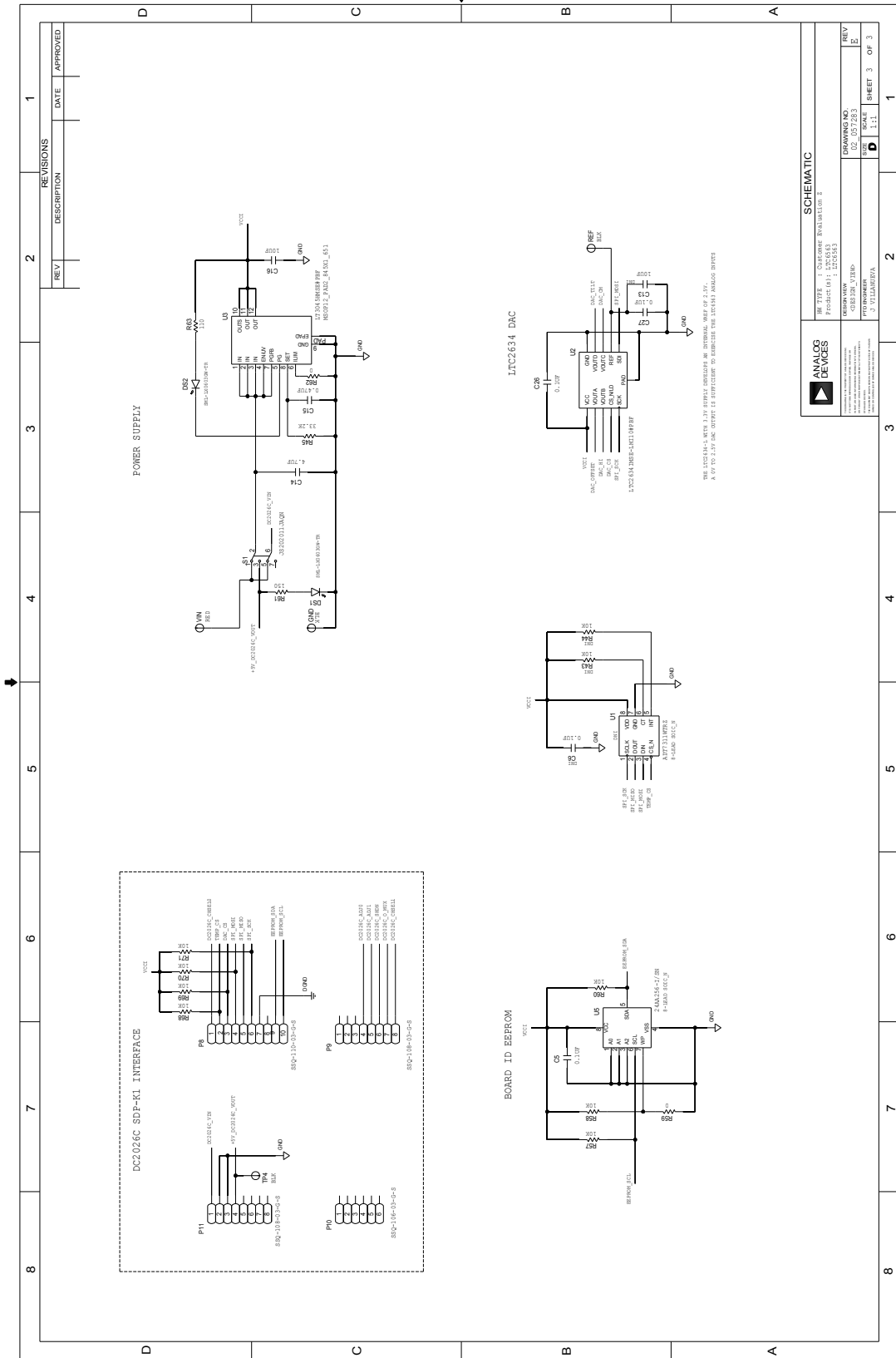

REV	DESCRIPTION	DATE	APPROVED
1			

SCHEMATIC	
REV	1.1
DATE	02/05/2013
DRAWING NO.	1302634
PRODUCT NO.	LTC2634
DESIGNER	ANALOG DEVICES
PROJ. NO.	1302634
SCALE	1:1
SHEET 3	OF 3



ESD Caution

ESD (electrostatic discharge) sensitive device. Charged devices and circuit boards can discharge without detection. Although this product features patented or proprietary protection circuitry, damage may occur on devices subjected to high energy ESD. Therefore, proper ESD precautions should be taken to avoid performance degradation or loss of functionality.

Legal Terms and Conditions

By using the evaluation board discussed herein (together with any tools, components documentation or support materials, the "Evaluation Board"), you are agreeing to be bound by the terms and conditions set forth below ("Agreement") unless you have purchased the Evaluation Board, in which case the Analog Devices Standard Terms and Conditions of Sale shall govern. Do not use the Evaluation Board until you have read and agreed to the Agreement. Your use of the Evaluation Board shall signify your acceptance of the Agreement. This Agreement is made by and between you ("Customer") and Analog Devices, Inc. ("ADI"), with its principal place of business at One Technology Way, Norwood, MA 02062, USA. Subject to the terms and conditions of the Agreement, ADI hereby grants to Customer a free, limited, personal, temporary, non-exclusive, non-sublicensable, non-transferable license to use the Evaluation Board FOR EVALUATION PURPOSES ONLY. Customer understands and agrees that the Evaluation Board is provided for the sole and exclusive purpose referenced above, and agrees not to use the Evaluation Board for any other purpose. Furthermore, the license granted is expressly made subject to the following additional limitations: Customer shall not (i) rent, lease, display, sell, transfer, assign, sublicense, or distribute the Evaluation Board; and (ii) permit any Third Party to access the Evaluation Board. As used herein, the term "Third Party" includes any entity other than ADI, Customer, their employees, affiliates and in-house consultants. The Evaluation Board is NOT sold to Customer; all rights not expressly granted herein, including ownership of the Evaluation Board, are reserved by ADI. CONFIDENTIALITY. This Agreement and the Evaluation Board shall all be considered the confidential and proprietary information of ADI. Customer may not disclose or transfer any portion of the Evaluation Board to any other party for any reason. Upon discontinuation of use of the Evaluation Board or termination of this Agreement, Customer agrees to promptly return the Evaluation Board to ADI. ADDITIONAL RESTRICTIONS. Customer may not disassemble, decompile or reverse engineer chips on the Evaluation Board. Customer shall inform ADI of any occurred damages or any modifications or alterations it makes to the Evaluation Board, including but not limited to soldering or any other activity that affects the material content of the Evaluation Board. Modifications to the Evaluation Board must comply with applicable law, including but not limited to the RoHS Directive. TERMINATION. ADI may terminate this Agreement at any time upon giving written notice to Customer. Customer agrees to return to ADI the Evaluation Board at that time. LIMITATION OF LIABILITY. THE EVALUATION BOARD PROVIDED HEREUNDER IS PROVIDED "AS IS" AND ADI MAKES NO WARRANTIES OR REPRESENTATIONS OF ANY KIND WITH RESPECT TO IT. ADI SPECIFICALLY DISCLAIMS ANY REPRESENTATIONS, ENDORSEMENTS, GUARANTEES, OR WARRANTIES, EXPRESS OR IMPLIED, RELATED TO THE EVALUATION BOARD INCLUDING, BUT NOT LIMITED TO, THE IMPLIED WARRANTY OF MERCHANTABILITY, TITLE, FITNESS FOR A PARTICULAR PURPOSE OR NON-INFRINGEMENT OF INTELLECTUAL PROPERTY RIGHTS. IN NO EVENT WILL ADI AND ITS LICENSORS BE LIABLE FOR ANY INCIDENTAL, SPECIAL, INDIRECT, OR CONSEQUENTIAL DAMAGES RESULTING FROM CUSTOMER'S POSSESSION OR USE OF THE EVALUATION BOARD, INCLUDING BUT NOT LIMITED TO LOST PROFITS, DELAY COSTS, LABOR COSTS OR LOSS OF GOODWILL. ADI'S TOTAL LIABILITY FROM ANY AND ALL CAUSES SHALL BE LIMITED TO THE AMOUNT OF ONE HUNDRED US DOLLARS (\$100.00). EXPORT. Customer agrees that it will not directly or indirectly export the Evaluation Board to another country, and that it will comply with all applicable United States federal laws and regulations relating to exports. GOVERNING LAW. This Agreement shall be governed by and construed in accordance with the substantive laws of the Commonwealth of Massachusetts (excluding conflict of law rules). Any legal action regarding this Agreement will be heard in the state or federal courts having jurisdiction in Suffolk County, Massachusetts, and Customer hereby submits to the personal jurisdiction and venue of such courts. The United Nations Convention on Contracts for the International Sale of Goods shall not apply to this Agreement and is expressly disclaimed.