

NOTE:

- MATERIAL AND FINISH
SHELL ASSEMBLY: COPPER ALLOY, OUTER SHELL AND COLLECT NUT Cr PLATING, OTHER METALLIC COMPONENTS Ni PLATING.
INSULATOR: PEEK
CONTACT: COPPER ALLOY, GOLD PLATING OVER Ni
- DURABILITY: 5000 CYCLES
- PROTECTION INDEX(MATED): IP66/IP68, IP68 ACHIEVED PROVIDING THAT THE CABLE IS PERFECTLY CIRCULAR AND THAT ASSEMBLY PROCESS ENSURES A HIGH INTEGRITY SEAL.
- HUMIDITY: UP TO 95% AT 60°C
- TEMPERATURE: -55°C,+200°C
- RoHS COMPLIANCE.
- PART NO.:

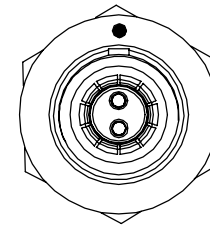
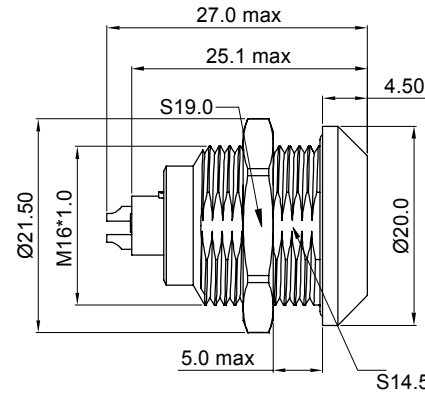
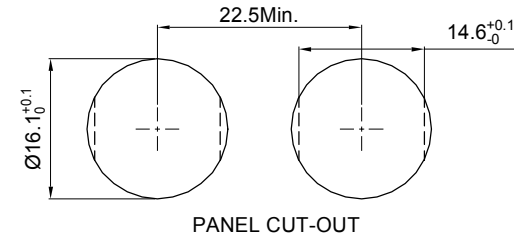

R - F 1 K R * * 0 * 0 0 * 0 0

CONTACT POS.	02-16=2pin-16pin
SHELL MATERIAL	0=Brass

CODE	KEY ANGLES
0	0
A	30°
B	60°
..	..

CODE	CONTACT TYPE
2	Male Solder Contact
4	Female Solder Contact



UNITS: ■ mm □ inch	SIZE A3	NAME: Snap Latch Metal 1KR Fixed Socket	
GENERAL TOLERANCE: (UNLESS SPECIFIED)		PART NO: R-F1KR**0*00*00	TITLE: CUSTOMER DWG
4 PLACE ± ** ±. **	3 PLACE ± ** ±. **	APPD: Ken張永 2019/11/27	DWG NO: 010-0000-B35
2 PLACE ± 0.3 ±. **	1 PLACE ± 0.5 ±. **	CHKD: Ken張永 2019/11/27	C
ANGLES X° ± 5°		DRAW: Ellen孫郁婷 2019/11/18	
		DESIGN: Cayley梁思雅 2019/11/18	SCALE SHEET REV. 2/1 1/5 B2

REV.	DESCRIPTION	DATE
B2	UPDATE DWG	11/13'19
B1	DIMENSION REVEISE	06/25'18

CONFIDENTIAL: THIS DOCUMENT CONTAINED THE INFORMATION IS PROPRIETARY AND CONFIDENTIAL TO Nexttronics Engineering Corp. NO PERSON IS ALLOWED TO USE COPY, PUBLISH OR OTHERWISE DISCLOSE THE INFORMATION TO OTHERS, UNLESS BY THE PRIOR WRITTEN EXPRESS AUTHORIZATION OF Nexttronics Engineering Corp. (C)COPYRIGHT- Nexttronics Engineering Corp.

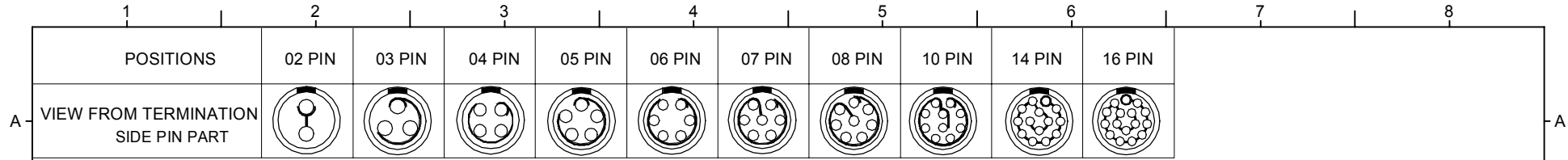

NOTE:

- MATERIAL AND FINISH
SHELL ASSEMBLY: COPPER ALLOY, OUTER SHELL AND COLLECT NUT Cr PLATING, OTHER METALLIC COMPONENTS Ni PLATING.
INSULATOR: PEEK
CONTACT: COPPER ALLOY, GOLD PLATING OVER Ni
- DURABILITY: 5000 CYCLES
- PROTECTION INDEX(MATED): IP66/IP68, IP68 ACHIEVED PROVIDING THAT THE CABLE IS PERFECTLY CIRCULAR AND THAT ASSEMBLY PROCESS ENSURES A HIGH INTEGRITY SEAL.
- HUMIDITY: UP TO 95% AT 60°C
- TEMPERATURE: -55°C,+200°C
- RoHS COMPLIANCE.
- PART NO.:

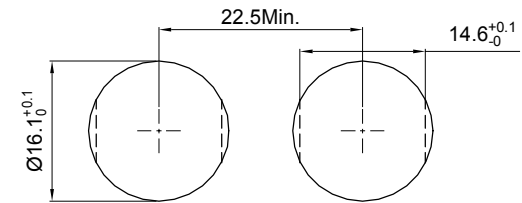

PANEL CUT-OUT

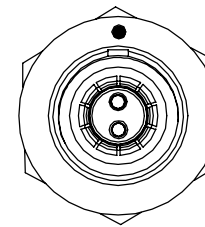
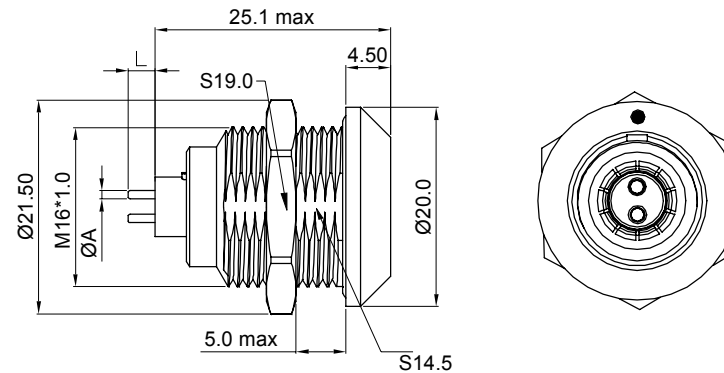

R - F 1 K R * * 0 * 0 0 * 0 0

CONTACT POS.	02-16=2pin-16pin
SHELL MATERIAL	0=Brass

CODE	KEY ANGLES
0	0
A	30°
B	60°
..	..

CODE	CONTACT TYPE
1	Male Print Contact
3	Female Print Contact



REV.	DESCRIPTION	DATE
B2	UPDATE DWG	11/13'19
B1	DIMENSION REVEISE	06/25'18

UNITS: ■ mm □ inch	SIZE A3	NAME: Snap Latch Metal 1KR Fixed Socket	 NEXTRONICS ENGINEERING CORP.						
GENERAL TOLERANCE: (UNLESS SPECIFIED)		PART NO: R-F1KR**0*00*00		TITLE: CUSTOMER DWG					
4 PLACE ± ** ±. **	3 PLACE ± ** ±. **	APPD: Ken張永 2019/11/27	DWG NO: 010-0000-B35						
2 PLACE ± 0.3 ±. **	1 PLACE ± 0.5 ±. **	CHKD: Ken張永 2019/11/27	<table border="1"> <tr> <td>SCALE</td> <td>SHEET</td> <td>REV.</td> </tr> <tr> <td>2/1</td> <td>2/5</td> <td>B2</td> </tr> </table>	SCALE	SHEET	REV.	2/1	2/5	B2
SCALE	SHEET	REV.							
2/1	2/5	B2							
ANGLES X° ± 5°		DRAW: Ellen孫郁婷 2019/11/18							
		DESIGN: Cayley梁思雅 2019/11/18							

CONFIDENTIAL: THIS DOCUMENT CONTAINED THE INFORMATION IS PROPRIETARY AND CONFIDENTIAL TO Nexttronics Engineering Corp. NO PERSON IS ALLOWED TO USE COPY, PUBLISH OR OTHERWISE DISCLOSE THE INFORMATION TO OTHERS, UNLESS BY THE PRIOR WRITTEN EXPRESS AUTHORIZATION OF Nexttronics Engineering Corp. (C)COPYRIGHT- Nexttronics Engineering Corp.

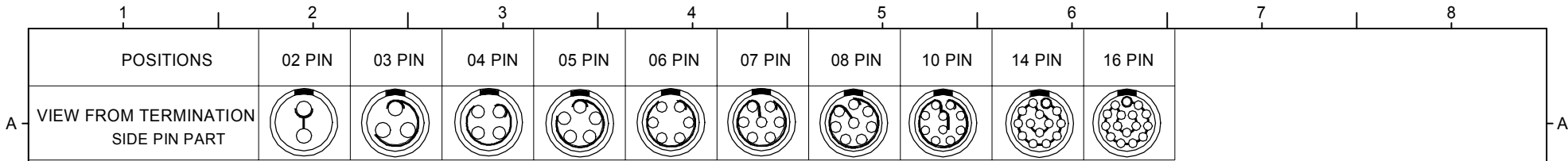

NOTE:

- MATERIAL AND FINISH
SHELL ASSEMBLY: COPPER ALLOY, OUTER SHELL AND COLLECT NUT Cr PLATING, OTHER METALLIC COMPONENTS Ni PLATING.
INSULATOR: PEEK
CONTACT: COPPER ALLOY, GOLD PLATING OVER Ni
- DURABILITY: 5000 CYCLES
- PROTECTION INDEX(MATED): IP66/IP68, IP68 ACHIEVED PROVIDING THAT THE CABLE IS PERFECTLY CIRCULAR AND THAT ASSEMBLY PROCESS ENSURES A HIGH INTEGRITY SEAL.
- HUMIDITY: UP TO 95% AT 60°C
- TEMPERATURE: -55°C,+200°C
- RoHS COMPLIANCE.
- PART NO.:

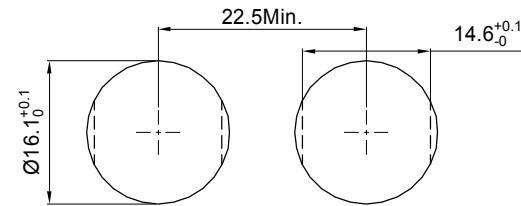

PANEL CUT-OUT

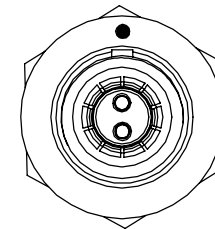
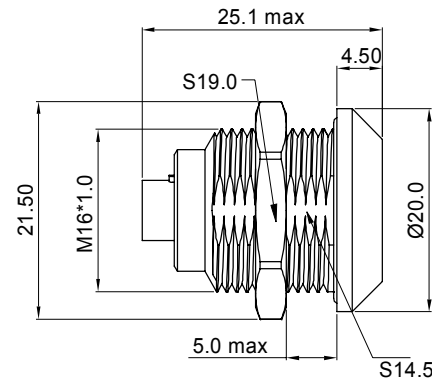

R - F 1 K R ** 0 * 0 0 * 0 0

CONTACT POS.
02-16=2pin-16pin

SHELL MATERIAL
0=Brass

CODE	CONTACT TYPE
C	Crimp Male Contact
M	Crimp Female Contact

CODE	KEY ANGLES
0	0
A	30°
B	60°
..	..



UNITS: ■ mm □ inch	SIZE A3	NAME: Snap Latch Metal 1KR Fixed Socket	 NEXTRONICS ENGINEERING CORP.							
GENERAL TOLERANCE: (UNLESS SPECIFIED)		PART NO: R-F1KR**0*00*00	TITLE: CUSTOMER DWG							
4 PLACE	± **	APPD: Ken張永 2019/11/27	DWG NO: 010-0000-B35							
3 PLACE	± **	CHKD: Ken張永 2019/11/27	<table border="1"> <tr> <td>SCALE</td> <td>SHEET</td> <td>REV.</td> </tr> <tr> <td>2/1</td> <td>3/5</td> <td>B2</td> </tr> </table>		SCALE	SHEET	REV.	2/1	3/5	B2
SCALE	SHEET	REV.								
2/1	3/5	B2								
2 PLACE	± 0.3	DRAW: Ellen孫郁婷 2019/11/18								
1 PLACE	± 0.5	DESIGN: Cayley梁思雅 2019/11/18								
ANGLES	X° ± 5°									

REV.	DESCRIPTION	DATE
B2	UPDATE DWG	11/13'19
B1	DIMENSION REVEISE	06/25'18

1 2 3 4 5 6 7 8

A KEY ANGLES (RECEPTACLE FRONT VIEW): A

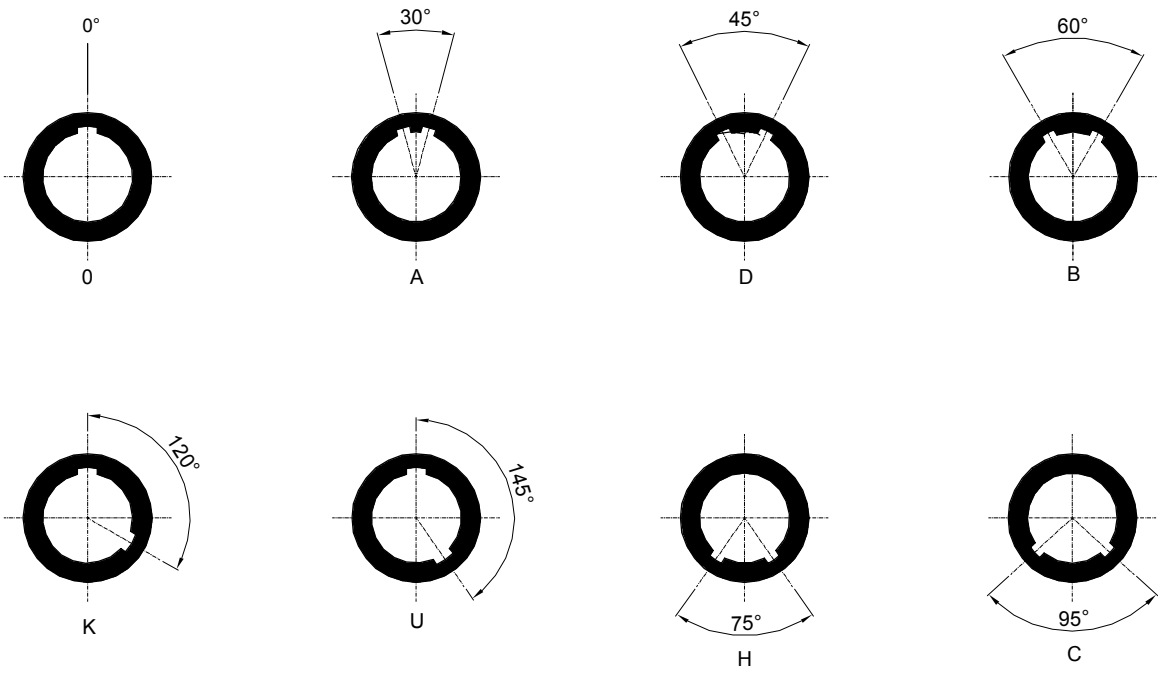

C C

D D

ENGINEERING CORPORATION
 NEXTRONICS
 ISSUE DATE
 2019/11/28
nexttron
 This file is automatically issued by EPDM and is not valid without the issue date

B2	UPDATE DWG	11/13'19
B1	DIMENSION REVEISE	06/25'18
REV.	DESCRIPTION	DATE

UNITS: ■ mm □ inch	SIZE A3	NAME: Snap Latch Metal 1KR Fixed Socket	 NEXTRONICS ENGINEERING CORP.
GENERAL TOLERANCE: (UNLESS SPECIFIED)		PART NO: R-F1KR**0*00*00	
4 PLACE ± **	mm ± **	inch ± **	APPD: Ken張永 2019/11/27
3 PLACE ± **	mm ± **	inch ± **	CHKD: Ken張永 2019/11/27
2 PLACE ± 0.3	mm ± 0.3	inch ± **	DRAW: Ellen孫郁婷 2019/11/18
1 PLACE ± 0.5	mm ± 0.5	inch ± **	DESIGN: Cayley梁思雅 2019/11/18
ANGLES X°± 5°			DWG NO: 010-0000-B35 SCALE SHEET REV. 2/1 4/5 B2

CONFIDENTIAL: THIS DOCUMENT CONTAINED THE INFORMATION IS PROPRIETARY AND CONFIDENTIAL TO Nextronics Engineering Corp. NO PERSON IS ALLOWED TO USE COPY, PUBLISH OR OTHERWISE DISCLOSE THE INFORMATION TO OTHERS, UNLESS BY THE PRIOR WRITTEN EXPRESS AUTHORIZATION OF Nextronics Engineering Corp. (C)COPYRIGHT- Nextronics Engineering Corp.

PCB DRILLING PATTERN:

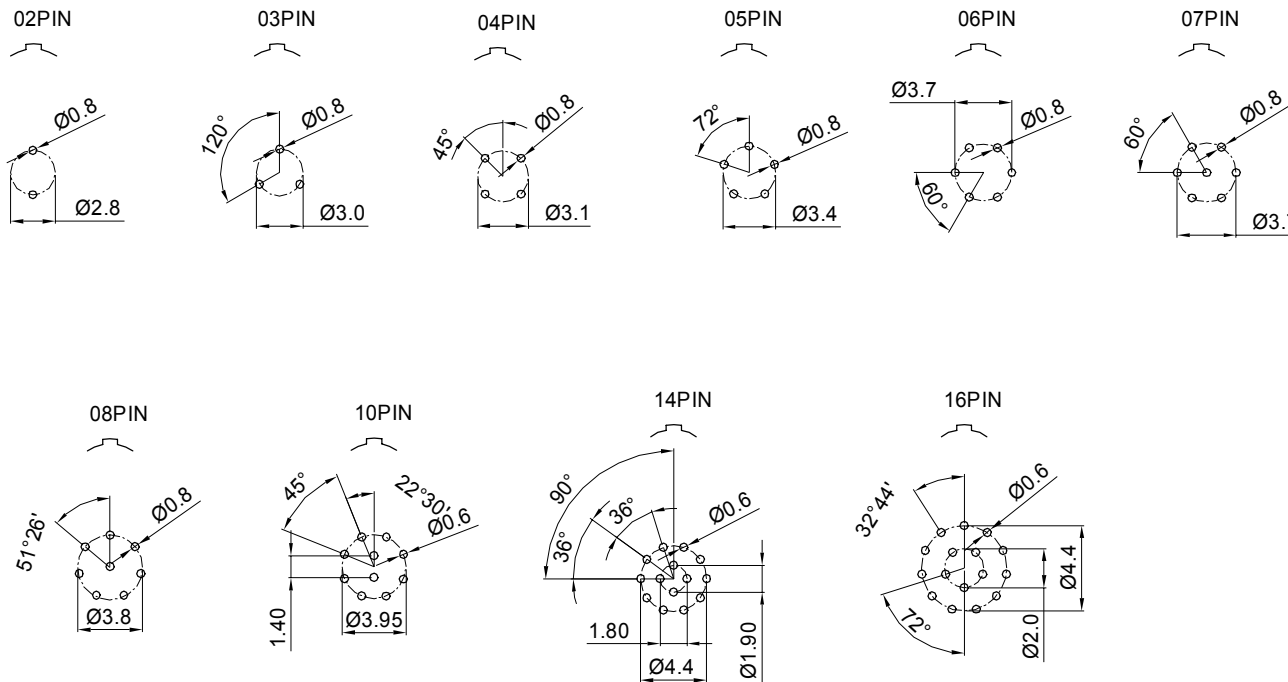

UNITS: ■ mm □ inch	SIZE A3	NAME: Snap Latch Metal 1KR Fixed Socket	 NEXTRONICS ENGINEERING CORP.			
GENERAL TOLERANCE: (UNLESS SPECIFIED)		PART NO: R-F1KR**0*00*00			TITLE: CUSTOMER DWG	
4 PLACE	± **	± **	APPD: Ken張永	2019/11/27	DWG NO: 010-0000-B35	C
3 PLACE	± **	± **	CHKD: Ken張永	2019/11/27		
2 PLACE	± 0.3	± **	DRAW: Ellen孫郁婷	2019/11/18	SCALE SHEET REV. 2/1 5/5 B2	
1 PLACE	± 0.5	± **	DESIGN: Cayley梁思雅	2019/11/18		
ANGLES	X° ± 5°					

B2	UPDATE DWG	11/13'19
B1	DIMENSION REVEISE	06/25'18
REV.	DESCRIPTION	DATE

CONFIDENTIAL: THIS DOCUMENT CONTAINED THE INFORMATION IS PROPRIETARY AND CONFIDENTIAL TO Nextronics Engineering Corp. NO PERSON IS ALLOWED TO USE COPY, PUBLISH OR OTHERWISE DISCLOSE THE INFORMATION TO OTHERS, UNLESS BY THE PRIOR WRITTEN EXPRESS AUTHORIZATION OF Nextronics Engineering Corp. (C)COPYRIGHT- Nextronics Engineering Corp.