



CD22100

CMOS 4 x 4 Crosspoint Switch with Control Memory High-Voltage Type (20V Rating)

March 1993

Features

- Low ON Resistance 75Ω Typ. at $V_{DD} = 12V$
- "Built-In" Control Latches
- Large Analog Signal Capability $\pm V_{DD}/2$
- 10MHz Switch Bandwidth
- Matched Switch Characteristics $\Delta R_{ON} = 18\Omega$ Typ. at $V_{DD} = 12V$
- High Linearity - 0.5% Distortion (Typ.) at $f = 1kHz$, $V_{IN} = 5V_{P-P}$, $V_{DD} = 10V$, and $R_L = 1k\Omega$
- Standard CMOS Noise Immunity
- 100% Tested for Maximum Quiescent Current at 20V

Description

CD22100 combines a 4 x 4 array of crosspoints (transmission gates) with a 4-line to 16-line decoder and 16 latch circuits. Any one of the sixteen transmission gates (crosspoints) can be selected by applying the appropriate four line address. The selected transmission gate can be turned on or off by applying a logical one or zero, respectively, to the data input and strobing the strobe input to a logical one. Any number of the transmission gates can be ON simultaneously. When the required operating power is applied to the CD22100, the states of the 16 switches are indeterminate. Therefore, all switches must be turned off by putting the strobe high and data in low, and then addressing all switches in succession.

Ordering Information

PART NUMBER	TEMPERATURE RANGE	PACKAGE
CD22100D	-55°C to +125°C	16 Lead Ceramic Sidebrazed DIP
CD22100E	-40°C to +85°C	16 Lead Plastic DIP
CD22100F	-55°C to +125°C	16 Lead Ceramic Frit Seal DIP

Pinout

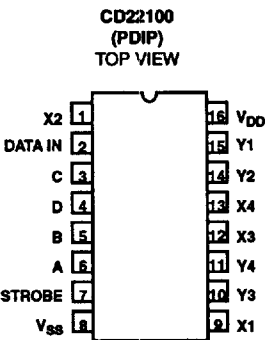

Functional Diagram

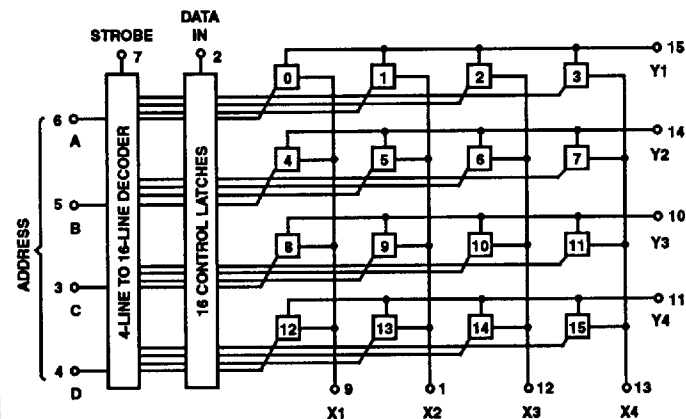

Absolute Maximum Ratings

Supply Voltage
 (Voltages Referenced to V_{SS} Terminal) -0.5 to +20V
 Input Voltage (All Inputs) -0.5 to $V_{DD} + 0.5V$
 Input Current (Any one input (Note 1)) $\pm 10mA$
 Power Dissipation
 For $T_A = -40^\circ C$ to $+60^\circ C$ (Package Type E) 500mW
 For $T_A = +60^\circ C$ to $+85^\circ C$
 (Package Type E) Derate Linearly 12mW/ $^\circ C$ to 200mW
 For $T_A = -55^\circ C$ to $+100^\circ C$ (Package Type D, F) 500mW
 For $T_A = +100^\circ C$ to $+125^\circ C$
 (Package Type D, F) Derate Linearly 12mW/ $^\circ C$ to 200mW
 Device Dissipation per Transmission Gate
 For $T_A =$ Full Package Temperature Range (All Types) 100mW
 Junction Temperature $+175^\circ C$
 Junction Temperature (Plastic Package) $+150^\circ C$
 Lead Temperature (Soldering 10 Sec.) $+300^\circ C$

Recommended Operating Conditions

Operating Temperature Range
 Package Type D and F $-55^\circ C \leq T_A \leq +125^\circ C$
 Package Type E $-40^\circ C \leq T_A \leq +85^\circ C$
 Storage Temperature Range $-65^\circ C \leq T_A \leq +150^\circ C$
 Supply Voltage Range
 For $T_A =$ Full Package Temperature Range $+3V$ to $+18V$

CAUTION: Stresses above those listed in "Absolute Maximum Ratings" may cause permanent damage to the device. This is a stress only rating and operation of the device at these or any other conditions above those indicated in the operational sections of this specification is not implied.

Static Electrical Specifications Values at $-55^\circ C$, $+25^\circ C$, $+125^\circ C$ Apply to D, F, H Packages
 Values at $-40^\circ C$, $+25^\circ C$, $+85^\circ C$ Apply to E Package

PARAMETERS	SYMBOL	TEST CONDITIONS	LIMITS AT INDICATED TEMPERATURES								UNITS	
			FIG.	V_{DD} (V)	$-55^\circ C$	$-40^\circ C$	$+85^\circ C$	$+125^\circ C$	$+25^\circ C$			
									MIN	TYP		MAX
CROSSPOINTS												
Quiescent Device Current	I_{DD} Max.		1	5	5	5	150	150	-	0.04	5	μA
			1	10	10	10	300	300	-	0.04	10	μA
			1	15	20	20	600	600	-	0.04	20	μA
			1	20	100	100	3000	3000	-	0.08	100	μA
On Resistance	R_{ON} Max.	Any Switch $V_{IS} = 0$ to V_{DD}	11	5	475	500	725	800	-	225	600	Ω
			12	10	135	145	205	230	-	85	180	Ω
			-	12	100	110	155	175	-	75	135	Ω
			13	15	70	75	110	125	-	65	95	Ω
ΔR_{ON} Resistance	ΔR_{ON}	Between any two switches	-	5	-	-	-	-	-	25	-	Ω
			-	10	-	-	-	-	-	10	-	Ω
			-	12	-	-	-	-	-	8	-	Ω
			-	15	-	-	-	-	-	5	-	Ω
Off Switch Leakage Current	I_L Max.	All switches OFF, $V_{IS} = 18V$	3	18	± 100		± 1000		-	± 1	± 100 (Note 2)	nA
CONTROLS												
Input Low Voltage	V_{IL} Max.	OFF switch $I_L < 0.2\mu A$	-	5	1.5			-	-	1.5	V	
			-	10	3			-	-	3	V	
			-	15	4			-	-	4	V	
Input High Voltage	V_{IH} Min.	ON switch see R_{ON} characteristic	-	5	3.5			3.5	-	-	V	
			-	10	7			7	-	-	V	
			-	15	11			11	-	-	V	
Input Current	I_{IN} Max.	Any control $V_{IN} = 0, 18V$	2	18	± 0.1	± 0.1	± 1	± 1	-	$\pm 10^{-5}$	± 0.1	μA

NOTES:

1. Maximum current through transmission gates (switches) = 25mA.
2. Determined by minimum feasible leakage measurement for automatic testing.

Specifications CD22100

Dynamic Electrical Specifications $T_A = +25^\circ\text{C}$

PARAMETERS	SYMBOL	FIGURE	TEST CONDITIONS				LIMITS			UNITS
			f_{IS} (kHz)	R_L (k Ω)	V_{IS} (V) (Note 1)	V_{DD} (V)	MIN	TYP	MAX	
CROSSPOINTS										
Propagation Delay Time, (Switch ON) Signal Input to Output	t_{PHL}, t_{PLH}	5	-	10	5	5	-	30	60	ns
					10	10	-	15	30	ns
					15	15	-	10	20	ns
$C_L = 50\text{pF}; t_R, t_F = 20\text{ns}$										
Frequency Response (Any switch ON)	f_{3dB}	16	1	1	5	10	-	40	-	MHz
			Sine wave input, $20 \log \frac{V_{OS}}{V_{IS}} = -3\text{dB}$							
Sine Wave Response (Distortion)	T_{HD}		1	1	5	10	-	0.5	-	%
Feedthrough (All switches OFF)	F_{DT}		1.6	1	5	10	-	-80	-	dB
			Sine wave input							
Frequency for Signal Crosstalk Attenuation of 40dB	F_{CT}	7	-	1	10	10	-	1.5	-	MHz
			Sine wave input							
Attenuation of 110dB							-	0.1	-	kHz
Capacitance:	C_{IS}									
Xn to Ground				-	-	5 - 15	-	18	-	pF
Yn to Ground				-	-	5 - 15	-	30	-	pF
Feedthrough	C_{IOS}						-	0.4	-	pF
CONTROLS										
Propagation Delay Time: Strobe to Output (Switch Turn-ON to High Level)	t_{PZH}	8	$R_L = 1\text{k}\Omega,$ $C_L = 50\text{pF},$ $t_R, t_F = 20\text{ns}$			5	-	300	600	ns
						10	-	125	250	ns
						15	-	80	160	ns
Propagation Delay Time: Data-In to Output (Turn-On to High Level)	t_{PZH}	9	$R_L = 1\text{k}\Omega,$ $C_L = 50\text{pF},$ $t_R, t_F = 20\text{ns}$			5	-	110	220	ns
						10	-	40	80	ns
						15	-	25	50	ns
Propagation Delay Time: Address to Output (Turn-ON to High Level)	t_{PZH}	10	$R_L = 1\text{k}\Omega,$ $C_L = 50\text{pF},$ $t_R, t_F = 20\text{ns}$			5	-	350	700	ns
						10	-	135	270	ns
						15	-	90	180	ns
Propagation Delay Time: Strobe to Output (Switch Turn-OFF)	t_{PHZ}	8	$R_L = 1\text{k}\Omega,$ $C_L = 50\text{pF},$ $t_R, t_F = 20\text{ns}$			5	-	165	330	ns
						10	-	85	170	ns
						15	-	70	140	ns
Propagation Delay Time: Data-In to Output (Turn-ON to Low Level)	t_{PZL}	9	$R_L = 1\text{k}\Omega,$ $C_L = 50\text{pF},$ $t_R, t_F = 20\text{ns}$			5	-	210	420	ns
						10	-	110	220	ns
						15	-	100	200	ns
Propagation Delay Time: Address to Output (Turn-OFF)	t_{PHZ}	10	$R_L = 1\text{k}\Omega,$ $C_L = 50\text{pF},$ $t_R, t_F = 20\text{ns}$			5	-	435	870	ns
						10	-	210	420	ns
						15	-	160	320	ns

8 TELECOM

Specifications CD22100

Dynamic Electrical Specifications $T_A = +25^\circ\text{C}$ (Continued)

PARAMETERS	SYMBOL	FIGURE	TEST CONDITIONS				LIMITS			UNITS
			f_{is} (kHz)	R_L (k Ω)	V_{is} (V) (Note 1)	V_{DD} (V)	MIN	TYP	MAX	
Minimum Setup Time Data-In to Strobe, Address	t_s	8, 10	$R_L = 1\text{k}\Omega$, $C_L = 50\text{pF}$, $t_R, t_F = 20\text{ns}$			5	-	95	190	ns
						10	-	25	50	ns
						15	-	15	30	ns
Minimum Hold Time Data-In to Strobe, Address	t_H	8, 10	$R_L = 1\text{k}\Omega$, $C_L = 50\text{pF}$, $t_R, t_F = 20\text{ns}$			5	-	180	360	ns
						10	-	110	220	ns
						15	-	35	70	ns
Maximum Switching Frequency	f_{θ}		$R_L = 1\text{k}\Omega$, $C_L = 50\text{pF}$, $t_R, t_F = 20\text{ns}$			5	0.6	1.2	-	MHz
						10	1.6	3.2	-	MHz
						15	2.5	5	-	MHz
Minimum Strobe Pulse Width	t_W	8				5	-	300	600	ns
						10	-	120	240	ns
						15	-	90	180	ns
Control Crosstalk, Data-In, Address or Strobe to Output		6	Square wave input; $t_R, t_F = 20\text{ns}$			10	-	75	-	mV (peak)
			-	10	10					
Input Capacitance	C_{IN}		Any Control Input			-	-	5	7.5	pF

NOTE:

1. Peak-to-peak voltage symmetrical about $\frac{V_{DD}}{2}$.

Schematic Diagram

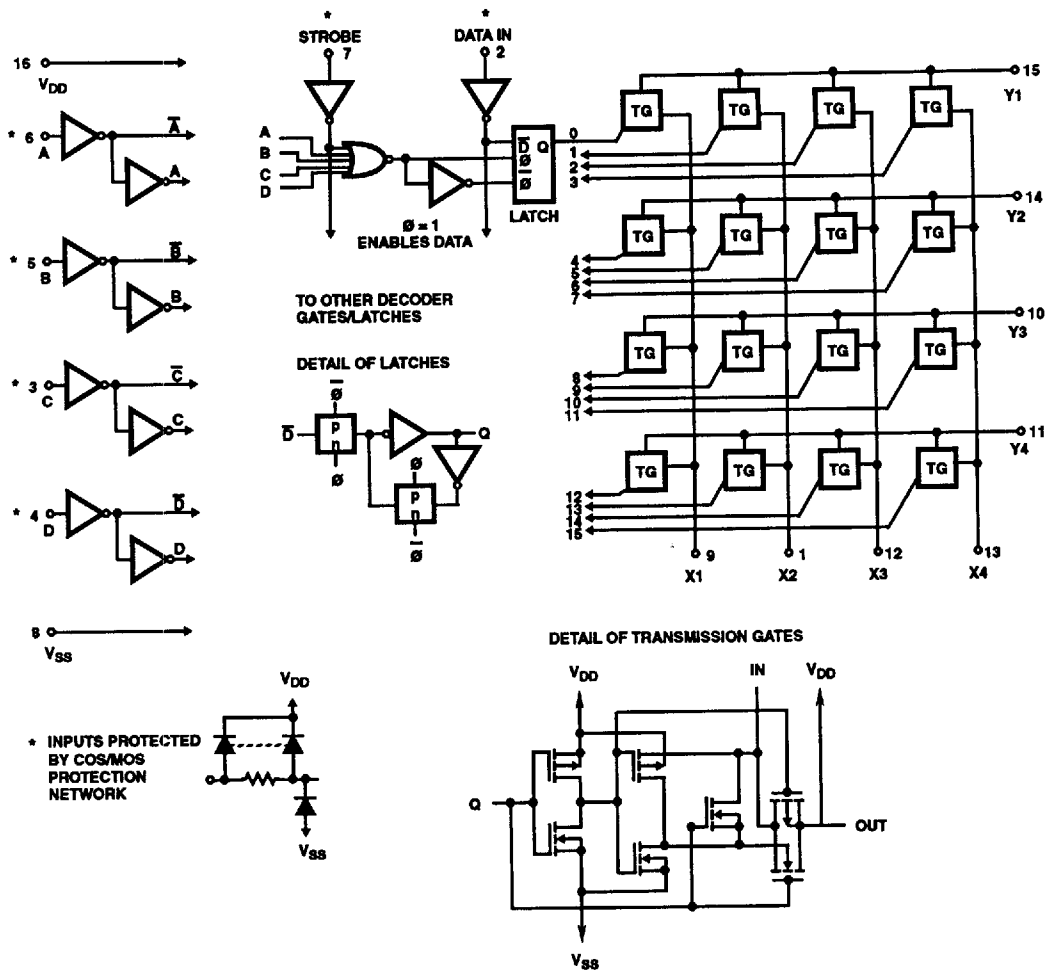

TRUTH TABLE

ADDRESS				SELECT	ADDRESS				SELECT
A	B	C	D		A	B	C	D	
0	0	0	0	X1Y1	0	0	0	1	X1Y3
1	0	0	0	X2Y1	1	0	0	1	X2Y3
0	1	0	0	X3Y1	0	1	0	1	X3Y3
1	1	0	0	X4Y1	1	1	0	1	X4Y3
0	0	1	0	X1Y2	0	0	1	1	X1Y4
1	0	1	0	X2Y2	1	0	1	1	X2Y4
0	1	1	0	X3Y2	0	1	1	1	X3Y4
1	1	1	0	X4Y2	1	1	1	1	X4Y4

Metallization Mask Layout

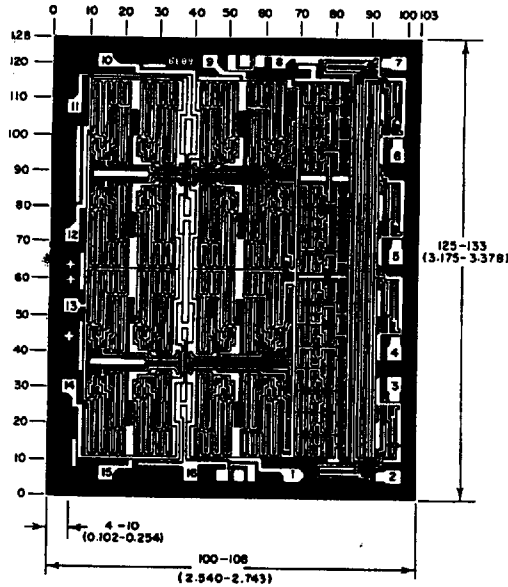

Dimensions in parenthesis are in millimeters and are derived from the basic inch dimensions as indicated. Grid graduations are in mils (10^{-3} inch).

Test Circuits and Waveforms

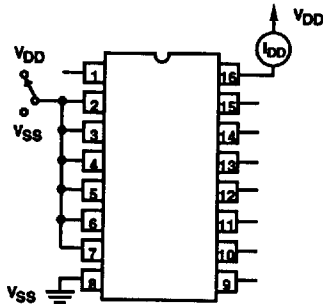

FIGURE 1. QUIESCENT CURRENT TEST CIRCUIT

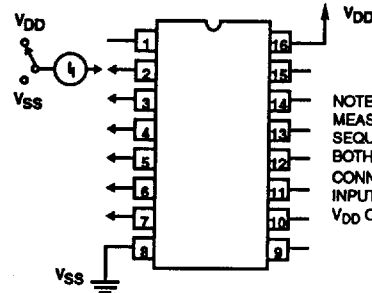

FIGURE 2. INPUT CURRENT TEST CIRCUIT

NOTE:
MEASURE INPUTS
SEQUENTIALLY TO
BOTH V_{DD} AND V_{SS}
CONNECT ALL UNUSED
INPUTS TO EITHER
 V_{DD} OR V_{SS}

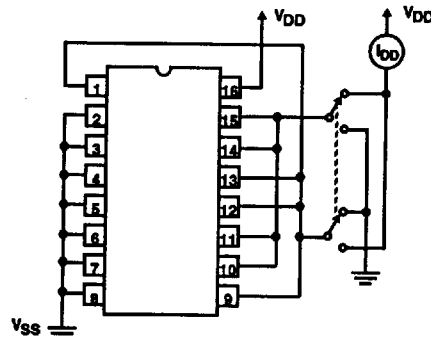
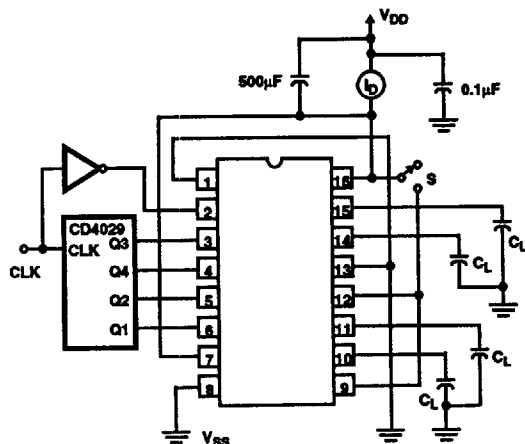

FIGURE 3. OFF SWITCH INPUT OR OUTPUT LEAKAGE CURRENT TEST CIRCUIT

Test Circuits and Waveforms (Continued)



NOTE:
CLOSE SWITCH S AFTER APPLYING V_{DD}

FIGURE 4. DYNAMIC POWER DISSIPATION TEST CIRCUIT AND TYPICAL DYNAMIC POWER DISSIPATION AS A FUNCTION OF SWITCHING FREQUENCY

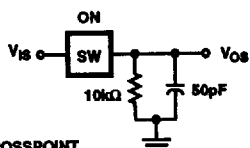
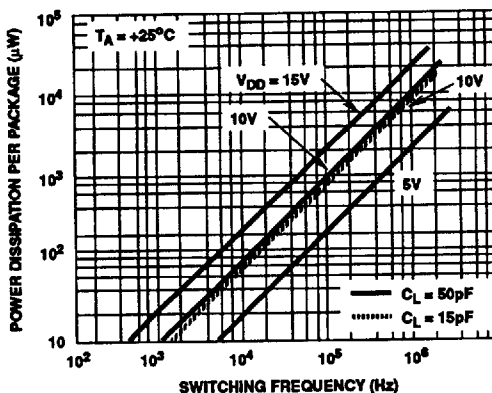

SW = ANY CROSSPOINT
STROBE = DATA - IN = V_{DD}

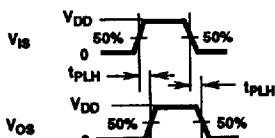
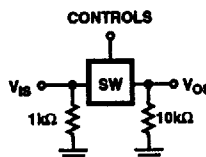

FIGURE 5. PROPAGATION DELAY TIME TEST CIRCUIT AND WAVEFORMS (SIGNAL INPUT TO SIGNAL OUTPUT, SWITCH ON)



SW = ANY CROSSPOINT

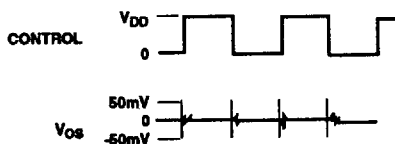
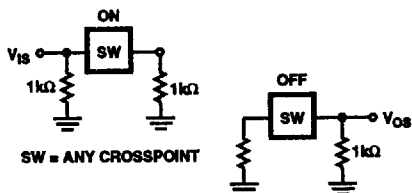

FIGURE 6. TEST CIRCUIT AND WAVEFORMS FOR CROSSTALK (CONTROL INPUT TO SIGNAL OUTPUT)



SW = ANY CROSSPOINT

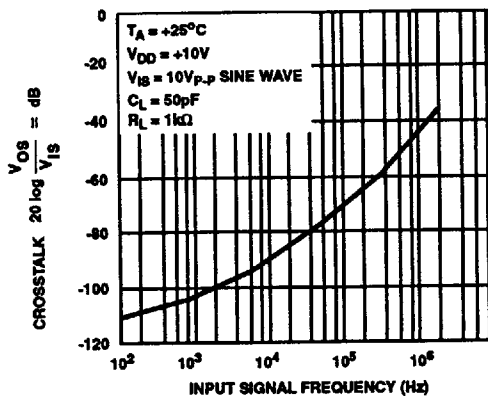

FIGURE 7. TEST CIRCUIT AND TYPICAL CROSSTALK BETWEEN SWITCH CIRCUITS IN THE SAME PACKAGE AS A FUNCTION OF SIGNAL FREQUENCY

Test Circuits and Waveforms (Continued)

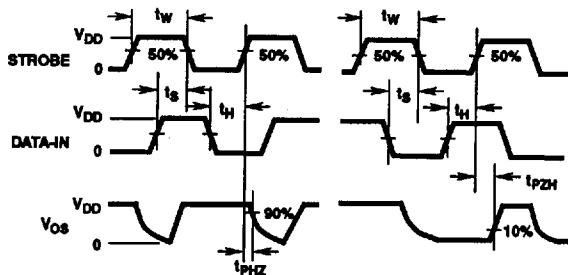
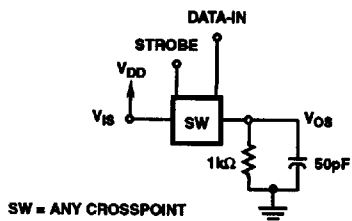

FIGURE 8. PROPAGATION DELAY TIME TEST CIRCUIT AND WAVEFORMS (STROBE TO SIGNAL OUTPUT, SWITCH TURN-ON OR TURN-OFF)

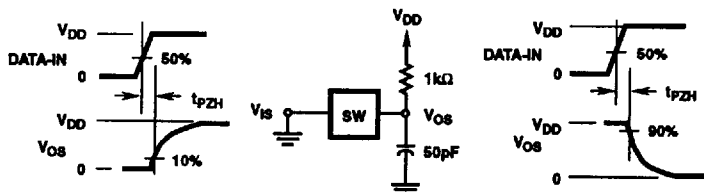
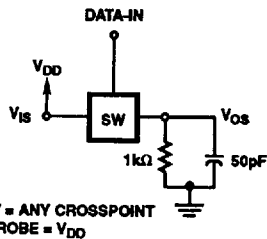

FIGURE 9. PROPAGATION DELAY TIME TEST CIRCUIT AND WAVEFORMS (DATA-IN TO SIGNAL OUTPUT, SWITCH TURN-ON TO HIGH OR LOW LEVEL)

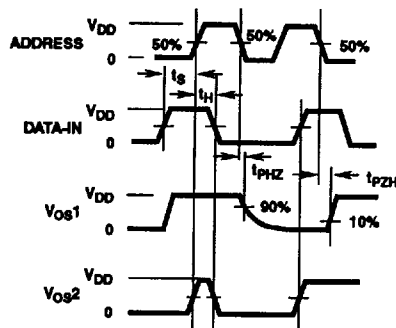
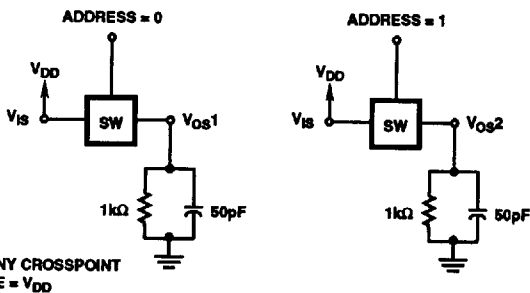

FIGURE 10. PROPAGATION DELAY TIME TEST CIRCUIT AND WAVEFORMS (ADDRESS TO SIGNAL OUTPUT, SWITCH TURN-ON OR TURN-OFF)

Typical Performance Curves

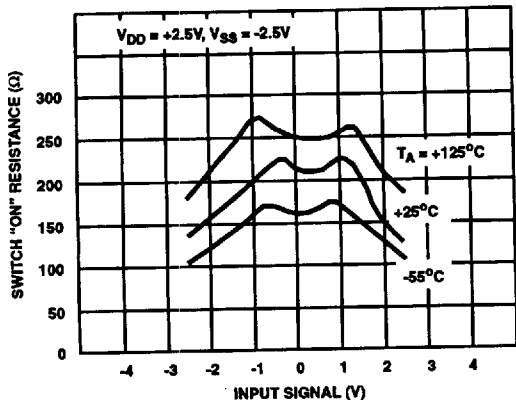

FIGURE 11. TYPICAL ON RESISTANCE AS A FUNCTION OF INPUT SIGNAL VOLTAGE AT $V_{DD} = -V_{SS} = 2.5V$

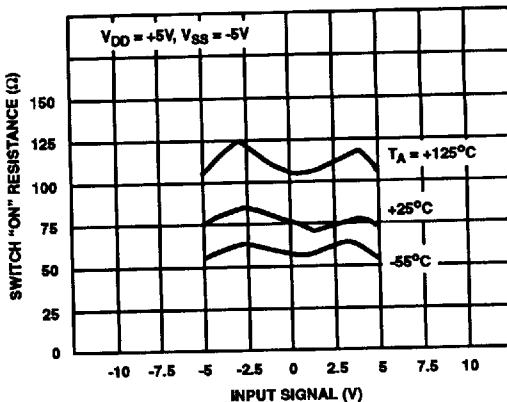

FIGURE 12. TYPICAL ON RESISTANCE AS A FUNCTION OF INPUT SIGNAL VOLTAGE AT $V_{DD} = -V_{SS} = 5V$

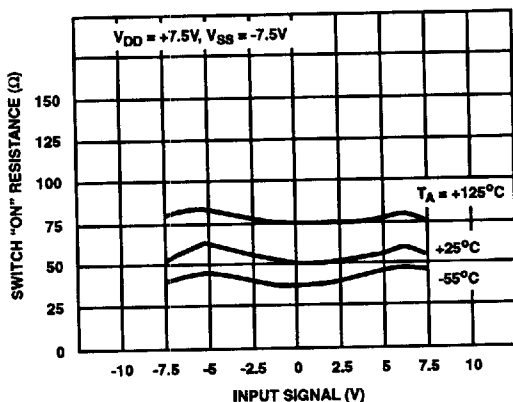

FIGURE 13. TYPICAL ON RESISTANCE AS A FUNCTION OF INPUT SIGNAL VOLTAGE AT $V_{DD} = -V_{SS} = 7.5V$

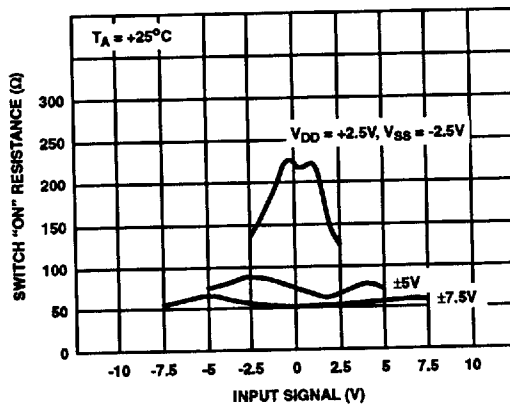

FIGURE 14. TYPICAL ON RESISTANCE AS A FUNCTION OF INPUT SIGNAL VOLTAGE AT $T_A = +25^\circ C$

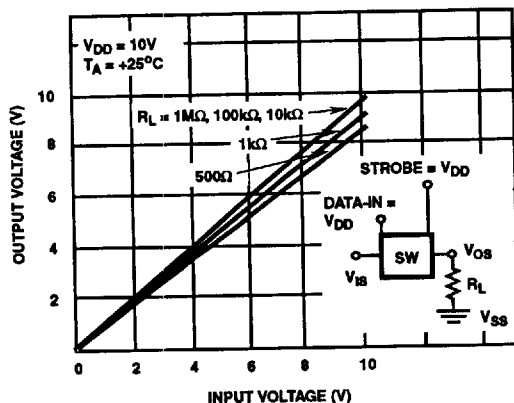

FIGURE 15. TYPICAL SWITCH ON TRANSFER CHARACTERISTICS (1 OF 16 SWITCHES)

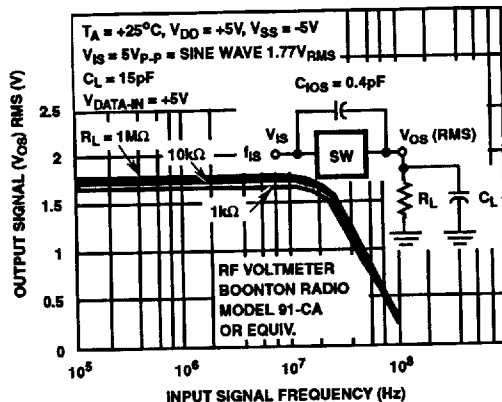

FIGURE 16. TYPICAL SWITCH ON FREQUENCY RESPONSE CHARACTERISTICS