

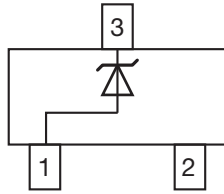

Small Signal Zener Diodes



FEATURES

- Silicon planar Zener diodes
- Standard Zener voltage tolerance is $\pm 5\%$
- AEC-Q101 qualified available (part number on request)
- ESD capability according to AEC-Q101:
Human body model > 8 kV
Machine model > 800 V
- Base P/N-G3 - green, commercial grade
- Material categorization:
for definitions of compliance please see www.vishay.com/doc?99912



DESIGN SUPPORT TOOLS

[click logo to get started](#)



PRIMARY CHARACTERISTICS		
PARAMETER	VALUE	UNIT
V _Z range nom.	2.4 to 43	V
Test current I _{ZT}	0.05	mA
V _Z specification	Pulse current	
Circuit configuration	Single	

ORDERING INFORMATION			
DEVICE NAME	ORDERING CODE	TAPED UNITS PER REEL	MINIMUM ORDER QUANTITY
MMBZ4681-G to MMBZ4717-G	MMBZ4681-G3-08 to MMBZ4717-G3-08	3000 (8 mm tape on 7" reel)	15 000
	MMBZ4681-G3-18 to MMBZ4717-G3-18	10 000 (8 mm tape on 13" reel)	10 000

PACKAGE				
PACKAGE NAME	WEIGHT	MOLDING COMPOUND FLAMMABILITY RATING	MOISTURE SENSITIVITY LEVEL	SOLDERING CONDITIONS
SOT-23	8.8 mg	UL 94 V-0	MSL level 1 (according J-STD-020)	260 °C/10 s at terminals

ABSOLUTE MAXIMUM RATINGS (T _{amb} = 25 °C, unless otherwise specified)				
PARAMETER	TEST CONDITION	SYMBOL	VALUE	UNIT
Power dissipation	On FR - 5 board using recommended solder pad layout	P _{tot}	350	mW
Zener current	See table "Electrical Characteristics"			
Thermal resistance junction to ambient air	On FR - 5 board using recommended solder pad layout	R _{thJA}	420	K/W
Junction temperature, maximum		T _j	150	°C
Storage temperature range		T _{stg}	-55 to +150	°C
Operating temperature range		T _{op}	-55 to +150	°C



ELECTRICAL CHARACTERISTICS ($T_{amb} = 25\text{ }^{\circ}\text{C}$, unless otherwise specified)								
PART NUMBER	MARKING CODE	ZENER VOLTAGE RANGE ⁽¹⁾			TEST CURRENT	REVERSE CURRENT		VOLTAGE CHANGE ⁽²⁾
		V_Z at I_{ZT1}			I_{ZT1}	I_R at V_R		ΔV_Z
		V			mA	μA	V	V
		MIN.	NOM.	MAX.		MAX.		MAX.
MMBZ4681-G	TF	2.28	2.4	2.52	0.05	2	1	0.8
MMBZ4682-G	TH	2.57	2.7	2.84	0.05	1	1	0.85
MMBZ4683-G	TJ	2.85	3	3.15	0.05	0.8	1	0.9
MMBZ4684-G	TK	3.14	3.3	3.47	0.05	7.5	1.5	0.95
MMBZ4685-G	TM	3.42	3.6	3.78	0.05	7.5	2	0.95
MMBZ4686-G	TN	3.71	3.9	4.1	0.05	5	2	0.97
MMBZ4687-G	TP	4.09	4.3	4.52	0.05	4	2	0.99
MMBZ4688-G	TT	4.47	4.7	4.94	0.05	10	3	0.99
MMBZ4689-G	TU	4.85	5.1	5.36	0.05	10	3	0.97
MMBZ4690-G	TV	5.32	5.6	5.88	0.05	10	4	0.96
MMBZ4691-G	TA	5.89	6.2	6.51	0.05	10	5	0.95
MMBZ4692-G	TX	6.46	6.8	7.14	0.05	10	5.1	0.9
MMBZ4693-G	TY	7.13	7.5	7.88	0.05	10	5.7	0.75
MMBZ4694-G	TZ	7.79	8.2	8.61	0.05	1	6.2	0.5
MMBZ4695-G	UC	8.27	8.7	9.14	0.05	1	6.6	0.1
MMBZ4696-G	UD	8.65	9.1	9.56	0.05	1	6.9	0.08
MMBZ4697-G	UE	9.5	10	10.5	0.05	1	7.6	0.1
MMBZ4698-G	UF	10.5	11	11.6	0.05	0.05	8.4	0.11
MMBZ4699-G	UH	11.4	12	12.6	0.05	0.05	9.1	0.12
MMBZ4700-G	UJ	12.4	13	13.7	0.05	0.05	9.8	0.13
MMBZ4701-G	UK	13.3	14	14.7	0.05	0.05	10.6	0.14
MMBZ4702-G	UM	14.3	15	15.8	0.05	0.05	11.4	0.15
MMBZ4703-G	UN	15.2	16	16.8	0.05	0.05	12.1	0.16
MMBZ4704-G	UP	16.2	17	17.9	0.05	0.05	12.9	0.17
MMBZ4705-G	UT	17.1	18	18.9	0.05	0.05	13.6	0.18
MMBZ4706-G	UU	18.1	19	20	0.05	0.05	14.4	0.19
MMBZ4707-G	UV	19	20	21	0.05	0.01	15.2	0.2
MMBZ4708-G	UA	20.9	22	23.1	0.05	0.01	16.7	0.22
MMBZ4709-G	UZ	22.8	24	25.2	0.05	0.01	18.2	0.24
MMBZ4710-G	UY	23.8	25	26.3	0.05	0.01	19	0.25
MMBZ4711-G	ZA	25.7	27	28.4	0.05	0.01	20.4	0.27
MMBZ4712-G	ZC	26.6	28	29.4	0.05	0.01	21.2	0.28
MMBZ4713-G	ZD	28.5	30	31.5	0.05	0.01	22.8	0.3
MMBZ4714-G	ZE	31.4	33	34.7	0.05	0.01	25	0.33
MMBZ4715-G	ZF	34.2	36	37.8	0.05	0.01	27.3	0.36
MMBZ4716-G	ZH	37.1	39	41	0.05	0.01	29.6	0.39
MMBZ4717-G	ZJ	40.9	43	45.2	0.05	0.01	32.6	0.43

Notes

- Maximum $V_F = 0.9\text{ V}$, at $I_F = 10\text{ mA}$

⁽¹⁾ Tested with pulse test current

⁽²⁾ Maximum voltage change (V_Z). Voltage change is equal to the difference between V_Z at $100\text{ }\mu\text{A}$ and V_Z at $10\text{ }\mu\text{A}$.



PACKAGE DIMENSIONS in millimeters (inches): SOT-23

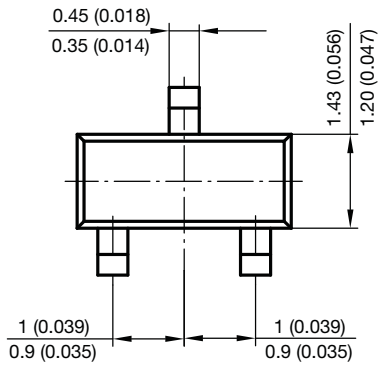
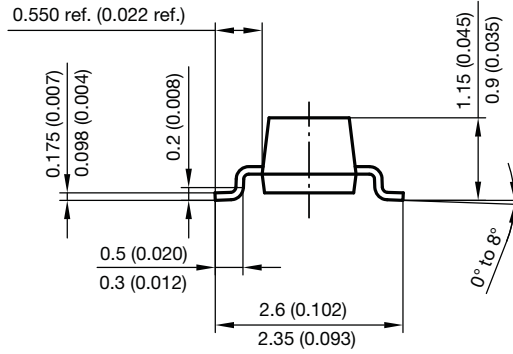
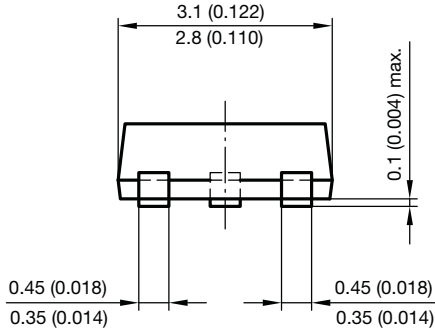

Foot print recommendation:

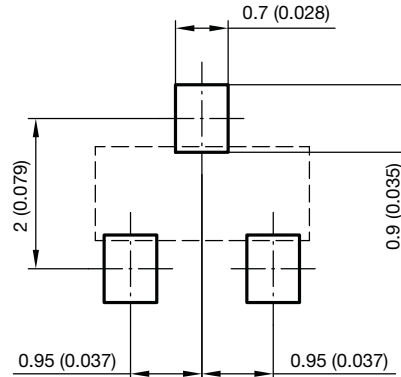

Document no.: 6.541-5014.01-4
Rev. 8 - Date: 23.Sept.2009
17418



Disclaimer

ALL PRODUCT, PRODUCT SPECIFICATIONS AND DATA ARE SUBJECT TO CHANGE WITHOUT NOTICE TO IMPROVE RELIABILITY, FUNCTION OR DESIGN OR OTHERWISE.

Vishay Intertechnology, Inc., its affiliates, agents, and employees, and all persons acting on its or their behalf (collectively, "Vishay"), disclaim any and all liability for any errors, inaccuracies or incompleteness contained in any datasheet or in any other disclosure relating to any product.

Vishay makes no warranty, representation or guarantee regarding the suitability of the products for any particular purpose or the continuing production of any product. To the maximum extent permitted by applicable law, Vishay disclaims (i) any and all liability arising out of the application or use of any product, (ii) any and all liability, including without limitation special, consequential or incidental damages, and (iii) any and all implied warranties, including warranties of fitness for particular purpose, non-infringement and merchantability.

Statements regarding the suitability of products for certain types of applications are based on Vishay's knowledge of typical requirements that are often placed on Vishay products in generic applications. Such statements are not binding statements about the suitability of products for a particular application. It is the customer's responsibility to validate that a particular product with the properties described in the product specification is suitable for use in a particular application. Parameters provided in datasheets and / or specifications may vary in different applications and performance may vary over time. All operating parameters, including typical parameters, must be validated for each customer application by the customer's technical experts. Product specifications do not expand or otherwise modify Vishay's terms and conditions of purchase, including but not limited to the warranty expressed therein.

Hyperlinks included in this datasheet may direct users to third-party websites. These links are provided as a convenience and for informational purposes only. Inclusion of these hyperlinks does not constitute an endorsement or an approval by Vishay of any of the products, services or opinions of the corporation, organization or individual associated with the third-party website. Vishay disclaims any and all liability and bears no responsibility for the accuracy, legality or content of the third-party website or for that of subsequent links.

Except as expressly indicated in writing, Vishay products are not designed for use in medical, life-saving, or life-sustaining applications or for any other application in which the failure of the Vishay product could result in personal injury or death. Customers using or selling Vishay products not expressly indicated for use in such applications do so at their own risk. Please contact authorized Vishay personnel to obtain written terms and conditions regarding products designed for such applications.

No license, express or implied, by estoppel or otherwise, to any intellectual property rights is granted by this document or by any conduct of Vishay. Product names and markings noted herein may be trademarks of their respective owners.