

SD-6482-1*

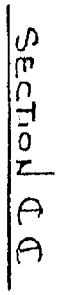
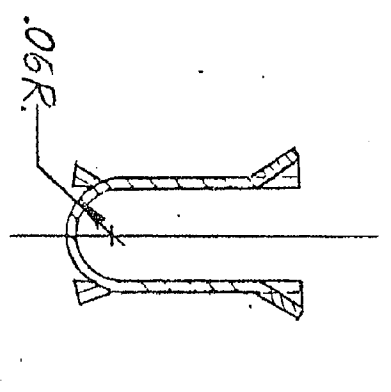
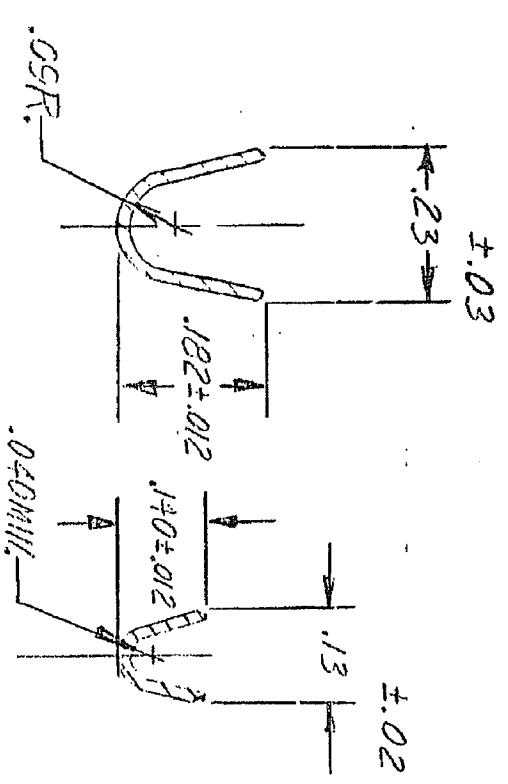
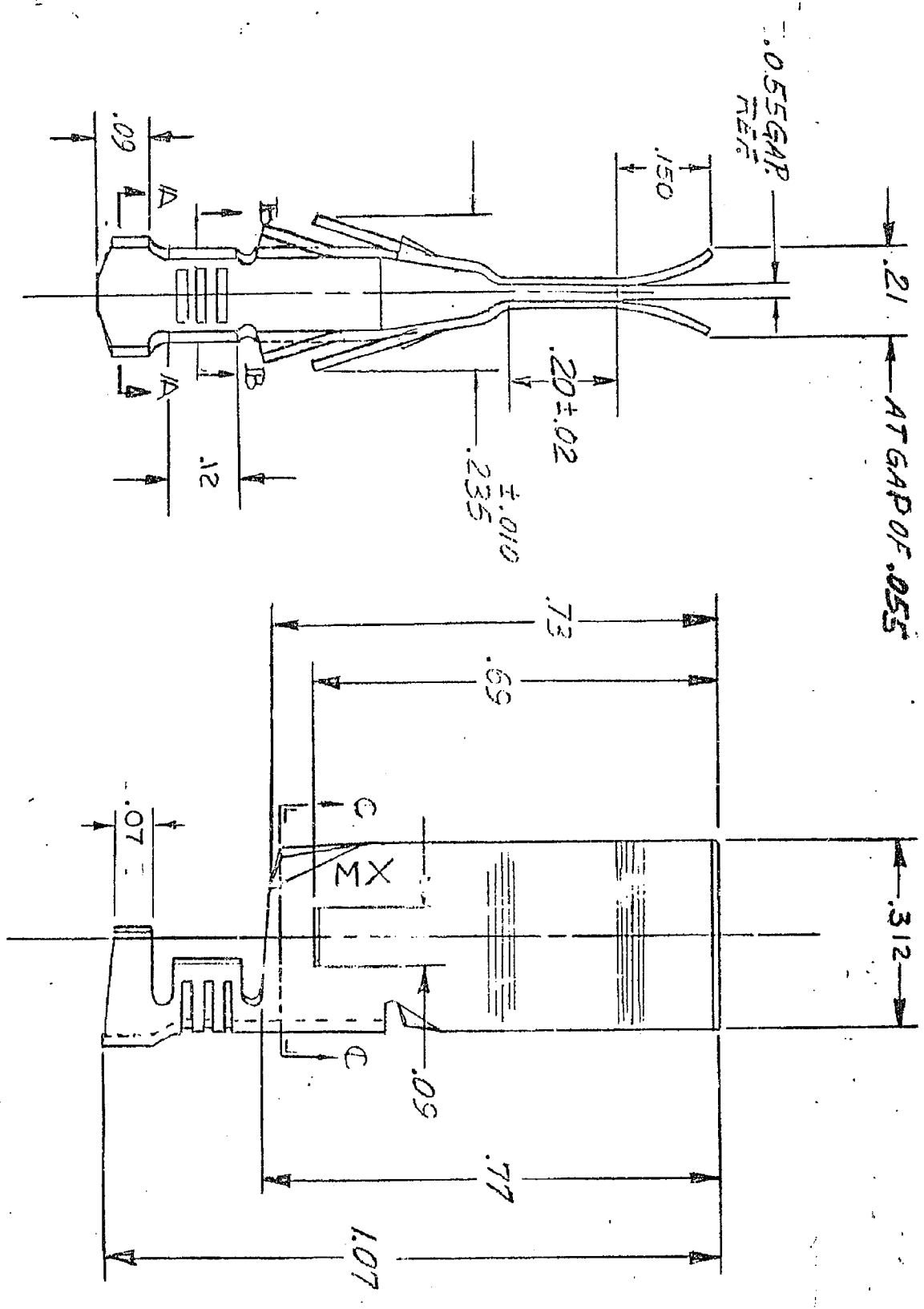

NOTES:
 ▲ FOR CRIMPING 14 TO 18 A.W.G. WIRE.

PART No	ENG No	DESCRIPTION
05-12-1102	6482-1	CHAIN

MATERIAL:
 BRONZE, HIGH TEMPERATURE, .016 THICK.

D	DELETE PART NO. ECR U2-1706 23-01-20 AG
C	.07 ADDED. ECR U8-2273 11-29-88 MB
B	REVISE MAT'L. CALL OUT BRONZE WAS BRASS # ADD EDP NO. TO 6482-1L ERO # 22731 6-12-86 JCS MB
A	ADD EDP # TO 6482-1 PER ERO # 19397 10-5-84 JCS
1	X-RELEASE PER ERO # 14276 10-12-81 JOK

REVISIONS

UNLESS OTHERWISE SPECIFIED
 TOLERANCES:
 3-PLACE DEC. DIMS ±.010
 2-PLACE DEC. DIMS ±.014
 ANGULAR ± 1/2°
 DRAFT WHEN APPLICABLE MUST REMAIN WITHIN DIRECTIONS, UNLESS OTHERWISE SPECIFIED.
 DO NOT SCALE DRAWING

TERMINAL
 MOLEX PRODUCTS CO.
 DOWNERS GROVE, ILL. 60515, U.S.A.
 DATE 10-12-81
 SD-6482-1*

THIS DRAWING CONTAINS INFORMATION THAT IS PROPRIETARY TO THE MOLEX PRODUCTS COMPANY AND SHOULD NOT BE USED WITHOUT WRITTEN PERMISSION.