

## 100mA, LOW NOISE LINEAR REGULATOR WITH PRECISION CURRENT LIMIT AND DIAGNOSTIC FUNCTIONS

### DESCRIPTION

Demonstration circuit 1515 is an adjustable 100mA linear regulator featuring LT<sup>®</sup>3050. LT3050 is a micro-power, low noise and low dropout voltage linear regulator. The device supplies 100mA of output current with a dropout voltage of 340mV. A 10nF bypass capacitor reduces output noise to  $30\mu\text{V}_{\text{RMS}}$  in a 10Hz to 100kHz bandwidth and soft-starts the reference. The LT3050's 45V input voltage rating combined with its precision current limit and diagnostic functions make the IC an ideal choice for robust, high reliability applications. The internal current limit should be considered when input-to-output differential is high. See the datasheet for details.

LT3050 current limit can be programmed by a single resistor, accurate to  $\pm 5\%$  over a wide input voltage and temperature range. A single resistor programs the LT3050's minimum output current monitor, useful for detecting open-circuit conditions. The current monitor function sources a current equal to  $1/100^{\text{th}}$  of output current. See the datasheet "Operation" section for detailed calculation. A logic FAULT pin asserts low

if the LT3050 is in current limit, operating below its minimum output current (open-circuit) or is in thermal shutdown. LT3050 optimizes the stability and transient response with low ESR ceramic cap, requiring a minimum of 2.2 $\mu\text{F}$ .

The LT3050 is available in the thermally-enhanced 12-Lead 3mm $\times$ 2mm DFN and MSOP packages.

The LT3050 datasheet gives a complete description of the part, operation and application information. The datasheet must be read in conjunction with this quick start guide for demo circuit 1515.

**Design files for this circuit board are available. Call the LTC factory.**

 , LTC and LT are registered trademarks of Linear Technology Corporation. All other trademarks are the property of their respective owners.

**Table 1. Performance Summary ( $T_A = 25^\circ\text{C}$ )**

PARAMETER	CONDITION	VALUE
Minimum Input Voltage	$V_{\text{OUT}}=5\text{V}$ , $I_{\text{OUT}}=100\text{mA}$	5.4V
Maximum Input Voltage	$V_{\text{OUT}}=5\text{V}$ , $I_{\text{OUT}}=90\text{mA}$	45V
Output Voltage $V_{\text{OUT}}$	Header in JP6	$4.99\text{V} \pm 2.8\%$
Maximum Output Current	$V_{\text{IN}}=12\text{V}$ , $V_{\text{OUT}}=5\text{V}$ , $R_{\text{IMAX}}=1.15\text{k}$	100mA
Minimum Output Current	$V_{\text{IN}}=12\text{V}$ , $V_{\text{OUT}}=5\text{V}$ , $R_{\text{IMAX}}=11.3\text{k}$	10mA
To $\mu\text{P}$ ADC Voltage	$V_{\text{IN}}=12\text{V}$ , $V_{\text{OUT}}=5\text{V}$ , $R_{\text{IMON}}=3.01\text{k}$ , $I_{\text{OUT}}=100\text{mA}$	2.98V

## QUICK START PROCEDURE

Demonstration circuit 1515 is easy to set up to evaluate the performance of the LT3050. Refer to Figure 1 for proper measurement equipment setup and follow the procedure below:

**NOTE:** Make sure that the input voltage does not exceed 45V.

**NOTE:** The shutdown jumper JP8 shunt is required to be placed in the OFF or ON position for proper operation.

**NOTE:** Place the output voltage selection jumper JP1-JP7 at the desired position.

**NOTE:** Do not hot-plug the input voltage terminal VIN. The absolute maximum voltage on VIN is 50V and hot-plugging a power supply through wire leads to the demonstration circuit can cause the voltage on the extremely low-ESR ceramic input capacitor to ring to twice its DC value. In order to protect the IC, a higher ESR Aluminum Electrolytic capacitor is placed at the input terminals. This may

protect against some, but not all, input transients due to hot-plugging with a power supply. *See Application Note 88 for more details.*

**NOTE:** Connect the power supply (with power off), load, and meters as shown in Figure 1.

1. After all connections are made, turn on input power and verify that the output voltage according to the output voltage selection jumper (JP1-JP7).

**NOTE:** If the output voltage is too low, temporarily disconnect the load to make sure that the load is not set too high.

2. Once the proper output voltages are established, adjust the load within the operating range and observe the output voltage regulation, efficiency and other parameters.

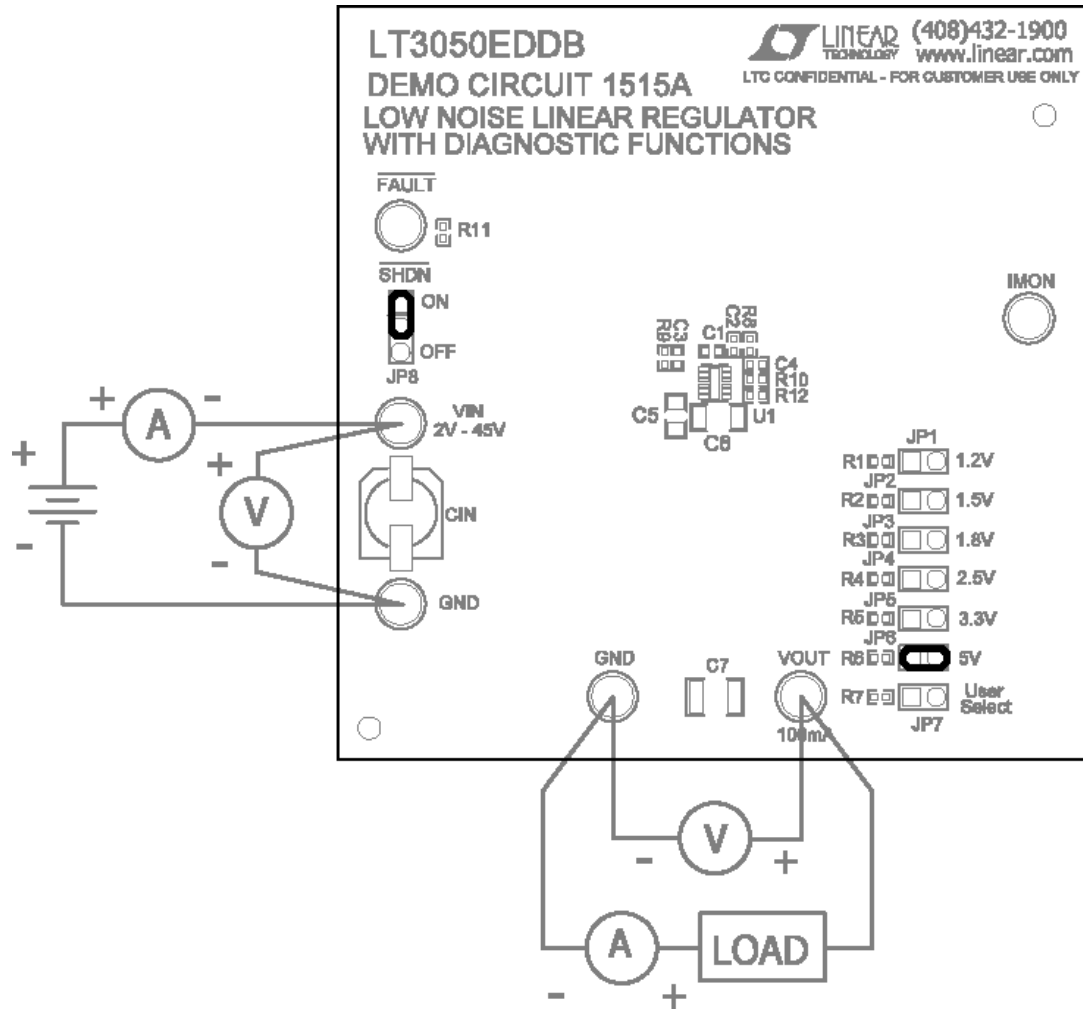
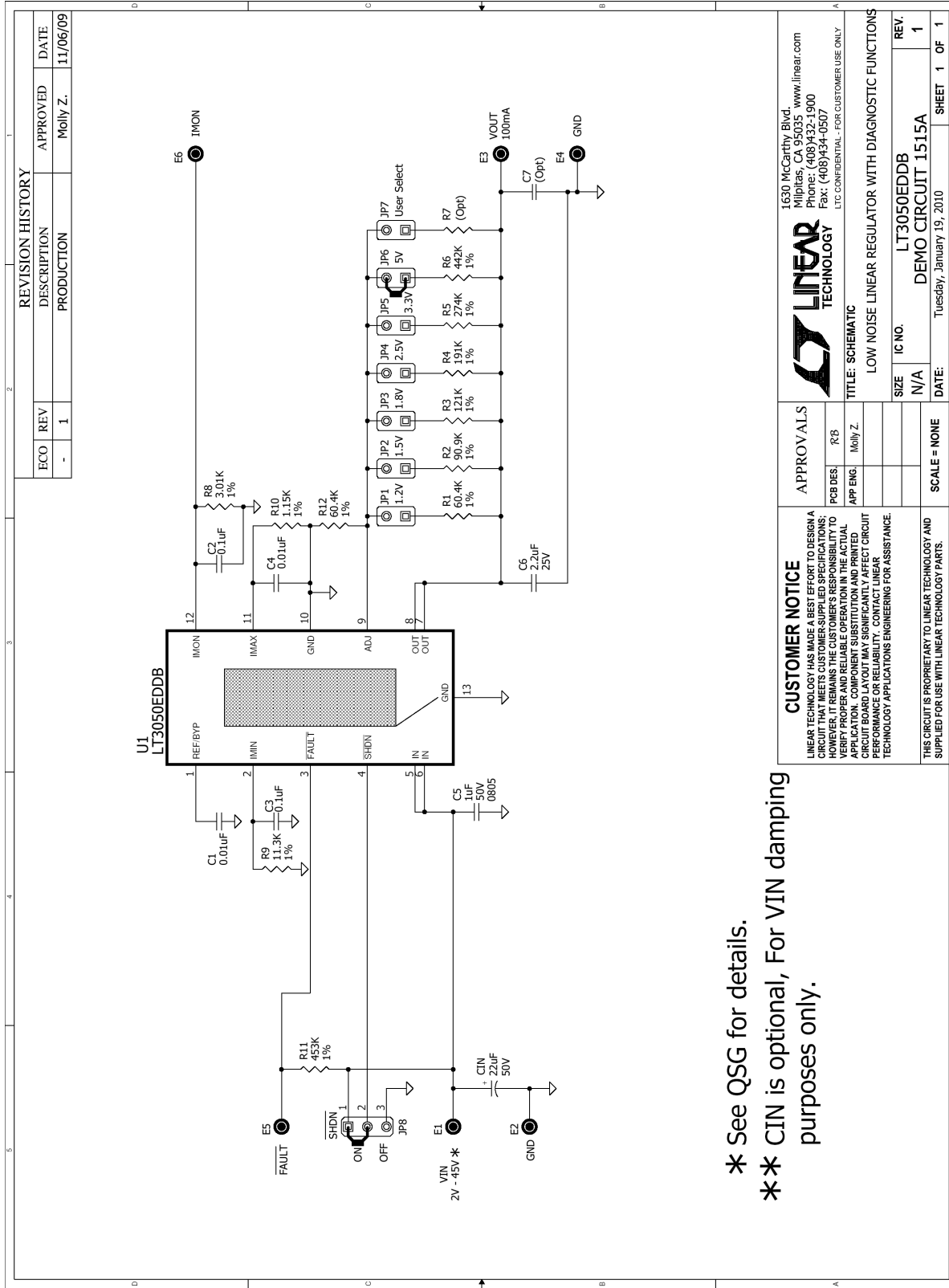



Figure 1. Proper Measurement Equipment Setup



REVISION HISTORY			
ECO	REV	DESCRIPTION	APPROVED
-	1	PRODUCTION	Molly Z.
			DATE
			11/06/09

		1630 McCarthy Blvd. Milpitas, CA 95035 - www.linear.com Phone: (408)432-1900 Fax: (408)434-0507 <small>LIC CONFIDENTIAL - FOR CUSTOMER USE ONLY</small>	
<b>CUSTOMER NOTICE</b> LINEAR TECHNOLOGY HAS MADE A BEST EFFORT TO DESIGN A CIRCUIT THAT MEETS CUSTOMER-SUPPLIED SPECIFICATIONS; HOWEVER, IT REMAINS THE CUSTOMER'S RESPONSIBILITY TO VERIFY PROPER AND RELIABLE OPERATION IN THE ACTUAL APPLICATION. COMPONENT SUBSTITUTION AND PRINTED CIRCUIT BOARD MANUFACTURING VARIATIONS MAY AFFECT CIRCUIT PERFORMANCE OR RELIABILITY. CONTACT LINEAR TECHNOLOGY APPLICATIONS ENGINEERING FOR ASSISTANCE.		<b>APPROVALS</b> PCB DES: R/B APP ENG: Molly Z.	
<b>TITLE: SCHEMATIC</b> LOW NOISE LINEAR REGULATOR WITH DIAGNOSTIC FUNCTIONS		SIZE: IC NO. LT3050EDDB N/A: DEMO CIRCUIT 1515A DATE: Tuesday, January 19, 2010 SCALE = NONE	
THIS CIRCUIT IS PROPRIETARY TO LINEAR TECHNOLOGY AND SUPPLIED FOR USE WITH LINEAR TECHNOLOGY PARTS.		REV. 1 SHEET 1 OF 1	

\* See QSG for details.  
 \*\* CIN is optional, For VIN damping purposes only.