

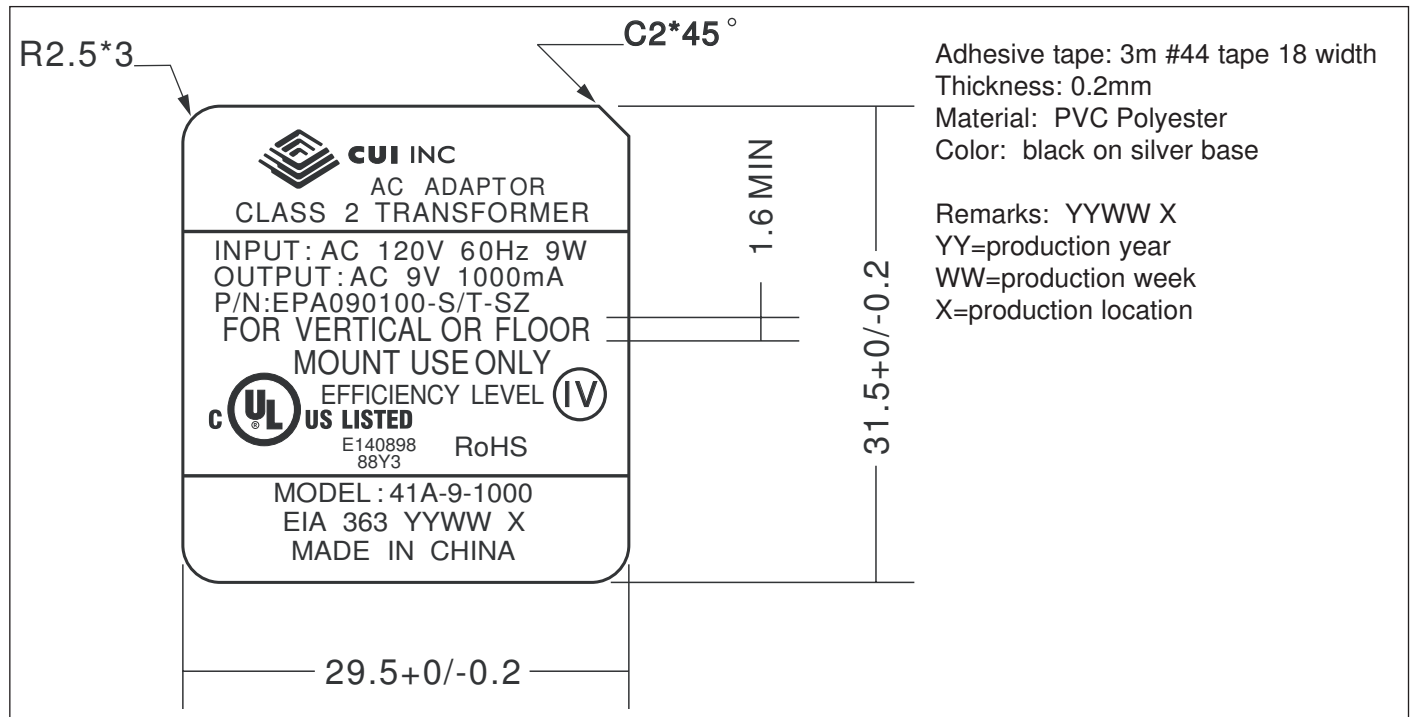

**Specifications**

Output voltage	9 V ac at 1000 mA	
Rated input voltage	120 V ac	
Primary rated voltage	120 V ac 60 Hz 9 W	
Primary exciting current	30 mA rms max.	
Secondary rated voltage & current	no load voltage (max.)	11.8 V ref
	full load voltage (1000 mA)	9 V $\pm$ 5%
Temperature rise of primary winding (full load)	70°C max. using resistance method	
Insulation resistance	$\geq$ 100 M Ohm at 500 V dc	
HI-POT test	from input to output for 1 min.	1240 V ac at 2 mA
	from input to output for 1 sec.	1600 V ac at 2 mA
	from primary to secondary winding for 1 sec.	1600 V ac at 2 mA
	from primary winding to core for 1 sec.	1600 V ac at 2 mA
	from secondary winding to core for 1 sec.	750 V ac at 2 mA
Safety standards	UL/cUL	
RoHS compliant	yes	
No load power consumption	0.5 W max.	
Efficiency	Energy Star Compliant - Efficiency Level IV	
Test conditions	Ambient temp	40°C $\pm$ 2°C
	Humidity	90-95% 96 hours at Full Load
	Rated voltage	8 hours at full load
Adapter color	Case	black
	Cord	black



**Label**





Mechanical Drawing

Tolerance:  $\pm 1$

Weight 330 g

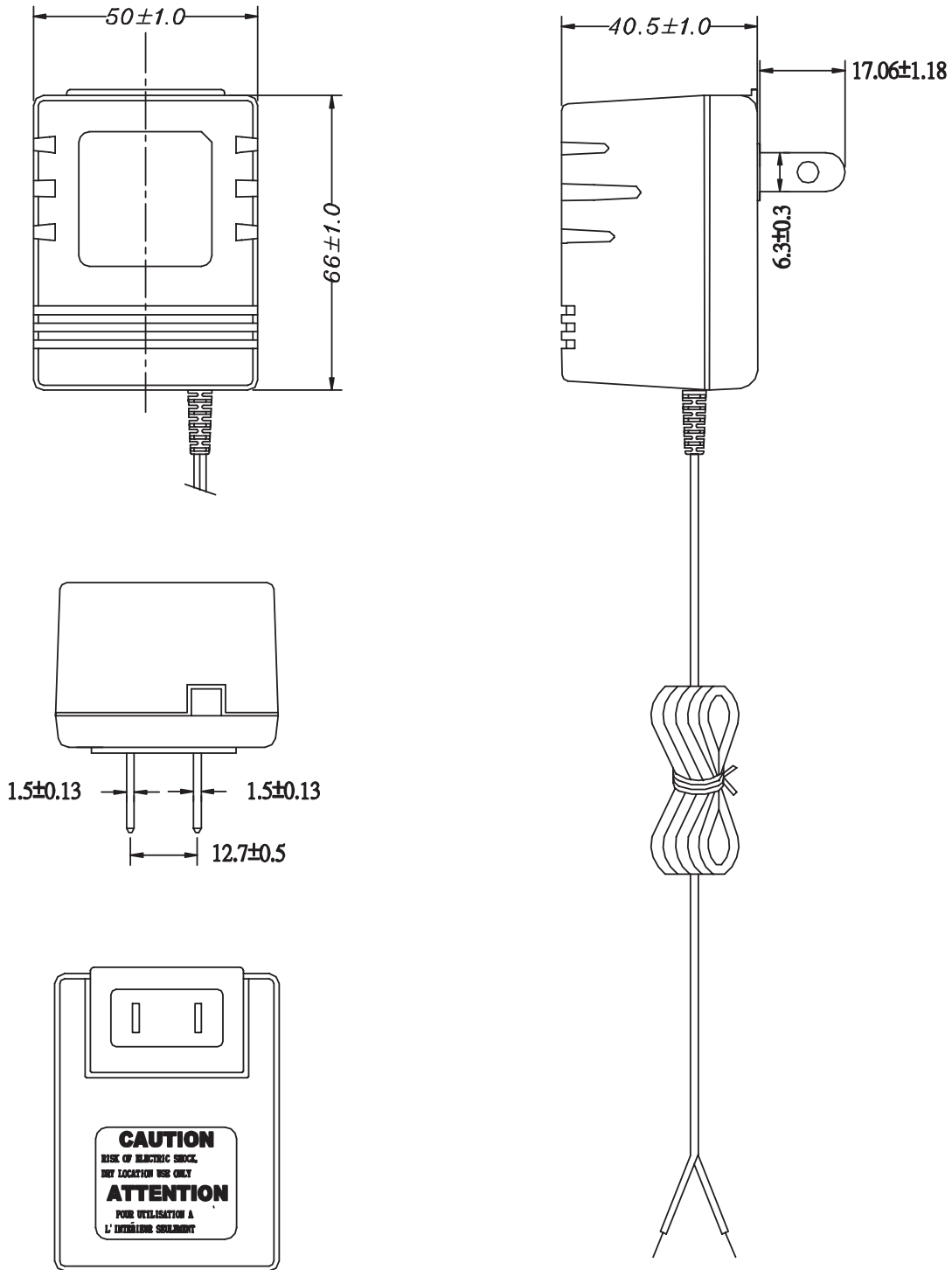



DC Cord

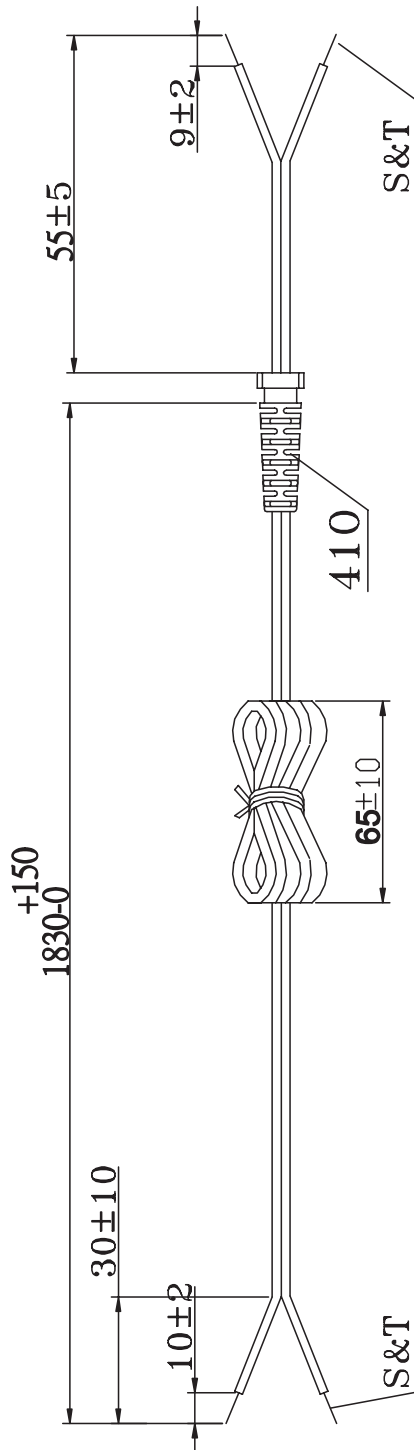

#22AWG X2C BLACK/WHITE WIRE BLACK WIRE IN NEGATIVE, BLACK/WHITE WIRE IN POSITIVE  
 WIRE OD:  $\varnothing 1.8 \times 3.6$

Parameter request	
VIBRATION TEST	a. $\pm 60^\circ$
	b. WEIGHT 200g
	c. 40 ROUND/MINUTE
	d. OVER 1000 COUNT MIN

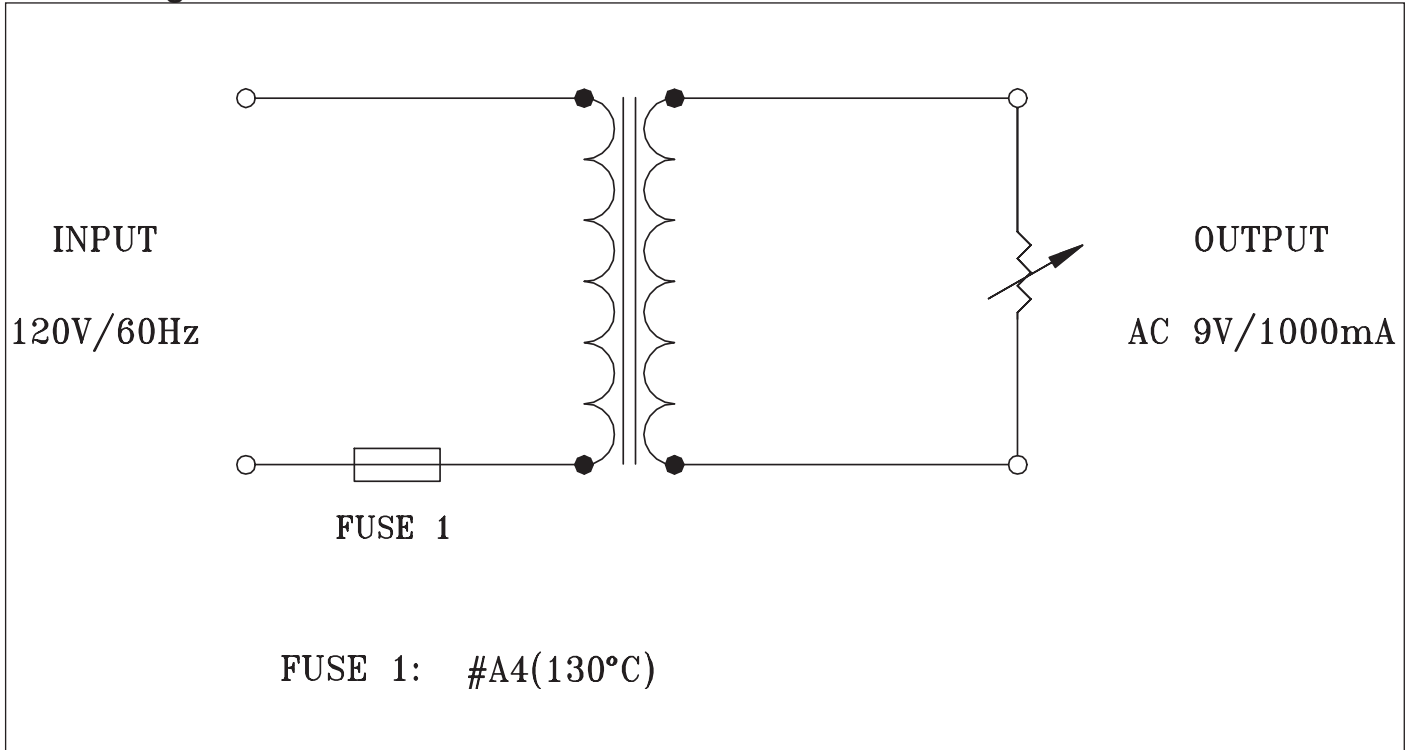
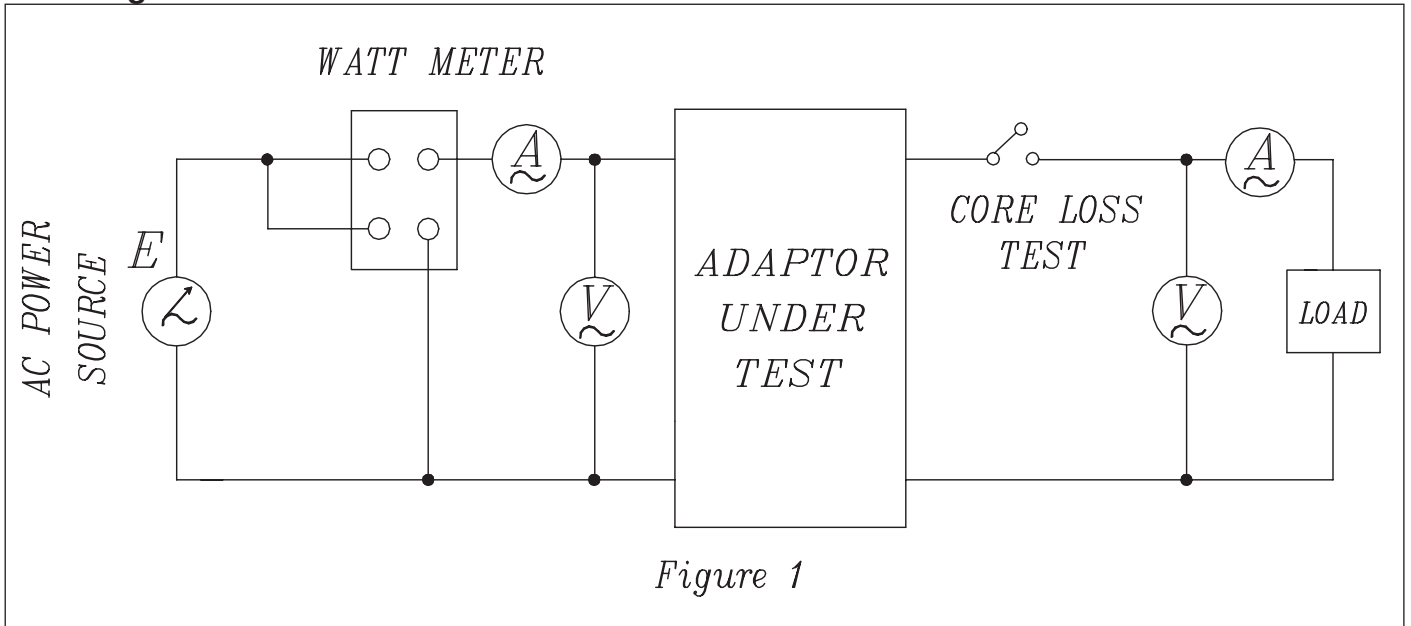
**Circuit Diagrams**

**Test Diagram**



**CUI INC**

Part No: EPA090100-S/T-SZ

Date: 5/11/2007

Unit: mm

Description: linear power supply

Page No: 6 of 7

### Individual Packaging

Tolerance:  $\pm 1$

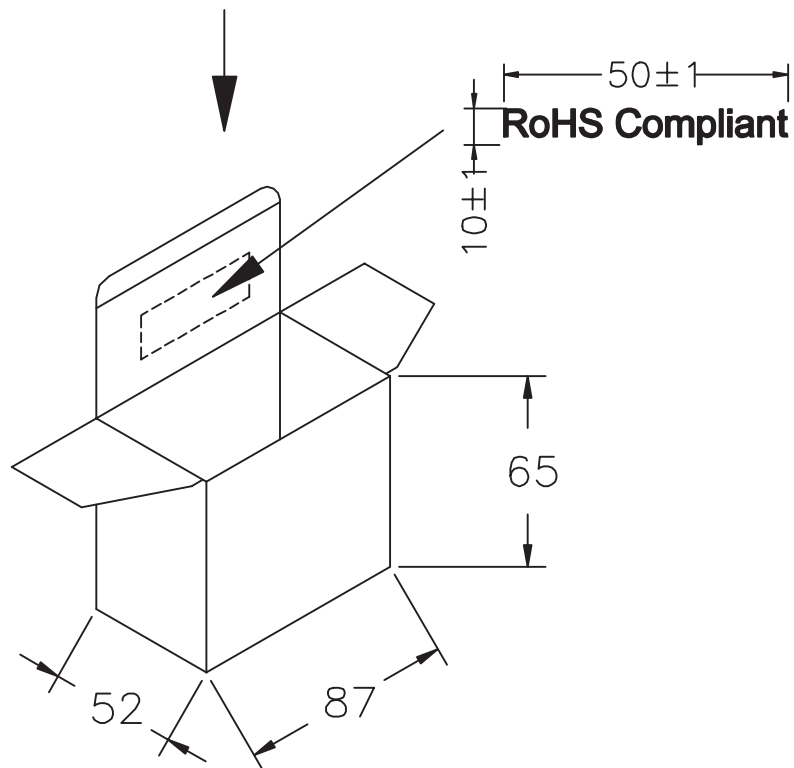
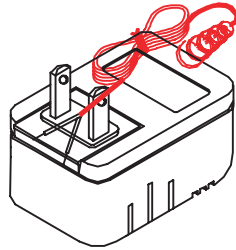

**Packaging**

Tolerance: +7/-0

EXTERNAL CARTON MATERIAL:A=B(6mm)

CARTON SIZE: 352X286X140mm

Q'TY: 30pcs(15\*2)

