

National Semiconductor is now part of
Texas Instruments.

Search <http://www.ti.com/> for the latest technical
information and details on our current products and services.



NATL SEMICON (LINEAR)

T-58-11-13

LM140A/LM140/LM340A/LM340/LM7800/LM7800C Series 3-Terminal Positive Regulators

General Description

The LM140A/LM140/LM340A/LM340/LM7800/LM7800C monolithic 3-terminal positive voltage regulators employ internal current-limiting, thermal shutdown and safe-area compensation, making them essentially indestructible. If adequate heat sinking is provided, they can deliver over 1.0A output current. They are interted as fixed voltage regulators in a wide range of applications including local (on-card) regulation for elimination of noise and distribution problems associated with single-point regulation. In addition to use as fixed voltage regulators, these devices can be used with external components to obtain adjustable output voltages and currents.

Considerable effort was expended to make the entire series of regulators easy to use and minimize the number of external components. It is not necessary to bypass the output, although this does improve transient response. Input bypassing is needed only if the regulator is located far from the filter capacitor of the power supply.

The entire series of regulators is available in the steel TO-3 power package. The LM340A/LM340/LM7800/LM7800C series is also available in the TO-220 plastic power package.

Features

- Complete specifications at 1A load
- Output voltage tolerances of $\pm 2\%$ at $T_j = 25^\circ\text{C}$ and $\pm 4\%$ over the temperature range (LM140A/LM340A)
- Line regulation of 0.01% of V_{OUT}/V of ΔV_{IN} at 1A load (LM140A/LM340A)
- Load regulation of 0.3% of V_{OUT}/A (LM140A/LM340A)
- Internal thermal overload protection
- Internal short-circuit current limit
- Output transistor safe area protection
- P+ Product Enhancement tested

Device	Output Voltages	Packages
LM140A/LM140	5, 12, 15	TO-3 (K)
LM340A/LM340	5, 12, 15	TO-3 (K), TO-220 (T)
LM7800	8, 18, 24	TO-3 (K), TO-220 (T)
LM7800C	5, 6, 8, 12, 15, 18, 24	TO-3 (K), TO-220 (T)

Typical Applications

Fixed Output Regulator

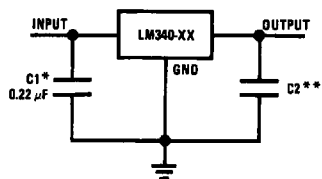

TL/H/7781-1

*Required if the regulator is located far from the power supply filter.

**Although no output capacitor is needed for stability, it does help transient response. (If needed, use 0.1 μF , ceramic disc).

Adjustable Output Regulator

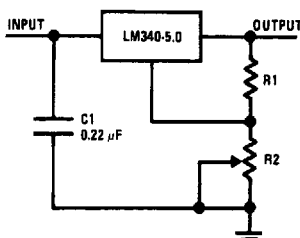

TL/H/7781-2

$V_{\text{OUT}} = 5V + (5V/R1 + I_Q) R2$ $5V/R1 > 3 I_Q$,
load regulation (L_r) $\approx [(R1 + R2)/R1]$ (L_r of LM340-5).

Current Regulator

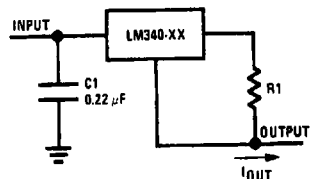

TL/H/7781-3

$$I_{\text{OUT}} = \frac{V_{2-3}}{R1} + I_Q$$

$\Delta I_Q = 1.3 \text{ mA}$ over line and load changes.

Absolute Maximum Ratings (Note 1)

If Military/Aerospace specified devices are required, please contact the National Semiconductor Sales Office/Distributors for availability and specifications. (Note 5)

DC Input Voltage	
All Devices except LM7824/LM7824C	35V
LM7824/LM7824C	40V
Internal Power Dissipation (Note 2)	Internally Limited
Maximum Junction Temperature	150°C
Storage Temperature Range	-65°C to +150°C
Lead Temperature (Soldering, 10 sec.)	
TO-3 Package (K, KC)	300°C
TO-220 Package (T)	230°C
ESD Susceptibility (Note 3)	2 kV

Operating Conditions (Note 1)

Temperature Range (T_A) (Note 2)	
LM140A, LM140, LM7808, LM7818, LM7824	-55°C to +125°C
LM340A, LM340, LM7805C, LM7812C, LM7815C	0°C to +70°C
LM7806C, LM7808C, LM7818C, LM7824C	0°C to +125°C

NATL SEMICOND (LINEAR)

LM140A/LM340A**Electrical Characteristics**

$I_{OUT} = 1A$, $-55^\circ C \leq T_J \leq +150^\circ C$ (LM140A), or $0^\circ C \leq T_J \leq +125^\circ C$ (LM340A) unless otherwise specified (Note 4)

Symbol	Output Voltage		5V			12V			15V			Units
	Input Voltage (unless otherwise noted)		10V			19V			23V			
	Parameter	Conditions	Min	Typ	Max	Min	Typ	Max	Min	Typ	Max	
V_O	Output Voltage	$T_J = 25^\circ C$	4.9	5	5.1	11.75	12	12.25	14.7	15	15.3	V
		$P_D \leq 15W$, $5 mA \leq I_O \leq 1A$	4.8		5.2	11.5		12.5	14.4		15.6	V
		$V_{MIN} \leq V_{IN} \leq V_{MAX}$	(7.5 $\leq V_{IN} \leq 20$)			(14.8 $\leq V_{IN} \leq 27$)			(17.9 $\leq V_{IN} \leq 30$)			V
ΔV_O	Line Regulation	$I_O = 500 mA$	10			18			22			mV
		ΔV_{IN}	(7.5 $\leq V_{IN} \leq 20$)			(14.8 $\leq V_{IN} \leq 27$)			(17.9 $\leq V_{IN} \leq 30$)			V
		$T_J = 25^\circ C$	3 10			4 18			4 22			mV
		ΔV_{IN}	(7.5 $\leq V_{IN} \leq 20$)			(14.5 $\leq V_{IN} \leq 27$)			(17.5 $\leq V_{IN} \leq 30$)			V
ΔV_O	Load Regulation	$T_J = 25^\circ C$	5 mA $\leq I_O \leq 1.5A$		10	25	12	32	12		35	mV
			250 mA $\leq I_O \leq 750 mA$				15	19			21	mV
		Over Temperature, 5 mA $\leq I_O \leq 1A$			25		60				75	mV
I_Q	Quiescent Current	$T_J = 25^\circ C$	6			6			6			mA
		Over Temperature	6.5			6.5			6.5			mA
ΔI_Q	Quiescent Current Change	$5 mA \leq I_O \leq 1A$	0.5			0.5			0.5			mA
		$T_J = 25^\circ C$, $I_O = 1A$	0.8			0.8			0.8			mA
		$V_{MIN} \leq V_{IN} \leq V_{MAX}$	(7.5 $\leq V_{IN} \leq 20$)			(14.8 $\leq V_{IN} \leq 27$)			(17.9 $\leq V_{IN} \leq 30$)			V
V_N	Output Noise Voltage	$T_A = 25^\circ C$, 10 Hz $\leq f \leq 100$ kHz	40			75			90			μV
		ΔV_{IN}										
ΔV_{OUT}	Ripple Rejection	$T_J = 25^\circ C$, $f = 120$ Hz, $I_O = 1A$	68	80		61	72		60	70		dB
		or $f = 120$ Hz, $I_O = 500$ mA, Over Temperature,	68			61			60			dB
		$V_{MIN} \leq V_{IN} \leq V_{MAX}$	(8 $\leq V_{IN} \leq 18$)			(15 $\leq V_{IN} \leq 25$)			(18.5 $\leq V_{IN} \leq 28.5$)			V
R_O	Dropout Voltage	$T_J = 25^\circ C$, $I_O = 1A$	2.0			2.0			2.0			V
	Output Resistance	$f = 1$ kHz	8			18			19			m Ω
	Short-Circuit Current	$T_J = 25^\circ C$	2.1			1.5			1.2			A
	Peak Output Current	$T_J = 25^\circ C$	2.4			2.4			2.4			A
	Average TC of V_O	Min, $T_J = 0^\circ C$, $I_O = 5 mA$	-0.6			-1.5			-1.8			mV/ $^\circ C$
V_{IN}	Input Voltage Required to Maintain Line Regulation	$T_J = 25^\circ C$	7.5			14.5			17.5			V

LM140

NATL SEMICOND (LINEAR)

Electrical Characteristics (Note 4) $-55^{\circ}\text{C} \leq T_J \leq +150^{\circ}\text{C}$ unless otherwise specified

Symbol	Output Voltage		5V			12V			15V			Units	
	Input Voltage (unless otherwise noted)		10V			19V			23V				
	Parameter	Conditions	Min	Typ	Max	Min	Typ	Max	Min	Typ	Max		
V_O	Output Voltage	$T_J = 25^{\circ}\text{C}, 5\text{ mA} \leq I_O \leq 1\text{ A}$	4.8	5	5.2	11.5	12	12.5	14.4	15	15.6	V	
		$P_D \leq 15\text{ W}, 5\text{ mA} \leq I_O \leq 1\text{ A}$	4.75		5.25	11.4		12.6	14.25		15.75	V	
		$V_{\text{MIN}} \leq V_{\text{IN}} \leq V_{\text{MAX}}$			($8 \leq V_{\text{IN}} \leq 20$)			($15.5 \leq V_{\text{IN}} \leq 27$)			($18.5 \leq V_{\text{IN}} \leq 30$)	V	
ΔV_O	Line Regulation	$I_O = 500\text{ mA}$	$T_J = 25^{\circ}\text{C}$		3	50		4	120		4	150	mV
			ΔV_{IN}		($7 \leq V_{\text{IN}} \leq 25$)		($14.5 \leq V_{\text{IN}} \leq 30$)		($17.5 \leq V_{\text{IN}} \leq 30$)			V	
			$-55^{\circ}\text{C} \leq T_J \leq +150^{\circ}\text{C}$			50		120		150			mV
		$I_O \leq 1\text{ A}$	ΔV_{IN}		($8 \leq V_{\text{IN}} \leq 20$)		($15 \leq V_{\text{IN}} \leq 27$)		($18.5 \leq V_{\text{IN}} \leq 30$)			V	
			$T_J = 25^{\circ}\text{C}$			50		120		150			mV
			ΔV_{IN}		($7.5 \leq V_{\text{IN}} \leq 20$)		($14.6 \leq V_{\text{IN}} \leq 27$)		($17.7 \leq V_{\text{IN}} \leq 30$)			V	
ΔV_O	Load Regulation	$T_J = 25^{\circ}\text{C}$	$5\text{ mA} \leq I_O \leq 1.5\text{ A}$		10	50		12	120		12	150	mV
			$250\text{ mA} \leq I_P \leq 750\text{ mA}$			25		60		75			mV
			$-55^{\circ}\text{C} \leq T_J \leq +150^{\circ}\text{C}, 5\text{ mA} \leq I_O \leq 1\text{ A}$			50		120		150			mV
		$I_O \leq 1\text{ A}$	$T_J = 25^{\circ}\text{C}$			6		6		6		6	mA
			$-55^{\circ}\text{C} \leq T_J \leq +150^{\circ}\text{C}$			7		7		7		7	mA
						0.5		0.5		0.5		0.5	mA
ΔI_Q	Quiescent Current Change	$5\text{ mA} \leq I_O \leq 1\text{ A}$			0.5		0.5		0.5		0.5	mA	
		$T_J = 25^{\circ}\text{C}, I_O \leq 1\text{ A}$			0.8		0.8		0.8		0.8	mA	
		$V_{\text{MIN}} \leq V_{\text{IN}} \leq V_{\text{MAX}}$		($8 \leq V_{\text{IN}} \leq 20$)		($15 \leq V_{\text{IN}} \leq 27$)		($18.5 \leq V_{\text{IN}} \leq 30$)			V		
		$I_O = 500\text{ mA}, -55^{\circ}\text{C} \leq T_J \leq +150^{\circ}\text{C}$			0.8		0.8		0.8		0.8	mA	
V_N	Output Noise Voltage	$T_A = 25^{\circ}\text{C}, 10\text{ Hz} \leq f \leq 100\text{ kHz}$			40		75		90			μV	
		$\frac{\Delta V_{\text{IN}}}{\Delta V_{\text{OUT}}}$	Ripple Rejection	$f = 120\text{ Hz}$	$I_O \leq 1\text{ A}, T_J = 25^{\circ}\text{C}$ or	68	80	61	72	60	70		dB
					$I_O \leq 500\text{ mA}, -55^{\circ}\text{C} \leq T_J \leq +150^{\circ}\text{C}$	68		61		60			
		$V_{\text{MIN}} \leq V_{\text{IN}} \leq V_{\text{MAX}}$		($8 \leq V_{\text{IN}} \leq 18$)		($15 \leq V_{\text{IN}} \leq 25$)		($18.5 \leq V_{\text{IN}} \leq 28.5$)			V		
R_O	Dropout Voltage Output Resistance Short-Circuit Current Peak Output Current Average TC of V_{OUT}	$T_J = 25^{\circ}\text{C}, I_O = 1\text{ A}$			2.0		2.0		2.0			V	
		$f = 1\text{ kHz}$			8		18		19			$\text{m}\Omega$	
		$T_J = 25^{\circ}\text{C}$			2.1		1.5		1.2			A	
		$T_J = 25^{\circ}\text{C}$			2.4		2.4		2.4			A	
		$0^{\circ}\text{C} \leq T_J \leq +150^{\circ}\text{C}, I_O = 5\text{ mA}$			-0.6		-1.5		-1.8			$\text{mV}/^{\circ}\text{C}$	
V_{IN}	Input Voltage Required to Maintain Line Regulation	$T_J = 25^{\circ}\text{C}, I_O \leq 1\text{ A}$			7.5		14.6		17.7			V	

LM340/LM7800C

NATL SEMICOND (LINEAR)

Electrical Characteristics (Note 4) $0^{\circ}\text{C} \leq T_J \leq +125^{\circ}\text{C}$ unless otherwise specified

Symbol	Output Voltage		5V			12V			15V			Units	
	Input Voltage (unless otherwise noted)		10V			19V			23V				
	Parameter	Conditions	Min	Typ	Max	Min	Typ	Max	Min	Typ	Max		
V_O	Output Voltage	$T_J = 25^{\circ}\text{C}, 5\text{ mA} \leq I_O \leq 1\text{ A}$	4.8	5	5.2	11.5	12	12.5	14.4	15	15.6	V	
		$P_D \leq 15\text{ W}, 5\text{ mA} \leq I_O \leq 1\text{ A}$	4.75		5.25	11.4		12.6	14.25		15.75	V	
		$V_{\text{MIN}} \leq V_{\text{IN}} \leq V_{\text{MAX}}$	(7.5 $\leq V_{\text{IN}} \leq 20$)				(14.5 $\leq V_{\text{IN}} \leq 27$)			(17.5 $\leq V_{\text{IN}} \leq 30$)		V	
ΔV_O	Line Regulation	$I_O = 500\text{ mA}$	$T_J = 25^{\circ}\text{C}$	3	50		4	120		4	150	mV	
			ΔV_{IN}	(7 $\leq V_{\text{IN}} \leq 25$)			(14.5 $\leq V_{\text{IN}} \leq 30$)			(17.5 $\leq V_{\text{IN}} \leq 30$)		V	
			$0^{\circ}\text{C} \leq T_J \leq +125^{\circ}\text{C}$			50			120			150	mV
		$I_O \leq 1\text{ A}$	ΔV_{IN}	(8 $\leq V_{\text{IN}} \leq 20$)				(15 $\leq V_{\text{IN}} \leq 27$)			(18.5 $\leq V_{\text{IN}} \leq 30$)		V
			$T_J = 25^{\circ}\text{C}$			50			120			150	mV
			ΔV_{IN}	(7.5 $\leq V_{\text{IN}} \leq 20$)				(14.6 $\leq V_{\text{IN}} \leq 27$)			(17.7 $\leq V_{\text{IN}} \leq 30$)		V
ΔV_O	Load Regulation	$T_J = 25^{\circ}\text{C}$	$5\text{ mA} \leq I_O \leq 1.5\text{ A}$		10	50		12	120		12	150	mV
			$250\text{ mA} \leq I_O \leq 750\text{ mA}$			25			60			75	mV
		$5\text{ mA} \leq I_O \leq 1\text{ A}, 0^{\circ}\text{C} \leq T_J \leq +125^{\circ}\text{C}$			50			120			150	mV	
I_Q	Quiescent Current	$I_O \leq 1\text{ A}$	$T_J = 25^{\circ}\text{C}$			8			8			8	mA
			$0^{\circ}\text{C} \leq T_J \leq +125^{\circ}\text{C}$			8.5			8.5			8.5	mA
						0.5			0.5			0.5	mA
ΔI_Q	Quiescent Current Change	$5\text{ mA} \leq I_O \leq 1\text{ A}$	$T_J = 25^{\circ}\text{C}, I_O \leq 1\text{ A}$			1.0			1.0			1.0	mA
			$V_{\text{MIN}} \leq V_{\text{IN}} \leq V_{\text{MAX}}$	(7.5 $\leq V_{\text{IN}} \leq 20$)				(14.8 $\leq V_{\text{IN}} \leq 27$)			(17.9 $\leq V_{\text{IN}} \leq 30$)		V
			$I_O \leq 500\text{ mA}, 0^{\circ}\text{C} \leq T_J \leq +125^{\circ}\text{C}$			1.0			1.0			1.0	mA
			$V_{\text{MIN}} \leq V_{\text{IN}} \leq V_{\text{MAX}}$	(7 $\leq V_{\text{IN}} \leq 25$)				(14.5 $\leq V_{\text{IN}} \leq 30$)			(17.5 $\leq V_{\text{IN}} \leq 30$)		V
V_N	Output Noise Voltage	$T_A = 25^{\circ}\text{C}, 10\text{ Hz} \leq f \leq 100\text{ kHz}$		40			75			90	μV		
$\frac{\Delta V_{\text{IN}}}{\Delta V_{\text{OUT}}}$	Ripple Rejection	$f = 120\text{ Hz}$	$I_O \leq 1\text{ A}, T_J = 25^{\circ}\text{C}$	62	80		55	72		54	70	dB	
			or $I_O \leq 500\text{ mA},$	62			55			54		dB	
			$0^{\circ}\text{C} \leq T_J \leq +125^{\circ}\text{C}$										V
		$V_{\text{MIN}} \leq V_{\text{IN}} \leq V_{\text{MAX}}$	(8 $\leq V_{\text{IN}} \leq 18$)			(15 $\leq V_{\text{IN}} \leq 25$)			(18.5 $\leq V_{\text{IN}} \leq 28.5$)		V		
R_O	Dropout Voltage	$T_J = 25^{\circ}\text{C}, I_O = 1\text{ A}$		2.0			2.0			2.0	V		
	Output Resistance	$f = 1\text{ kHz}$		8			18			19	m Ω		
	Short-Circuit Current	$T_J = 25^{\circ}\text{C}$		2.1			1.5			1.2	A		
	Peak Output Current	$T_J = 25^{\circ}\text{C}$		2.4			2.4			2.4	A		
	Average TC of V_{OUT}	$0^{\circ}\text{C} \leq T_J \leq +125^{\circ}\text{C}, I_O = 5\text{ mA}$		-0.6			-1.5			-1.8	mV/ $^{\circ}\text{C}$		
V_{IN}	Input Voltage Required to Maintain Line Regulation	$T_J = 25^{\circ}\text{C}, I_O \leq 1\text{ A}$		7.5			14.6			17.7	V		

Note 1: Absolute Maximum Ratings are limits beyond which damage to the device may occur. Operating Conditions are conditions under which the device functions but the specifications might not be guaranteed. For guaranteed specifications and test conditions see the Electrical Characteristics.

Note 2: The maximum allowable power dissipation at any ambient temperature is a function of the maximum junction temperature for operation ($T_{\text{JMAX}} = 125^{\circ}\text{C}$ or 150°C), the junction-to-ambient thermal resistance (θ_{JA}), and the ambient temperature (T_A). $P_{\text{DMAX}} = (T_{\text{JMAX}} - T_A)/\theta_{\text{JA}}$. If this dissipation is exceeded, the die temperature will rise above T_{JMAX} and the electrical specifications do not apply. If the die temperature rises above 150°C , the device will go into thermal shutdown. For the TO-3 package (K, KC), the junction-to-ambient thermal resistance (θ_{JA}) is $39^{\circ}\text{C}/\text{W}$. When using a heatsink, θ_{JA} is the sum of the $4^{\circ}\text{C}/\text{W}$ junction-to-case thermal resistance (θ_{JC}) of the TO-3 package and the case-to-ambient thermal resistance of the heatsink. For the TO-220 package (T), θ_{JA} is $54^{\circ}\text{C}/\text{W}$ and θ_{JC} is $4^{\circ}\text{C}/\text{W}$.

Note 3: ESD rating is based on the human body model, 100 pF discharged through 1.5 k Ω .

Note 4: All characteristics are measured with a 0.22 μF capacitor from input to ground and a 0.1 μF capacitor from output to ground. All characteristics except noise voltage and ripple rejection ratio are measured using pulse techniques ($t_w \leq 10\text{ ms}$, duty cycle $\leq 5\%$). Output voltage changes due to changes in internal temperature must be taken into account separately.

Note 5: A military RETS specification is available on request. At the time of printing, the military RETS specifications for the LM140AK-5.0/883, LM140AK-12/883, and LM140AK-15/883 complied with the min and max limits for the respective versions of the LM140A. At the time of printing, the military RETS specifications for the LM140K-5.0/883, LM140K-12/883, and LM140K-15/883 complied with the min and max limits for the respective versions of the LM140. The LM140H/883, LM140K/883, and LM140AK/883 may also be procured as a Standard Military Drawing.

LM7806C**NATL SEMICONDUCTOR (LINEAR)****Electrical Characteristics**
 $0^{\circ}\text{C} \leq T_J \leq +150^{\circ}\text{C}$, $V_I = 11\text{V}$, $I_O = 500\text{ mA}$, $C_I = 0.33\ \mu\text{F}$, $C_O = 0.1\ \mu\text{F}$, unless otherwise specified

Symbol	Parameter	Conditions (Note 4)	Min	Typ	Max	Units
V_O	Output Voltage	$T_J = 25^{\circ}\text{C}$	5.75	6.0	6.25	V
ΔV_O	Line Regulation	$T_J = 25^{\circ}\text{C}$		5.0	120	mV
		$8.0\text{V} \leq V_I \leq 25\text{V}$				
		$9.0\text{V} \leq V_I \leq 13\text{V}$		1.5	60	
ΔV_O	Load Regulation	$T_J = 25^{\circ}\text{C}$		14	120	mV
		$5.0\text{ mA} \leq I_O \leq 1.5\text{ A}$				
		$250\text{ mA} \leq I_O \leq 750\text{ mA}$		4.0	60	
V_O	Output Voltage	$8.0\text{V} \leq V_I \leq 21\text{V}$, $5.0\text{ mA} \leq I_O \leq 1.0\text{ A}$, $P \leq 15\text{W}$	5.7		6.3	V
I_Q	Quiescent Current	$T_J = 25^{\circ}\text{C}$		4.3	8.0	mA
ΔI_Q	Quiescent Current Change	With Line			1.3	mA
		With Load	$8.0\text{V} \leq V_I \leq 25\text{V}$			
		$5.0\text{ mA} \leq I_O \leq 1.0\text{ A}$			0.5	
V_N	Noise	$T_A = 25^{\circ}\text{C}$, $10\text{ Hz} \leq f \leq 100\text{ kHz}$		45		μV
$\Delta V_I/\Delta V_O$	Ripple Rejection	$f = 120\text{ Hz}$, $I_O = 350\text{ mA}$, $T_J = 25^{\circ}\text{C}$	59	75		dB
V_{DO}	Dropout Voltage	$I_O = 1.0\text{ A}$, $T_J = 25^{\circ}\text{C}$		2.0		V
R_O	Output Resistance	$f = 1.0\text{ kHz}$		9		$\text{m}\Omega$
I_{OS}	Output Short Circuit Current	$T_J = 25^{\circ}\text{C}$, $V_I = 35\text{V}$		550		mA
I_{PK}	Peak Output Current	$T_J = 25^{\circ}\text{C}$		2.2		A
$\Delta V_O/\Delta T$	Average Temperature Coefficient of Output Voltage	$I_O = 5.0\text{ mA}$, $0^{\circ}\text{C} \leq T_A \leq +125^{\circ}\text{C}$		0.8		$\text{mV}/^{\circ}\text{C}$

LM7808/LM7808C**Electrical Characteristics**
 $-55^{\circ}\text{C} \leq T_J \leq +150^{\circ}\text{C}$ (LM7808) or $0^{\circ}\text{C} \leq T_J \leq +150^{\circ}\text{C}$ (LM7808C), $V_I = 14\text{V}$, $I_O = 500\text{ mA}$, $C_I = 0.33\ \mu\text{F}$, $C_O = 0.1\ \mu\text{F}$, unless otherwise specified

Symbol	Parameter	Conditions (Note 4)	LM7808			LM7808C			Units
			Min	Typ	Max	Min	Typ	Max	
V_O	Output Voltage	$T_J = 25^{\circ}\text{C}$	7.7	8.0	8.3	7.7	8.0	8.3	V
ΔV_O	Line Regulation	$T_J = 25^{\circ}\text{C}$							mV
		$10.5\text{V} \leq V_I \leq 25\text{V}$		6.0	80		6.0	160	
		$11.0\text{V} \leq V_I \leq 17\text{V}$		2.0	40		2.0	80	
ΔV_O	Load Regulation	$T_J = 25^{\circ}\text{C}$							mV
		$5.0\text{ mA} \leq I_O \leq 1.5\text{ A}$		12	100		12	160	
		$250\text{ mA} \leq I_O \leq 750\text{ mA}$		4.0	40		4.0	80	
V_O	Output Voltage	$11.5\text{V} \leq V_I \leq 23\text{V}$, $5.0\text{ mA} \leq I_O \leq 1.0\text{ A}$, $P \leq 15\text{W}$	7.6		8.4	7.6		8.4	V
I_Q	Quiescent Current	$T_J = 25^{\circ}\text{C}$		4.3	6.0		4.3	8.0	mA
ΔI_Q	Quiescent Current Change	With Line			0.8			1.0	mA
		With Load	$11.5\text{V} \leq V_I \leq 25\text{V}$						
		$5.0\text{ mA} \leq I_O \leq 1.0\text{ A}$			0.5			0.5	
V_N	Noise	$T_A = 25^{\circ}\text{C}$, $10\text{ Hz} \leq f \leq 100\text{ kHz}$		64	320		52		μV
$\Delta V_I/\Delta V_O$	Ripple Rejection	$f = 120\text{ Hz}$, $I_O = 350\text{ mA}$, $T_J = 25^{\circ}\text{C}$	62	72		56	72		dB
V_{DO}	Dropout Voltage	$I_O = 1.0\text{ A}$, $T_J = 25^{\circ}\text{C}$		2.0	2.5		2.0		V
R_O	Output Resistance	$f = 1.0\text{ kHz}$		16			16		$\text{m}\Omega$
I_{OS}	Output Short Circuit Current	$T_J = 25^{\circ}\text{C}$, $V_I = 35\text{V}$		0.75	1.2		0.45		A
I_{PK}	Peak Output Current	$T_J = 25^{\circ}\text{C}$		1.3	2.2		2.2		A
$\Delta V_O/\Delta T$	Average Temperature Coefficient of Output Voltage	$I_O = 5.0\text{ mA}$	LM7808			0.4			$\text{mV}/^{\circ}\text{C}/V_O$
			LM7808				0.3		
			LM7808C					0.8	

Note 4: All characteristics are measured with a $0.22\ \mu\text{F}$ capacitor from input to ground and a $0.1\ \mu\text{F}$ capacitor from output to ground. All characteristics except noise voltage and ripple rejection ratio are measured using pulse techniques ($t_w \leq 10\text{ ms}$, duty cycle $\leq 5\%$). Output voltage changes due to changes in internal temperature must be taken into account separately.

LM7818/LM7818C

NATL SEMICON (LINEAR)

Electrical Characteristics $-55^{\circ}\text{C} \leq T_J \leq +150^{\circ}\text{C}$ (LM7818) or $0^{\circ}\text{C} \leq T_J \leq +150^{\circ}\text{C}$ (LM7818C), $V_I = 27\text{V}$,
 $I_O = 500\text{ mA}$, $C_I = 0.33\ \mu\text{F}$, $C_O = 0.1\ \mu\text{F}$, unless otherwise specified

Symbol	Parameter	Conditions (Note 4)	LM7818			LM7818C			Units	
			Min	Typ	Max	Min	Typ	Max		
V_O	Output Voltage	$T_J = 25^{\circ}\text{C}$	17.3	18.0	18.7	17.3	18.0	18.7	V	
ΔV_O	Line Regulation	$T_J = 25^{\circ}\text{C}$	$21\text{V} \leq V_I \leq 33\text{V}$			15	180	15	360	mV
			$24\text{V} \leq V_I \leq 30\text{V}$			5.0	90	5.0	180	
ΔV_O	Load Regulation	$T_J = 25^{\circ}\text{C}$	$5.0\text{ mA} \leq I_O \leq 1.5\text{ A}$			12	180	12	360	mV
			$250\text{ mA} \leq I_O \leq 750\text{ mA}$			4.0	90	4.0	180	
V_O	Output Voltage	$22\text{V} \leq V_I \leq 33\text{V}$, $5.0\text{ mA} \leq I_O \leq 1.0\text{ A}$, $P \leq 15\text{ W}$	17.1		18.9	17.1		18.9	V	
I_Q	Quiescent Current	$T_J = 25^{\circ}\text{C}$		4.5	6.0		4.5	8.0	mA	
ΔI_Q	Quiescent Current Change	With Line	$22\text{V} \leq V_I \leq 33\text{V}$				0.8		1.0	mA
		With Load	$5.0\text{ mA} \leq I_O \leq 1.0\text{ A}$				0.5		0.5	
V_N	Noise	$T_A = 25^{\circ}\text{C}$, $10\text{ Hz} \leq f \leq 100\text{ kHz}$		144	720		110		μV	
$\Delta V_I/\Delta V_O$	Ripple Rejection	$f = 120\text{ Hz}$, $I_O = 350\text{ mA}$, $T_J = 25^{\circ}\text{C}$	59	69		53	69		dB	
V_{DO}	Dropout Voltage	$I_O = 1.0\text{ A}$, $T_J = 25^{\circ}\text{C}$		2.0			2.0		V	
R_O	Output Resistance	$f = 1.0\text{ kHz}$		22			22		$\text{m}\Omega$	
I_{OS}	Output Short Circuit Current	$T_J = 25^{\circ}\text{C}$, $V_I = 35\text{V}$		0.75			0.20		A	
I_{PK}	Peak Output Current	$T_J = 25^{\circ}\text{C}$	1.3	2.2	3.3		2.1		A	
$\Delta V_O/\Delta T$	Average Temperature Coefficient of Output Voltage	$I_O = 5.0\text{ mA}$	LM7818	$-55^{\circ}\text{C} \leq T_A \leq +25^{\circ}\text{C}$				0.4		mV/ $^{\circ}\text{C}/V_O$
			LM7818	$+25^{\circ}\text{C} \leq T_A \leq +125^{\circ}\text{C}$				0.3		
			LM7818C						1.0	mV/ $^{\circ}\text{C}$

LM7824/LM7824C

Electrical Characteristics $-55^{\circ}\text{C} \leq T_J \leq +150^{\circ}\text{C}$ (LM7824) or $0^{\circ}\text{C} \leq T_J \leq +150^{\circ}\text{C}$ (LM7824C), $V_I = 33\text{V}$,
 $I_O = 500\text{ mA}$, $C_I = 0.33\ \mu\text{F}$, $C_O = 0.1\ \mu\text{F}$, unless otherwise specified

Symbol	Parameter	Conditions (Note 4)	LM7824			LM7824C			Units	
			Min	Typ	Max	Min	Typ	Max		
V_O	Output Voltage	$T_J = 25^{\circ}\text{C}$	23.0	24.0	25.0	23.0	24.0	25.0	V	
ΔV_O	Line Regulation	$T_J = 25^{\circ}\text{C}$	$27\text{V} \leq V_I \leq 38\text{V}$			18	240	18	480	mV
			$30\text{V} \leq V_I \leq 36\text{V}$			6.0	120	6.0	240	
ΔV_O	Load Regulation	$T_J = 25^{\circ}\text{C}$	$5.0\text{ mA} \leq I_O \leq 1.5\text{ A}$			12	240	12	480	mV
			$250\text{ mA} \leq I_O \leq 750\text{ mA}$			4.0	120	4.0	240	
V_O	Output Voltage	$28\text{V} \leq V_I \leq 38\text{V}$, $5.0\text{ mA} \leq I_O \leq 1.0\text{ A}$, $P \leq 15\text{ W}$	22.8		25.2	22.8		25.2	V	
I_Q	Quiescent Current	$T_J = 25^{\circ}\text{C}$		4.6	6.0		4.6	8.0	mA	
ΔI_Q	Quiescent Current Change	With Line	$28\text{V} \leq V_I \leq 38\text{V}$				0.8		1.0	mA
		With Load	$5.0\text{ mA} \leq I_O \leq 1.0\text{ A}$				0.5		0.5	
V_N	Noise	$T_A = 25^{\circ}\text{C}$, $10\text{ Hz} \leq f \leq 100\text{ kHz}$		192	960		170		μV	
$\Delta V_I/\Delta V_O$	Ripple Rejection	$f = 120\text{ Hz}$, $I_O = 350\text{ mA}$, $T_J = 25^{\circ}\text{C}$	56	66		50	66		dB	
V_{DO}	Dropout Voltage	$I_O = 1.0\text{ A}$, $T_J = 25^{\circ}\text{C}$		2.0	2.5		2.0		V	
R_O	Output Resistance	$f = 1.0\text{ kHz}$		28			28		$\text{m}\Omega$	
I_{OS}	Output Short Circuit Current	$T_J = 25^{\circ}\text{C}$, $V_I = 35\text{V}$		0.75	1.2		0.15		A	
I_{PK}	Peak Output Current	$T_J = 25^{\circ}\text{C}$	1.3	2.2	3.3		2.1		A	
$\Delta V_O/\Delta T$	Average Temperature Coefficient of Output Voltage	$I_O = 5.0\text{ mA}$	LM7824	$-55^{\circ}\text{C} \leq T_A \leq +25^{\circ}\text{C}$				0.4		mV/ $^{\circ}\text{C}/V_O$
			LM7824	$+25^{\circ}\text{C} \leq T_A \leq +125^{\circ}\text{C}$				0.3		
			LM7824C						1.5	mV/ $^{\circ}\text{C}$

Note 4: All characteristics are measured with a $0.22\ \mu\text{F}$ capacitor from input to ground and a $0.1\ \mu\text{F}$ capacitor from output to ground. All characteristics except noise voltage and ripple rejection ratio are measured using pulse techniques ($t_w \leq 10\text{ ms}$, duty cycle $\leq 5\%$). Output voltage changes due to changes in internal temperature must be taken into account separately.

Typical Performance Characteristics

LM140A/LM140/LM340A/LM340/LM7800/LM7800C

1

Maximum Average Power Dissipation

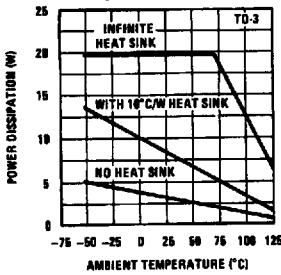

Maximum Average Power Dissipation

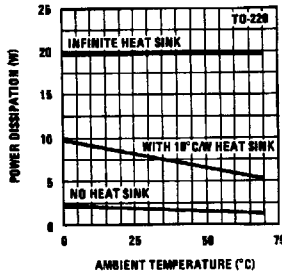

Peak Output Current

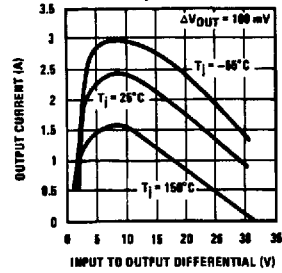

Output Voltage (Normalized to 1V at $T_j = 25^\circ\text{C}$)

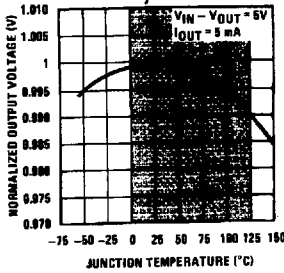

Ripple Rejection

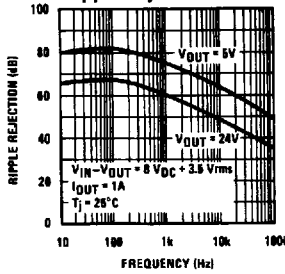

Ripple Rejection

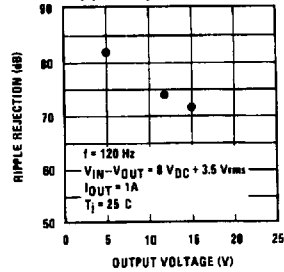

Note: Shaded area refers to LM340A/LM340, LM7805C, LM7812C and LM7815C.

Output Impedance

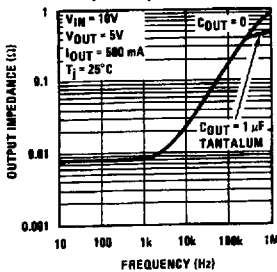

Dropout Characteristics

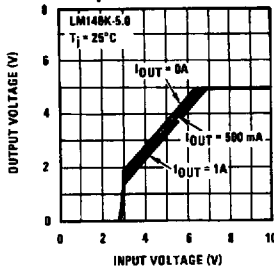

Quiescent Current

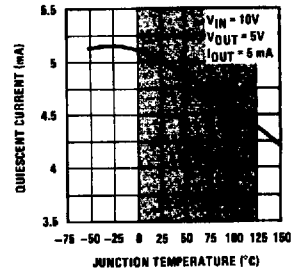

Note: Shaded area refers to LM340A/LM340, LM7805C, LM7812C and LM7815C.

Dropout Voltage

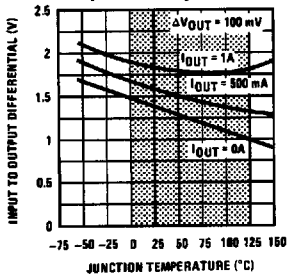

Note: Shaded area refers to LM340A/LM340, LM7805C, LM7812C and LM7815C.

Quiescent Current

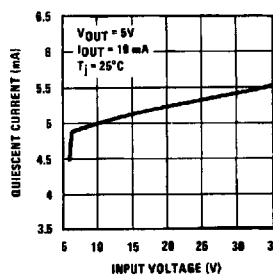

TL/H/7781-4

LM140A/LM140/LM340A/LM340/LM7800/LM7800C

Typical Performance Characteristics (Continued)

Load Regulation
140AK-5.0, $V_{IN} = 10V$, $T_A = 25^\circ C$

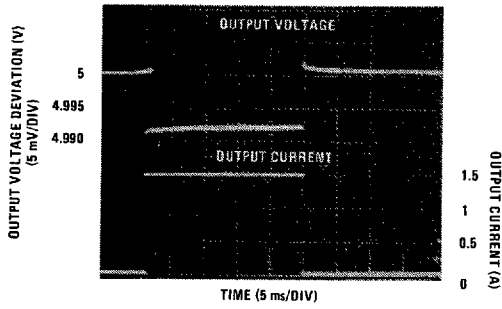

TL/H/7781-5

Line Regulation
140AK-5.0, $I_{OUT} = 1A$, $T_A = 25^\circ C$

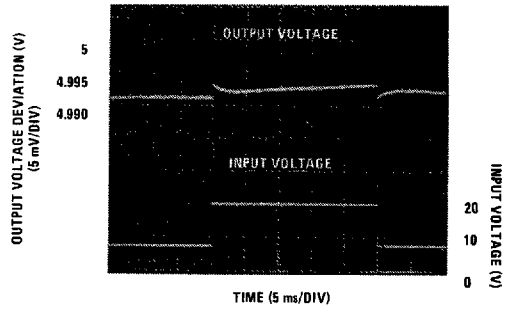

TL/H/7781-6

Equivalent Schematic

NATL SEMICOND (LINEAR)

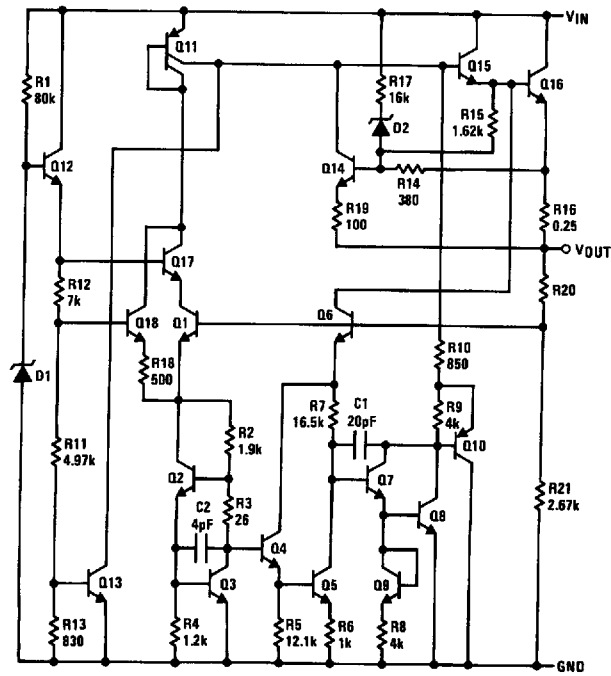

TL/H/7781-7

Application Hints

The LM340/LM78XX series is designed with thermal protection, output short-circuit protection and output transistor safe area protection. However, as with *any* IC regulator, it becomes necessary to take precautions to assure that the regulator is not inadvertently damaged. The following describes possible misapplications and methods to prevent damage to the regulator.

Shorting the Regulator Input: When using large capacitors at the output of these regulators, a protection diode connected input to output (*Figure 1*) may be required if the input is shorted to ground. Without the protection diode, an input short will cause the input to rapidly approach ground potential, while the output remains near the initial V_{OUT} because of the stored charge in the large output capacitor. The capacitor will then discharge through a large internal input to output diode and parasitic transistors. If the energy released by the capacitor is large enough, this diode, low current metal and the regulator will be destroyed. The fast diode in *Figure 1* will shunt most of the capacitors discharge current around the regulator. Generally no protection diode is required for values of output capacitance $\leq 10 \mu\text{F}$.

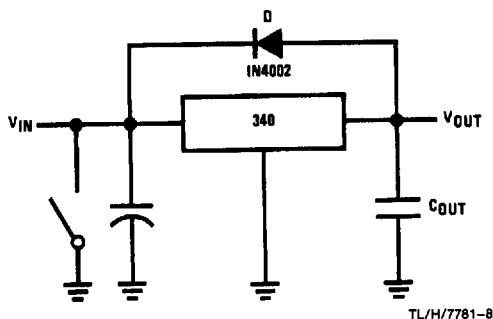

FIGURE 1. Input Short

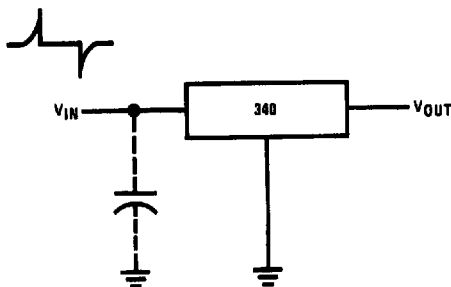

FIGURE 3. Transients

NATL SEMICOND (LINEAR)

Raising the Output Voltage above the Input Voltage: Since the output of the device does not sink current, forcing the output high can cause damage to internal low current paths in a manner similar to that just described in the "Shorting the Regulator Input" section.

Regulator Floating Ground (*Figure 2*): When the ground pin alone becomes disconnected, the output approaches the unregulated input, causing possible damage to other circuits connected to V_{OUT} . If ground is reconnected with power "ON", damage may also occur to the regulator. This fault is most likely to occur when plugging in regulators or modules with on card regulators into powered up sockets. Power should be turned off first, thermal limit ceases operating, or ground should be connected first if power must be left on.

Transient Voltages: If transients exceed the maximum rated input voltage of the device, or reach more than 0.8V below ground and have sufficient energy, they will damage the regulator. The solution is to use a large input capacitor, a series input breakdown diode, a choke, a transient suppressor or a combination of these.

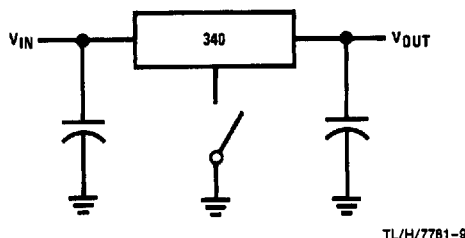

FIGURE 2. Regulator Floating Ground

LM140A/LM140/LM340A/LM340/LM7800/LM7800C

Typical Applications

NATL SEMICOND (LINEAR)

Fixed Output Regulator

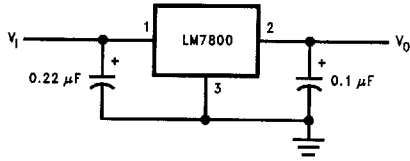

TL/H/7781-13

Note 1: Bypass capacitors are recommended for optimum stability and transient response, and should be located as close as possible to the regulator.

High Input Voltage Circuits

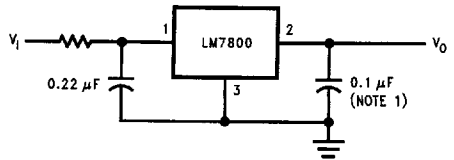

TL/H/7781-14

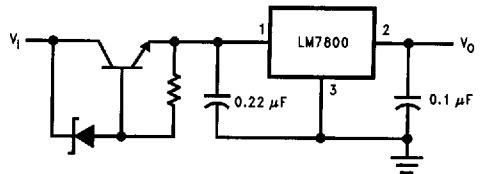

TL/H/7781-15

High Current Voltage Regulator

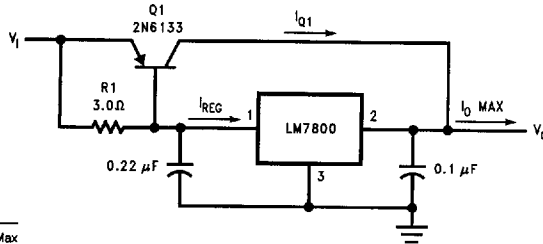

$$\beta(Q1) \geq \frac{I_{O \text{ Max}}}{I_{REG \text{ Max}}}$$

$$R1 = \frac{0.9}{I_{REG}} = \frac{\beta(Q1) V_{BE(Q1)}}{I_{REG \text{ Max}} (\beta + 1) - I_{O \text{ Max}}}$$

TL/H/7781-16

High Output Current, Short Circuit Protected

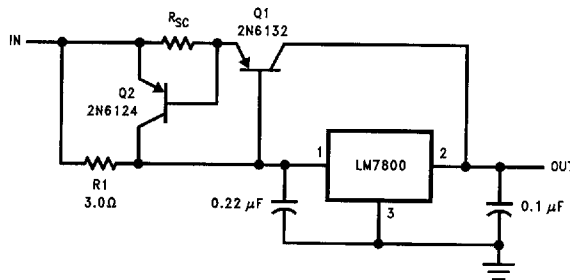

$$R_{SC} = \frac{0.8}{I_{SC}}$$

$$R1 = \frac{\beta V_{BE(Q1)}}{I_{REG \text{ Max}} (\beta + 1) - I_{O \text{ Max}}}$$

TL/H/7781-17

Positive and Negative Regulator

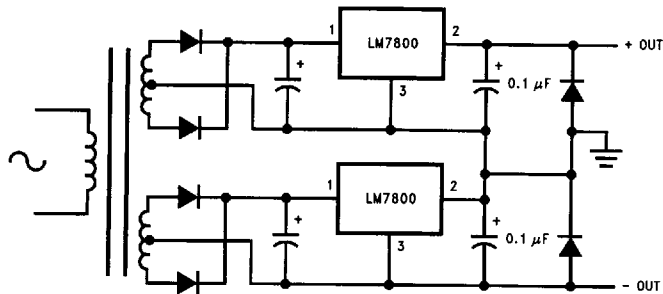

TL/H/7781-18

Connection Diagrams and Ordering Information

TO-3 Metal Can Package (K and KC)

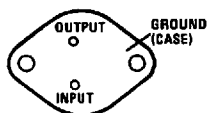

Bottom View

TL/H/7781-11

NATL SEMICOND (LINEAR)

TO-220 Power Package (T)

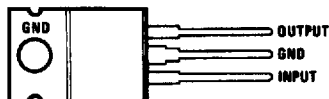

Top View

TL/H/7781-12

Steel Package Order Numbers:

LM140AK-5.0	LM140AK-12	LM140AK-15
LM140K-5.0	LM140K-12	LM140K-15
LM140AK-5.0/883	LM140AK-12/883	LM140AK-15/883
LM140K-5.0/883	LM140K-12/883	LM140K-15/883
LM340AK-5.0	LM340AK-12	LM340AK-15
LM340K-5.0	LM340K-12	LM340K-15
LM7806CK	LM7808CK	LM7808K
LM7818CK	LM7818K	LM7824CK
	LM7824K	

See Package Number K02A

Plastic Package Order Numbers:

LM340AT-5.0	LM340T-5.0
LM340AT-12	LM340T-12
LM340AT-15	LM340T-15
LM7805CT	LM7812CT
LM7815CT	LM7806CT
LM7808CT	LM7818CT
LM7824CT	

See Package Number T03B

Aluminum Package Order Numbers:

LM340KC-5.0
LM340KC-12
LM340KC-15
LM7805CK
LM7812CK
LM7815CK

See Package Number KC02A

TO-39 Metal Can Package (H)

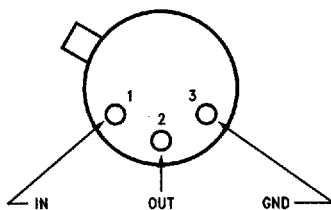

Top View

TL/H/7781-19

Metal Can Order Numbers†:

LM140H-5.0/883	LM140H-6.0/883
LM140H-8.0/883	LM140H-12/883
LM140H-15/883	LM140H-24/883

See Package Number H03A

†The specifications for the LM140H/883 devices are not contained in this datasheet. If specifications for these devices are required, contact the National Semiconductor Sales Office/Distributors.