

THIS COPY IS PROVIDED ON A RESTRICTED BASIS AND IS NOT TO BE USED IN ANY WAY DETRIMENTAL TO THE INTERESTS OF PANDUIT CORP.

PART NUMBER		TAB SIZE	WIRE RANGE mm ²	DIMENSIONS mm		
PREFIX	PK			A ±,38	B ±,25	C ±,25
DMNF1-488F1B	-C -M	4,8 X 0,8 (.187 X .032)	0,5-1,0 (22-18)	19,8 (.78)	7,9 (.31)	5,5 (.22)
DMNF1-63F1B	-C -M	6,3 X 0,8 (.250 X .032)	0,5-1,0 (22-18)	21,3 (.84)	8,9 (.35)	5,5 (.22)

NOTES:

- USED FOR:
 - 600V MAX. VOLTAGE RATING.
 - 105° C (221°F) MAX. TEMP. RATING
 - STRANDED COPPER WIRE ONLY.
- PACKAGE QTY:
 - STD: C=100
 - BULK: M=1000
- MATERIAL:
 - STAMPING: CDA 260 BRASS, TIN PLATED
 - HOUSING: TYPE 6/6 NYLON, TRANSLUCENT RED
- WIRE STRIP LENGTH: 7,1^{+ ,8} (9/32^{+ 1/32})
- FIRST INSERTION FORCE: 53N (12 LB.) MAX
FIRST WITHDRAWAL FORCE: 53N (12 LB.) MAX
27N (6 LB.) MIN
- INSTALLATION TOOLS: REF. DWGS.
A41522, A41523, A41524, A41525
- DIMENSIONS IN BRACKETS ARE IN INCHES OR AWG.

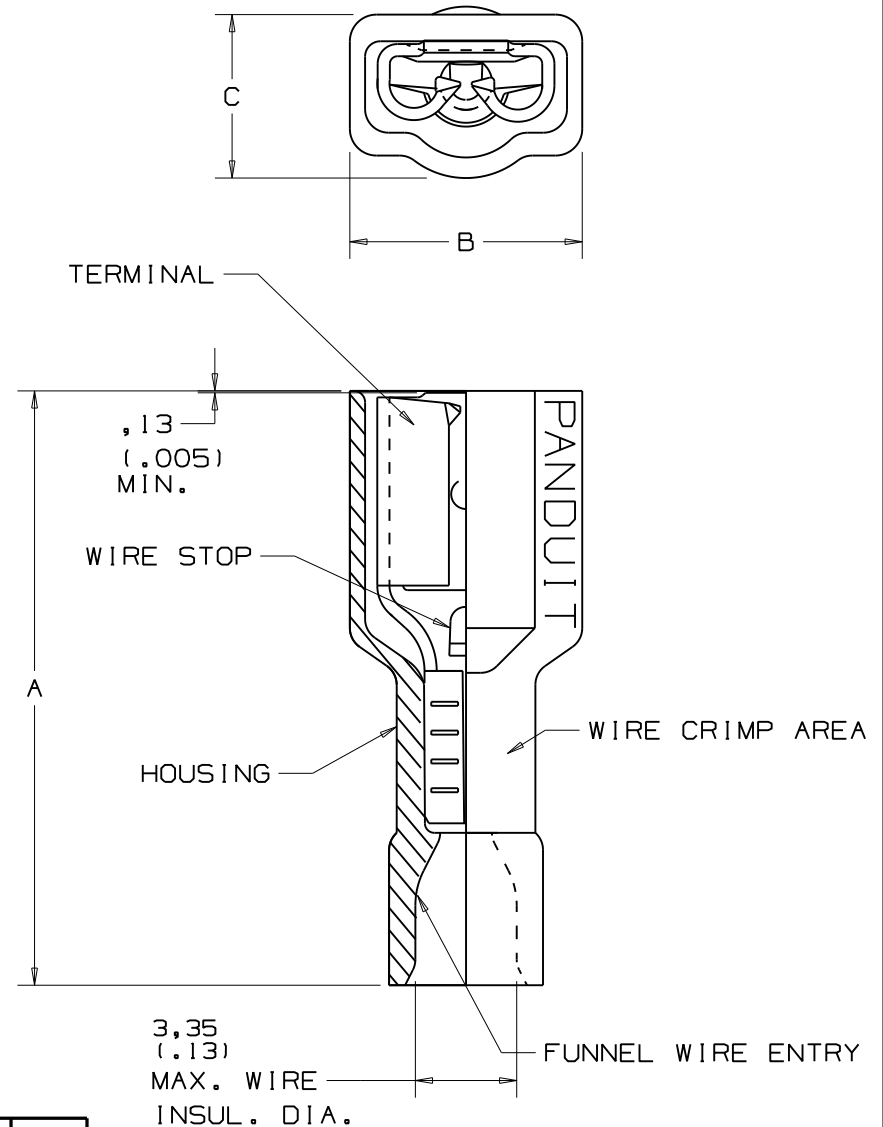

07	12/08	BCT		MODIFIED PART DMNF1-48F1B TO DMNF1-488F1B		TRO	
06	4/05	JHNU		REVISED DRAWING TITLE: 1,0mm WAS 1,5mm.			
05	7/03	KLFU	SKB	ADDED INTERNAL SERRATIONS WIRE RANGE 1,0 WAS 1,5	12453	TRO	SKB
04	1/01	RM	SKB	FILESPEC WAS N41504AA_PCD_03	8933	JAC	CCH
03	10-97	JAMB		CHANGED PERIODS TO COMMAS ON ALL METRIC DIMENSIONS.	06433		
REV	DATE	BY	CHK	DESCRIPTION	ECN #	PM	CUST

PANDUIT

CORP.

TINLEY PARK, ILLINOIS

0,5 - 1,0 mm ; 4,8² / 6,3 TAB
METRIC FULLY INSULATED FEMALE DISCONNECT

DRAWN BY	CHK'D	SCALE	DRAWING NO./CAD FILENAME
JMV	LSM	NONE	A41504