

20A SBR[®]
Super Barrier Rectifier

NEW PRODUCT

Features

- Low Forward Voltage Drop
- Excellent High Temperature Stability
- Super Barrier Design
- Soft, Fast Switching Capability
- Molded Plastic TO-220AB, D²Pak, and ITO-220AB packages
- **Lead Free Finish, RoHS Compliant (Note 2)**

Mechanical Data

- Case Material: Molded Plastic, UL Flammability Classification Rating 94V-0
- Moisture Sensitivity: Level 1 per J-STD-020C
- Terminals: Matte Tin Finish annealed over Copper leadframe. Solderable per MIL-STD-202, Method 208 **(e3)**
- Marking: See Page 4
- Ordering Information: See Page 4

Maximum Ratings @ T_A = 25°C unless otherwise specified

Single phase, half wave, 60Hz, resistive or inductive load.
For capacitive load, derate current by 20%.

Characteristic	Symbol	Value	Unit
Peak Repetitive Reverse Voltage	V _{RRM}	100	V
Working Peak Reverse Voltage	V _{RWM}		
DC Blocking Voltage	V _{RM}		
RMS Reverse Voltage	V _{R(RMS)}	71	V
Average Rectified Output Current @ T _C = 150°C	I _O	20	A
Non-Repetitive Peak Forward Surge Current 8.3ms Single Half Sine-Wave Superimposed on Rated Load	I _{FSM}	150	A
Peak Repetitive Reverse Surge Current (2uS-1KHz)	I _{RRM}	2	A
Maximum Thermal Resistance (per leg)	R _{θJC}	2	°C/W
Package = TO-220AB & D ² Pak			
Package = ITO-220AB		4	
Operating and Storage Temperature Range	T _J , T _{STG}	-65 to +175	°C

Electrical Characteristics @ T_A = 25°C unless otherwise specified

Characteristic	Symbol	Min	Typ	Max	Unit	Test Condition
Reverse Breakdown Voltage (Note 1)	V _{(BR)R}	100	-	-	V	I _R = 0.1 mA
Forward Voltage Drop	V _F	-	0.67	0.82 0.75	V	I _F = 10A, T _J = 25°C I _F = 10A, T _J = 125°C
Leakage Current (Note 1)	I _R	-	-	0.1 10	mA	V _R = 100V, T _J = 25 °C V _R = 100V, T _J = 125 °C

Notes:

1. Short duration pulse test used to minimize self-heating effect.
2. RoHS revision 13.2.2003. High temperature solder exemption applied, see *EU Directive Annex Note 7*.

SBR is a registered trademark of Diodes Incorporated.

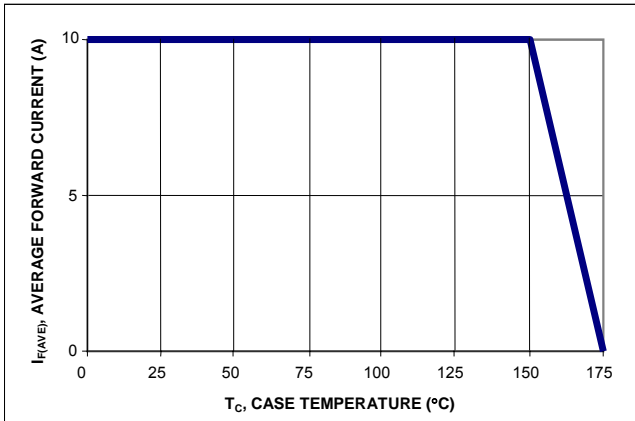

Figure 1: Current Derating Curve, Per Element

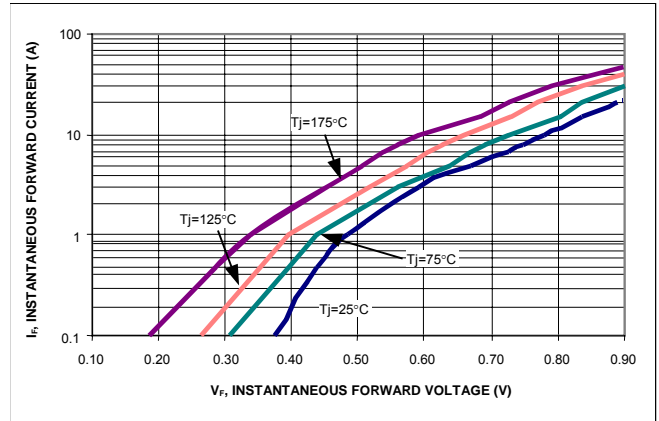

Figure 2: Typical Forward Characteristics, Per Element

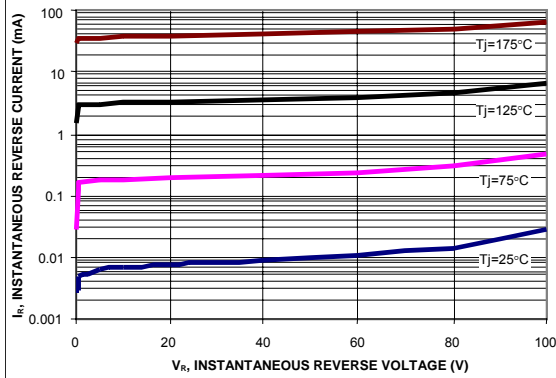
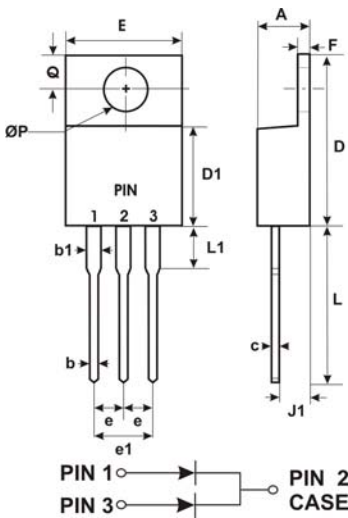

Figure 3: Typical Reverse Characteristics, Per Element

Package Outline Drawings

TO-220AB



TO-220AB		
DIM.	MIN.	MAX.
A	4.47	4.67
b	0.71	0.91
b1	1.17	1.37
c	0.31	0.53
D	14.65	15.35
D1	8.50	8.90
E	10.01	10.31
e	2.54 typ	
e1	4.98	5.18
F	1.17	1.37
J1	2.52	2.82
L	13.40	13.80
L1	3.56	3.96
ØP	3.735	3.935
Q	2.59	2.89

All Dimensions in Millimeters

ITO-220AB

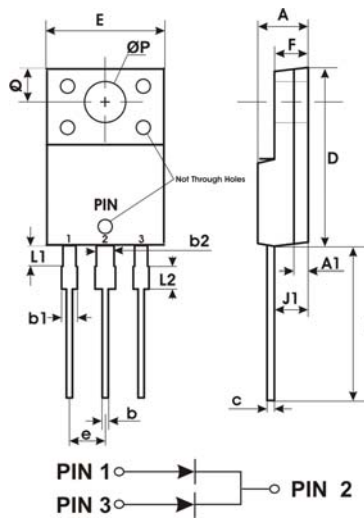

ITO-220AB		
DIM.	MIN.	MAX.
A	4.30	4.70
b	0.50	0.75
b1	1.10	1.35
b2	1.50	1.75
c	0.50	0.75
D	14.80	15.20
E	9.96	10.36
e	2.54 typ	
F	2.80	3.20
J1	2.50	2.90
L	12.80	13.60
L1	1.70	1.90
ØP	3.50 typ	
Q	2.70 typ	

All Dimensions in Millimeters

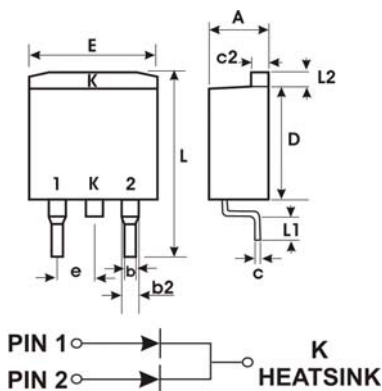

D²PAK



D ² PAK		
DIM.	MIN.	MAX.
A	4.40	4.80
b	0.76	1.00
b2	1.17	1.47
c	0.36	0.50
c2	1.25	1.45
D	8.60	9.00
E	9.80	10.40
e	2.54 typ	
L	14.60	15.80
L1	2.29	2.79
L2	1.27 typ	

All Dimensions in Millimeters

Marking, Polarity, Weight & Ordering Information

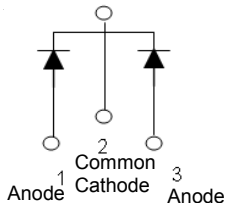
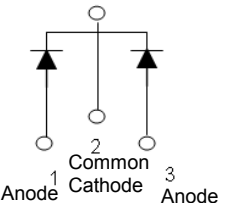
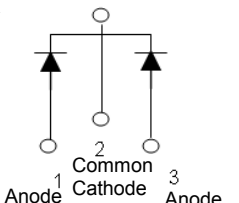
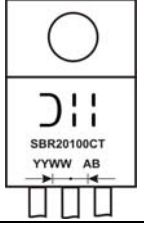
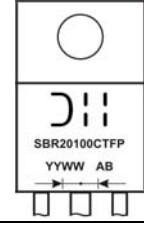
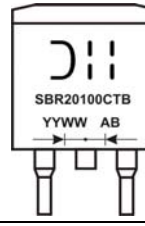
	SBR20100CT	SBR20100CTFP	SBR20100CTB
Case Style	 TO-220AB	 ITO-220AB	 D ² PAK
Polarity	<p>Case</p>  <p>Anode 1 2 Common 3 Cathode</p>	<p>Case</p>  <p>Anode 1 2 Common 3 Cathode</p>	<p>Case</p>  <p>Anode 1 2 Common 3 Cathode</p>
Marking			
Weight	2.1g	1.9g	1.6g

Ordering Information	SBR20100CT 50 pieces/tube	SBR20100CTFP 50 pieces/tube	SBR20100CTB 50 pieces/tube
Date Code	YY = Last two digits of year, ex = 06 = 2006 WW = Week (01-52)		
Other Marking Information	A = Foundry Code B = Assembly Code		

IMPORTANT NOTICE

Diodes Incorporated and its subsidiaries reserve the right to make modifications, enhancements, improvements, corrections or other changes without further notice to any product herein. Diodes Incorporated does not assume any liability arising out of the application or use of any product described herein; neither does it convey any license under its patent rights, nor the rights of others. The user of products in such applications shall assume all risks of such use and will agree to hold Diodes Incorporated and all the companies whose products are represented on our website, harmless against all damages.

LIFE SUPPORT

Diodes Incorporated products are not authorized for use as critical components in life support devices or systems without the expressed written approval of the President of Diodes Incorporated.