

Maxi, Mini, Micro DC-DC Converters Parallel Bus: PR Pin

Application Engineering
Vicor Corporation
December 2008



Parallel Operation

A unique feature has been designed into Vicor's Brick Maxi, Mini, and Micro converter modules which facilitates parallel operation for power expansion or redundancy. The "PR" pin is a bidirectional port that transmits and receives information between modules. The pulse signal on the parallel (PR) bus serves to synchronize the high frequency switching of each converter which in turn forces them to load share. These modules possess the ability to arbitrate the leadership role; i.e., a democratic array. The module that assumes command transmits the sync pulse on the parallel bus while all other modules on the bus listen.

Load Share Bus Connections

AC coupled single-wire interface. All PR pins are connected to a single communication bus through 0.001µF (500 V) capacitors. Negative In pins must be tied to the same electric potential. This interface supports current sharing and is fault tolerant except for the communication bus, see Figure 1.

Transformer coupled interface. Modules or arrays of modules may also be interfaced to share a load while providing galvanic isolation between PR pins via a transformer coupled interface, see Figure 2. For large arrays, or long signal lines (>30 cm), buffering may be required. The power source for the buffer circuit may be derived from PC pins. Many applications may benefit from the addition of Z1 in series with the PR pin of each converter. A low Q 33 Ω @ 100 Mhz ferrite bead or a 5 - 15 Ohm resistor may be used to improve the PR signal waveform.

Figure 1.
AC coupled single-wire interface

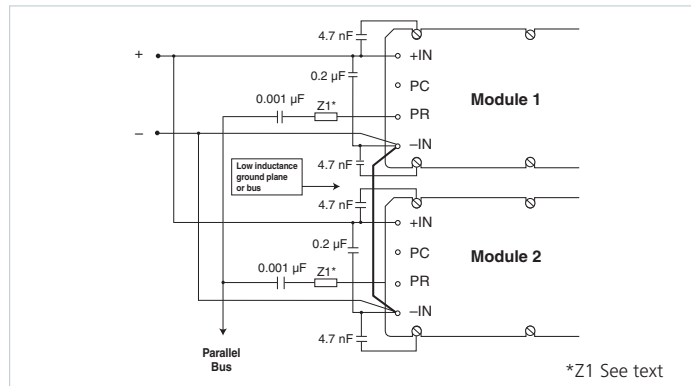
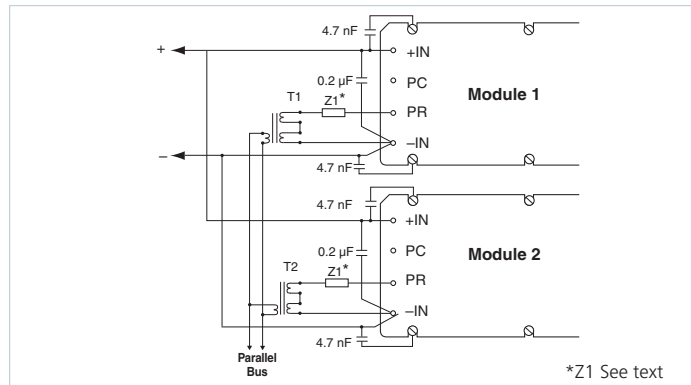

Figure 2.
Transformer coupled interface



Parallel Operation Considerations

Care must be taken to avoid introducing interfering signals (noise) onto the parallel bus as this may prevent proper load sharing between modules. One possible source of interference is input ripple current conducted via the plus and minus input power pins. The PR signal and DC power input share a common return which is the negative input pin. Steps should be taken to de-couple AC components of input current from the parallel bus. The input to each converter (designated as + and - pins on the input side of the module) should be bypassed locally with a 0.2 μF ceramic or film capacitor. This provides a shunt path for input ripple current. A Y-rated 4.7 nF capacitor should be connected between the +IN pin and the baseplate, and -IN pin and the baseplate of each module, thus creating a shunt path for common mode components of current. Attention to the PC board artwork should minimize the parasitic impedance between negative input pins of parallel modules to insure that all PR pins are referenced to the same potential. Modules should be placed physically close to each other and wide copper traces (0.75 in., 2 oz. copper) should be used to connect power input pins. A dedicated layer of copper is the ideal solution. Care should be exercised to minimize shunt capacitance on the PR bus.

Some applications require physical separation of paralleled modules on different boards, and/or input power from separate sources. In these cases, transformer coupling of the PR signal is required to prevent inter-module common mode "bounce" from interfering with the sync pulse transmission. High speed buffering may be required with large arrays or if the distance between modules is greater than a few inches. This is due to the fact that all modules, except the one that's talking, are in the listening mode. Each listener presents a load to the master (talker) which is approximately 500 Ohms shunted by 30 pf capacitance. Long leads for the interconnection introduce losses and parasitic reactance on the bus which can attenuate and distort the sync pulse signal. The bandwidth of the bus must be at least 60 MHz and the signal attenuation less than 2 db. In most cases transformer coupling without buffering is adequate. A transformer is available (Vicor P/N 29768) for parallel bus interface that provides SELV isolation and 3000 Vrms dielectric withstand between windings. This transformer (Figure 3) is trifilar wound, 1:1:1 turns ratio. Two winding are connected in series as illustrated in (Figure 3) for connection to the module and the third windings provides the isolated bus interface. Again careful attention must be given to layout considerations.

For further information on Brick Maxi, Mini, Micro DC-DC Converters Parallel Bus, PR Pin, call Vicor Applications Engineering at 800-927-9474, or e-mail apps@vicorpower.com.

Figure 3.
PR Bus Isolation Transformer,
part #29768

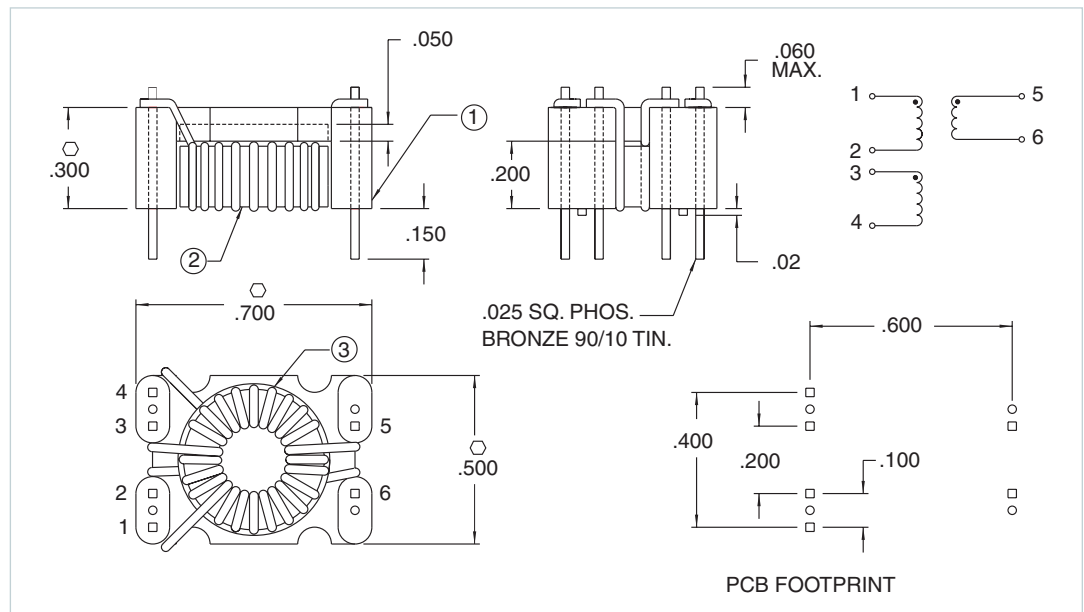

The Power Behind Performance