

Product Overview

AR0134CS: CMOS Image Sensor, Digital, Global Shutter, 1.2 MP, 1/3"

For complete documentation, see the [data sheet](#).

ON Semiconductor's focus on pixel performance excellence provides the foundation for this sensor's exceptional image quality with superior performance. The sensor integrates ON Semiconductor's smallest, high performance global shutter technology for high speed image capture into a 1/3-inch optical format high definition (HD) device. The 3.75-micron global shutter pixel with exceptional low light performance can stop action without the artifacts typically associated with conventional rolling shutter pixels.

Features

- ON Semiconductor's 3rd Generation Global Shutter Technology
- Superior low-light performance
- HD video (720p60)
- Video/Single Frame mode
- Flexible row-skip modes
- On-chip AE and statistics engine
- Parallel and serial output
- Support for external LED or flash
- Auto black level calibration
- Context switching

For more features, see the [data sheet](#)

Part Electrical Specifications

Product	Pricing (\$/Unit)	Compliance	Status	Type	Megapixels	Frame Rate (fps)	Optical Format	Shutter Type	Pixel Size (µm)	Output Interface	Color	Package Type
AR0134CSSC00SPCA0-DPBR		Pb-free Halide free	Active	CMOS	1.2	54	1/3 inch	Global Shutter	3.75 x 3.75	Parallel HiSPi™	RGB	ILCC-48
AR0134CSSC00SPCA0-DRBR		Pb-free Halide free	Active	CMOS	1.2	54	1/3 inch	Global Shutter	3.75 x 3.75	HiSPi™ Parallel	RGB	ILCC-48
AR0134CSSC00SPCA0-TPBR		Pb-free Halide free	Active	CMOS	1.2	54	1/3 inch	Global Shutter	3.75 x 3.75	HiSPi™ Parallel	RGB	ILCC-48
AR0134CSSC00SPCA0-TRBR		Pb-free Halide free	Active	CMOS	1.2	54	1/3 inch	Global Shutter	3.75 x 3.75	Parallel HiSPi™	RGB	ILCC-48
AR0134CSSC00SPD20		Pb-free Halide free	Active	CMOS	1.2	54	1/3 inch	Global Shutter	3.75 x 3.75	HiSPi™ Parallel	RGB	
AR0134CSSC00SUEA0-DPBR		Pb-free Halide free	Active	CMOS	1.2	54	1/3 inch	Global Shutter	3.75 x 3.75	HiSPi™ Parallel	RGB	IBGA-63
AR0134CSSC00SUEA0-DPBR1		Pb-free Halide free	Active	CMOS	1.2	54	1/3 inch	Global Shutter	3.75 x 3.75	HiSPi™ Parallel	RGB	IBGA-63
AR0134CSSC00SUEA0-DRBR		Pb-free Halide free	Active	CMOS	1.2	54	1/3 inch	Global Shutter	3.75 x 3.75	HiSPi™ Parallel	RGB	IBGA-63
AR0134CSSC00SUEA0-TPBR		Pb-free Halide free	Active	CMOS	1.2	54	1/3 inch	Global Shutter	3.75 x 3.75	Parallel HiSPi™	RGB	IBGA-63
AR0134CSSC00SUEA0-TRBR		Pb-free Halide free	Active	CMOS	1.2	54	1/3 inch	Global Shutter	3.75 x 3.75	Parallel HiSPi™	RGB	IBGA-63
AR0134CSSM00SPCA0-DPBR		Pb-free Halide free	Active	CMOS	1.2	54	1/3 inch	Global Shutter	3.75 x 3.75	Parallel HiSPi™	Mono	ILCC-48
AR0134CSSM00SPCA0-DPBR1		Pb-free Halide free	Active	CMOS	1.2	54	1/3 inch	Global Shutter	3.75 x 3.75	Parallel HiSPi™	Mono	ILCC-48
AR0134CSSM00SPCA0-DRBR		Pb-free Halide free	Active	CMOS	1.2	54	1/3 inch	Global Shutter	3.75 x 3.75	HiSPi™ Parallel	Mono	ILCC-48
AR0134CSSM00SPCA0-TPBR		Pb-free Halide free	Active	CMOS	1.2	54	1/3 inch	Global Shutter	3.75 x 3.75	HiSPi™ Parallel	Mono	ILCC-48
AR0134CSSM00SPCA0-TRBR		Pb-free Halide free	Active	CMOS	1.2	54	1/3 inch	Global Shutter	3.75 x 3.75	Parallel HiSPi™	Mono	ILCC-48
AR0134CSSM00SPD20		Pb-free Halide free	Active	CMOS	1.2	54	1/3 inch	Global Shutter	3.75 x 3.75	HiSPi™	Mono	
AR0134CSSM00SUEA0-DPBR		Pb-free Halide free	Active	CMOS	1.2	54	1/3 inch	Global Shutter	3.75 x 3.75	Parallel HiSPi™	Mono	IBGA-63
AR0134CSSM00SUEA0-DPBR1		Pb-free Halide free	Active	CMOS	1.2	54	1/3 inch	Global Shutter	3.75 x 3.75	HiSPi™ Parallel	Mono	IBGA-63
AR0134CSSM00SUEA0-DRBR		Pb-free Halide free	Active	CMOS	1.2	54	1/3 inch	Global Shutter	3.75 x 3.75	HiSPi™ Parallel	Mono	IBGA-63
AR0134CSSM00SUEA0-TPBR		Pb-free Halide free	Active	CMOS	1.2	54	1/3 inch	Global Shutter	3.75 x 3.75	HiSPi™ Parallel	Mono	IBGA-63
AR0134CSSM00SUEA0-TRBR		Pb-free Halide free	Active	CMOS	1.2	54	1/3 inch	Global Shutter	3.75 x 3.75	HiSPi™ Parallel	Mono	IBGA-63
AR0134CSSM25SPCA0-TPBR		Pb-free Halide free	Active	CMOS	1.2	54	1/3 inch	Global Shutter	3.75 x 3.75	HiSPi™ Parallel	Mono	ILCC-48
AR0134CSSM25SPD20		Pb-free Halide free	Active	CMOS	1.2	54	1/3 inch	Global Shutter	3.75 x 3.75	HiSPi™ Parallel	Mono	
AR0134CSSM25SUEA0-DPBR		Pb-free Halide free	Active	CMOS	1.2	54	1/3 inch	Global Shutter	3.75 x 3.75	HiSPi™ Parallel	Mono	IBGA-63
AR0134CSSM25SUEA0-DRBR		Pb-free Halide free	Active	CMOS	1.2	54	1/3 inch	Global Shutter	3.75 x 3.75	Parallel HiSPi™	Mono	IBGA-63
AR0134CSSM25SUEA0-DRBR1		Pb-free Halide free	Active	CMOS	1.2	54	1/3 inch	Global Shutter	3.75 x 3.75	Parallel HiSPi™	Mono	IBGA-63

AR0134CSSM25SUEA0-TPBR	Pb-free Halide free	Active	CMOS	1.2	54	1/3 inch	Global Shutter	3.75 x 3.75	HiSPi™ Parallel	Mono	IBGA-63
AR0134CSSM25SUEA0-TRBR	Pb-free Halide free	Active	CMOS	1.2	54	1/3 inch	Global Shutter	3.75 x 3.75	HiSPi™ Parallel	Mono	IBGA-63

Application Diagram

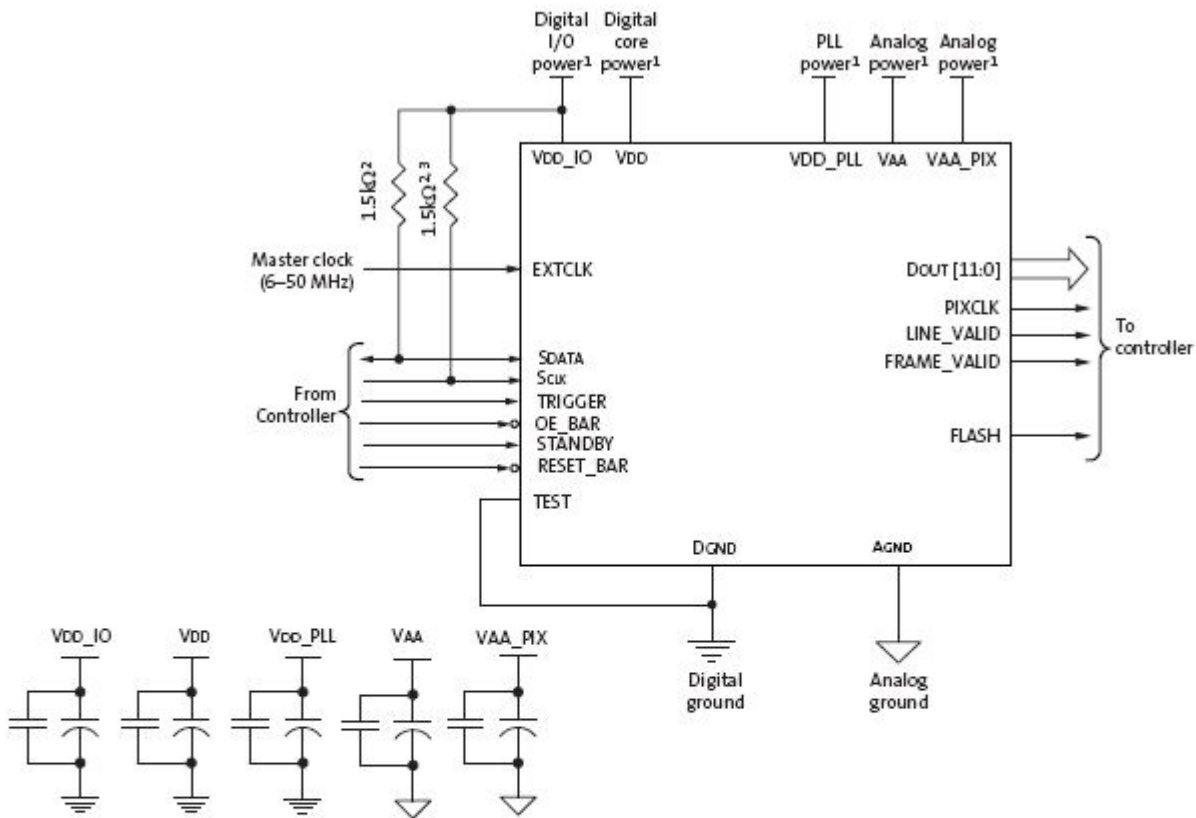

- Notes:
1. All power supplies must be adequately decoupled.
 2. ON Semiconductor recommends a resistor value of 1.5k Ω , but it may be greater for slower two-wire speed.
 3. This pull-up resistor is not required if the controller drives a valid logic level on SCLK at all times.
 4. The serial interface output pads can be left unconnected if the parallel output interface is used.
 5. ON Semiconductor recommends that 0.1 μ F and 10 μ F decoupling capacitors for each power supply are mounted as close as possible to the pad. Actual values and results may vary depending on layout and design considerations. Refer to the AR0134 demo headboard schematics for circuit recommendations.
 6. ON Semiconductor recommends that analog power planes be placed in a manner such that coupling with the digital power planes is minimized.

For more information please contact your local sales support at www.onsemi.com.

Created on: 5/27/2020