

Male

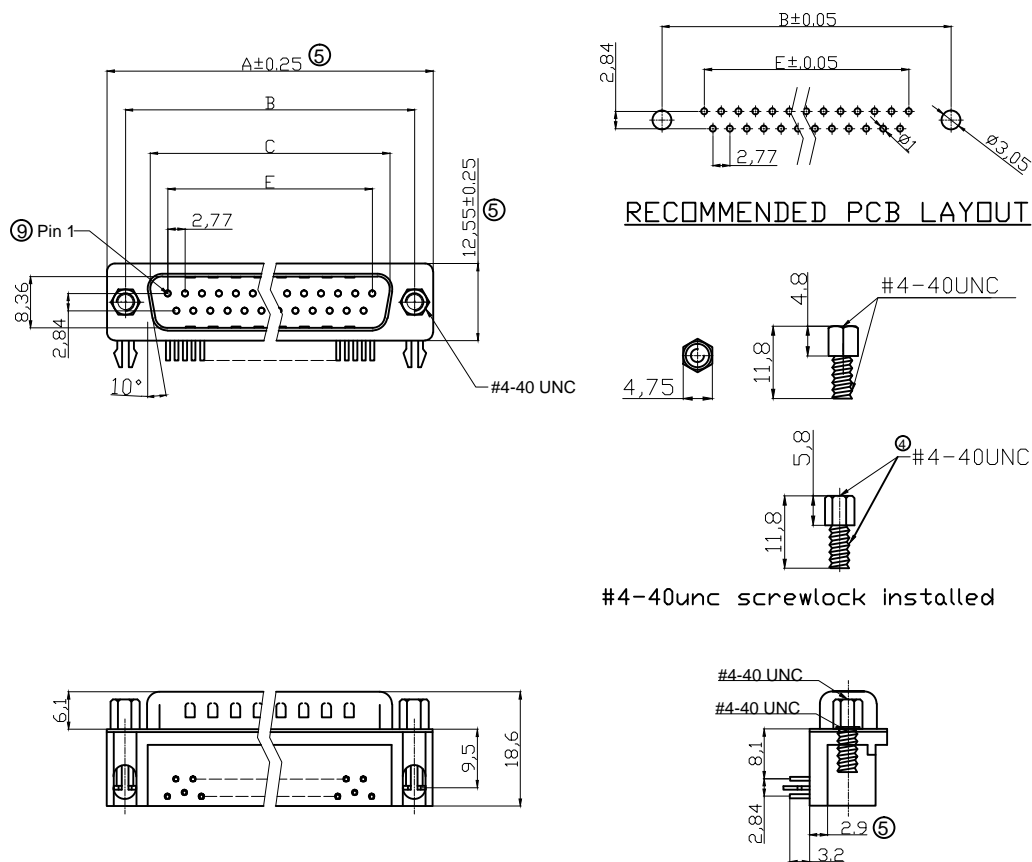

7.2mm Footprint

NOTES:

MATERIAL

- 1. Insulator Material: Glass-Filled Thermoplastic PBT ,UL 94V-0,Black
- 2. Contact Material : Brass
- ⑦ 3. Contact plating : See order code
- 4. Shell : Steel,100u" Tin over 50u" min copper
- 5. Clinch Nut : Copper alloy, Nickel plated
- 6. Boardlock : Brass , Tin plated
- 7. Screwlock : Steel, Nickel plated

ELECTRICAL

- 1. Current Rating : 3AMP
- 2. Voltage Rating : 250V AC/rms 60Hz
- 3. Contact Resistance: 20mΩ max at 1 AMP DC
- 4. Insulation Resistance: 1000MΩ at 500 V DC
- 5. Withstand Voltage : 1000V AC/rms 60Hz for 1 minute
- ② 6. Operating Temperature: -55°C~+105°C
- ⑩ 7. Mechanical Life Cycle:500 cycles

Order Code: A-Dx xx A/KG-xx \* on request

- Contact style: F - Female  
S - Male  
No. of Contacts 09 / 15 / 25 / 37
- Version  
T2 - with locking bolts UNC (Gold flash full gold)  
⑦ T2S - with locking bolts UNC (Gold flash selective Sn)  
T4 - without locking bolts \*(Gold flash full gold)  
③ T4-2 - without locking bolts \*(selective15u"Au for 9&15P)  
⑦ T4S - without locking bolts \* (Gold flash selective Sn)  
Standard: Quality class III  
⑧④ T2A - with UNC screw of 5.8mm, NON-UL (Gold flash full gold)

Dimensions

Positions	A	B	C	E
9	30.81	24.99	16.92	11.08
15	39.20	33.30	25.25	19.39
25	53.05	47.04	38.96	33.24
37	69.40	63.50	55.42	49.86

RoHS compliant

Unit: mm



Scale	Free	⑩	Added the mechanical life cycles	27.10.2023	Peter	Date	Name	Customer-No.
TOLERANCE		⑨	Marked the Pin 1	11.08.2023	Peter	Drawn	15.08.2012	Lucas
X.	±0.38	⑧	Update the specification of T2A	29.03.2022	Daniel	Approved	27.10.2023	Peter
X.X	±0.25	⑦	Update the description of plating	17.09.2021	Daniel			
X.XX	±0.13	⑥	Add UL logo	27.02.2020	Winnie			
DIM	TOL	⑤	Add insulator thickness, update tolerance and adjust profile	18.02.2019	Xavier			
X.°	±3°	Id.	Modification	Date	Name			ASSMANN WSWW-No. A-Dx xx A/KG-T2/T2S/T4/T4-2/T4S/T2A
X.X°	±1.0°							Drawing-No.
Angle	TOL					Replace		Sheet 1 / 2

**Female**

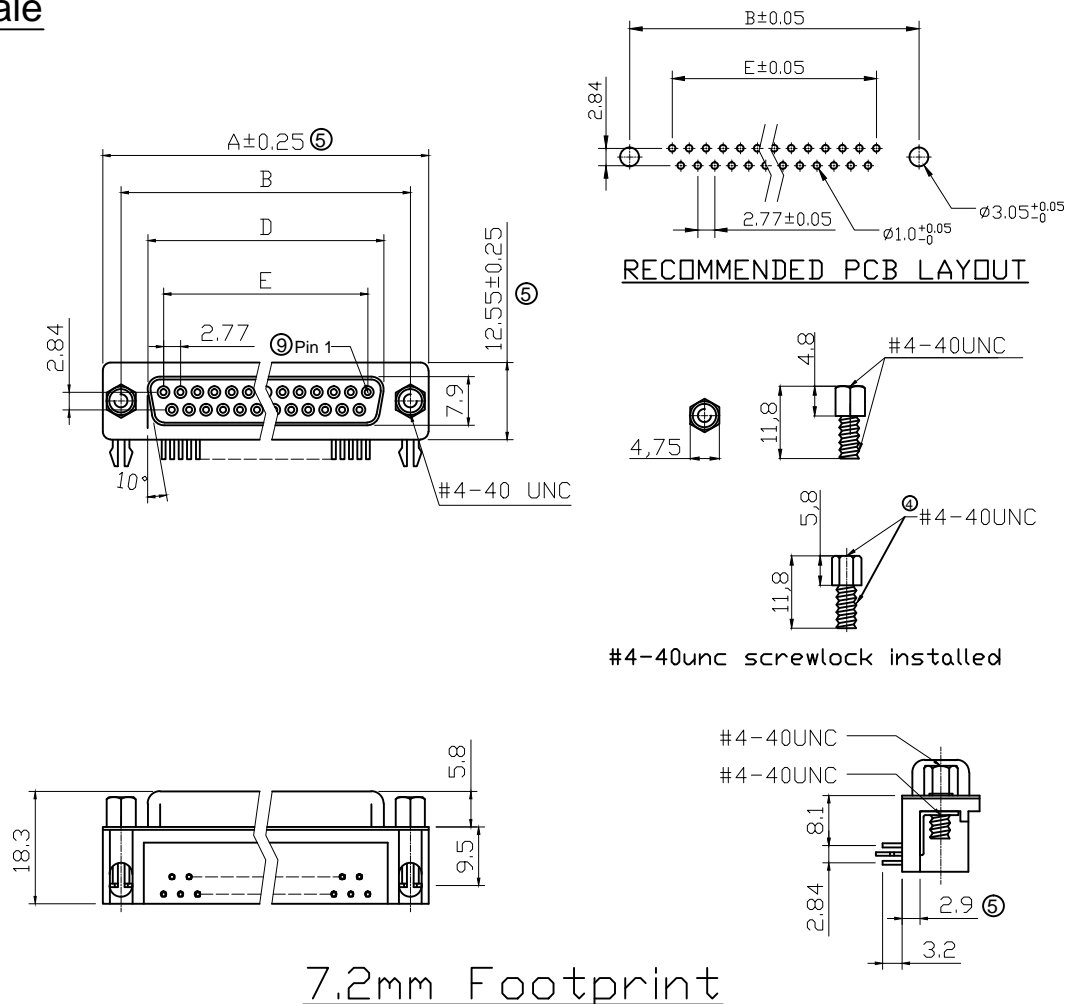

**NOTES:**

**MATERIAL**

- 1. Insulator Material: Glass-Filled Thermoplastic PBT ,UL 94V-0,Black
- 2. Contact Material : Copper alloy
- ⑦ 3. Contact plating : See order code
- 4. Shell : Steel,100u" Tin over 50u" min copper
- 5. Boardlock : Brass , Tin plated
- 6. Screwlock: Steel, Nickel plated

**ELECTRICAL**

- 1. Current Rating : 3AMP
- 2. Voltage Rating : 250V AC/rms 60Hz
- 3. Contact Resistance: 20mΩ max at 1 AMP DC
- 4. Insulation Resistance: 1000MΩ at 500 V DC
- 5. Withstand Voltage : 1000V AC/rms 60Hz for 1 minute
- ② 6. Operating Temperature: -55°C~+105°C
- ⑩ 7. Mechanical Life Cycle:500 cycles

Order Code: A-Dx xx A/KG-xx \* on request

- Contact style: F - Female  
S - Male  
No. of Contacts 09 / 15 / 25 / 37
- Version  
T2 - with locking bolts UNC (Gold flash full gold)  
⑦ T2S - with locking bolts UNC (Gold flash selective Sn)  
T4 - without locking bolts \*(Gold flash full gold)  
③ T4-2 - without locking bolts \*(selective 15u" Au for 9&15P)  
⑦ T4S - without locking bolts \*(Gold flash selective Sn)  
Standard: Quality class III  
⑧④ T2A - with UNC screw of 5.8mm, NON-UL (Gold flash full gold)

**Dimensions**

Positions	A	B	D	E
9	30.81	24.99	16.33	11.08
15	39.20	33.30	24.70	19.39
25	53.05	47.04	38.40	33.24
37	69.40	63.50	54.80	49.86

7.2mm Footprint

**RoHS compliant**

Unit: mm



Scale	Free	⑩	Added the mechanical life cycles	27.10.2023	Peter	Date	Name	Customer-No.
<b>TOLERANCE</b>		⑨	Marked the Pin 1	11.08.2023	Peter	Drawn	15.08.2012	Lucas
X.	±0.38	⑧	Update the specification of T2A	29.03.2022	Daniel	Approved	27.10.2023	Peter
X.X	±0.25	⑦	Update the description of plating	17.09.2021	Daniel			
X.XX	±0.13	⑥	Add UL logo	27.02.2020	Winnie			
DIM	TOL	⑤	Add insulator thickness, update tolerance and adjust profile	18.02.2019	Xavier			
X.°	±3°	Id.	Modification	Date	Name			ASSMANN WSWW-No. A-Dx xx A/KG-T2/T2S/T4/T4-2/T4S/T2A
X.X°	±1.0°							Drawing-No.
Angle	TOL							rev10
								Replace
								Sheet 2 / 2



ASS 4888 CO  
rev10  
Sheet 2 / 2