



TAOGLAS®



Datasheet

Part No:
WDP.2458.25.4.B.02

Description:
Wi-Fi Dual-band 2.4/5 GHz
Embedded Ceramic Patch Antenna
6dBi+ at 2.4GHz
6dBi+ on 5 to 6 GHz

Features:
Dimensions: 25mm*25mm*4mm
2400MHz to 2500MHz/5150MHz to 5850MHz
Pin Type
Supports IEEE 802.11 Dual-band Wi-Fi systems
Dual linear polarization
Tuned for 70x70mm ground plane
RoHS and REACH Compliant

1. Introduction	3
2. Specifications	4
3. Antenna Characteristics	5
4. Radiation Patterns	7
5. Mechanical Drawing	9
6. Antenna Integration Guide	10
7. Mechanical Drawing – Evaluation Boar	15
8. Packaging	16
Changelog	17

Taoglas makes no warranties based on the accuracy or completeness of the contents of this document and reserves the right to make changes to specifications and product descriptions at any time without notice. Taoglas reserves all rights to this document and the information contained herein. Reproduction, use or disclosure to third parties without express permission is strictly prohibited.



1. Introduction



This unique patent pending high gain, high efficiency embedded ceramic patch antenna is designed for professional Wi-Fi dual-band IEEE 802.11 applications. It is mounted via pin and double-sided adhesive. The passive patch offers stable high gain response from 4 dBi to 6dBi on the 2.4GHz band and from 5dBi to 8dBi on the 5 ~6 GHz band. Efficiency values are impressive also across the bands with on average 60%+.

The WDP.25's high gain, high efficiency performance is the perfect solution for directional dual-band WiFi application which need long range but which want to use small compact embedded antennas. The much higher gain and efficiency of the WDP.25 over smaller less efficient more omni-directional chip antennas (these typically have no more than 2dBi gain, 30% efficiencies) means it can deliver much longer range over a wide sector.

Typical applications are

- Access Points
- Tablets
- High definition high throughput video streaming routers
- High data MIMO bandwidth routers
- Automotive
- Home and industrial in-wall WiFi automation
- Drones/Quad-copters
- UAV
- Long range WiFi remote control applications

The WDP patch antenna has two distinct linear polarizations, on the 2.4 and 5GHz bands, increasing isolation between bands.

Custom tuned versions for different ground-planes and housing environments can be made subject to a minimum order quantity.

Contact your regional Taoglas customer support team for further information or to integrate and test this antenna performance in your device.

2. Specifications

GNSS Electrical		
Frequency Range (MHz)	2400-2500	5150-5850
Return Loss (dB)	Min. -19, -2 at edge	<-5
Antenna Efficiency (%)	Max. 80, 25+ at edge	50+ in bands
Antenna Peak Gain (dBi)	6	8
Antenna Polarization	Linear	
Impedance	50 ohm	
Input Power	10W	
Mechanical		
Height	4 mm	
Planner Dimension	25 x 25 mm	
Environmental		
Frequency Temp Coefficient (Tf)	0±20ppm/°C	
Operating Temperature	-40°C to +105°C	
Humidity	Non-condensing 65°C 95% RH	

*All tests were done on a 70mm*70mm ground plane.



3. Antenna Characteristics

3.1 Return Loss

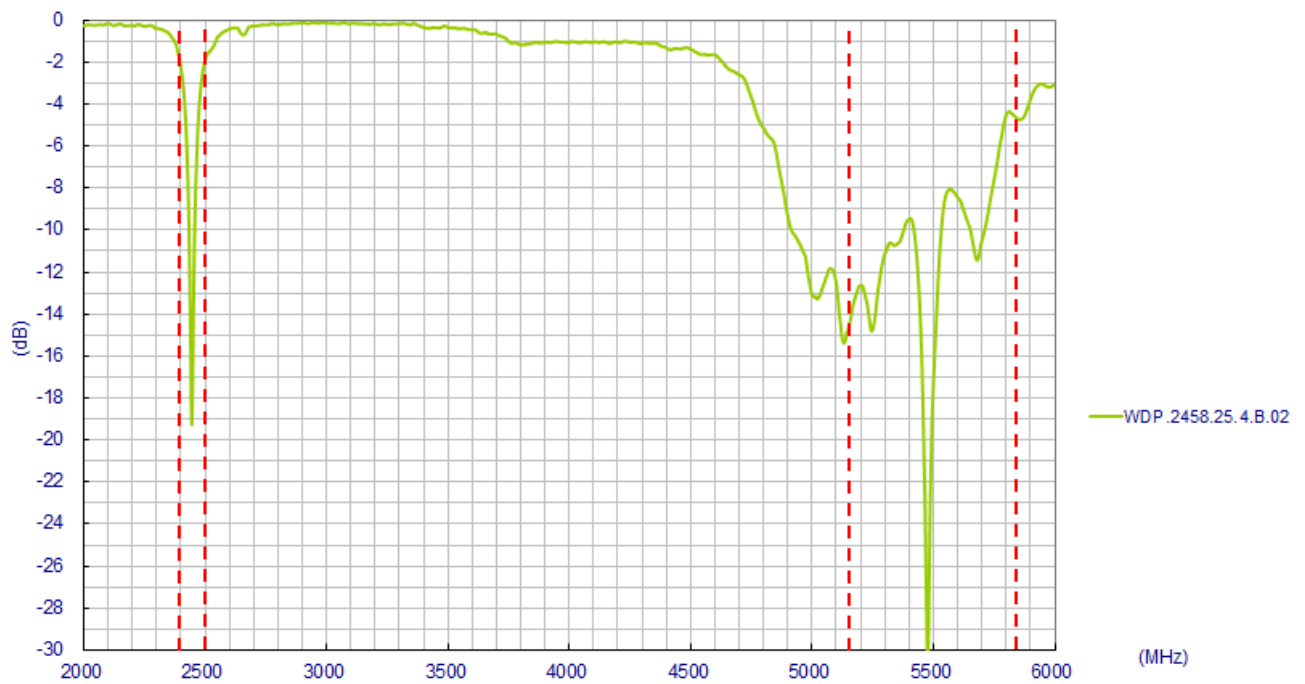

3.2 Peak Gain

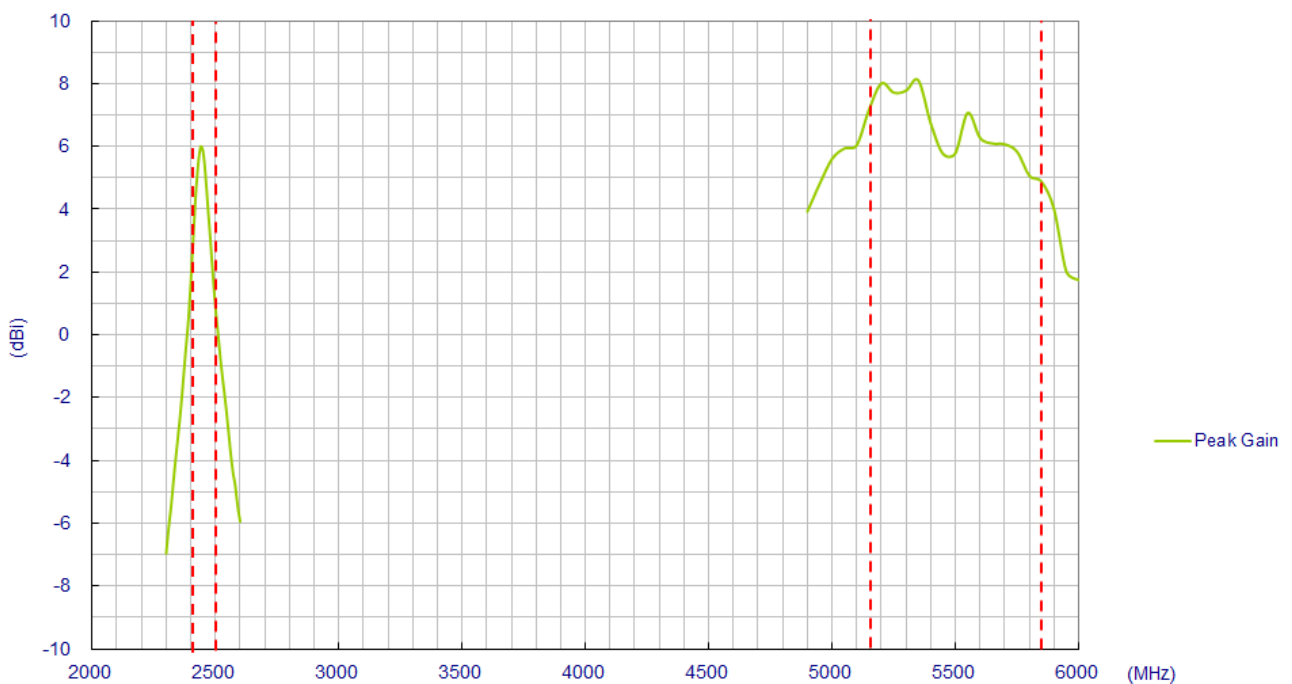

3.3 Average Gain Gain

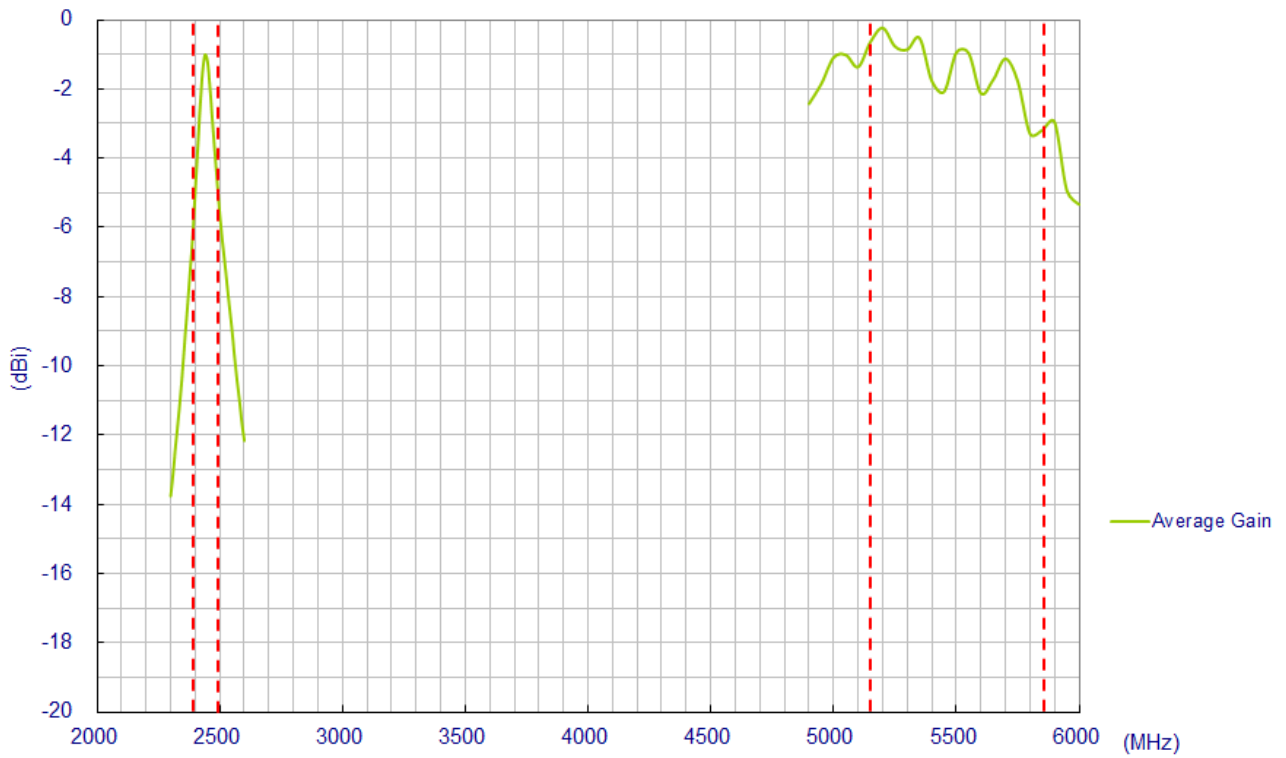

3.4 Efficiency

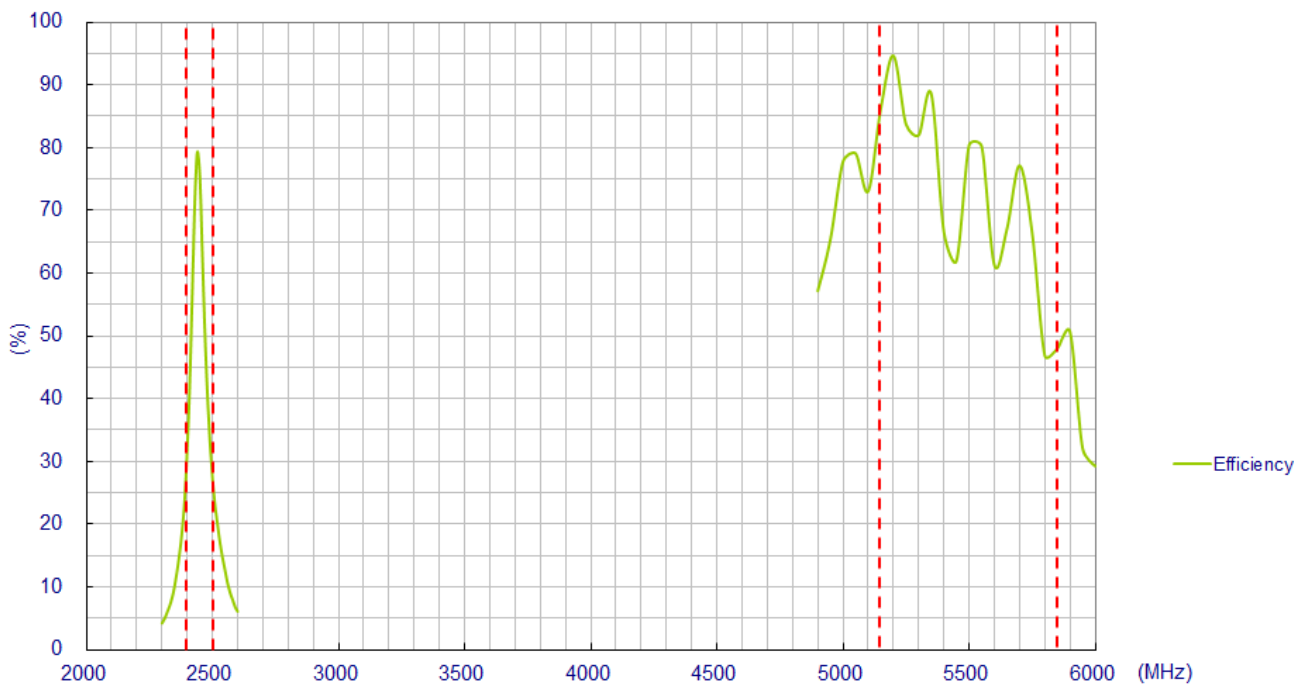

4. Radiation Patterns

4.1 Test Setup

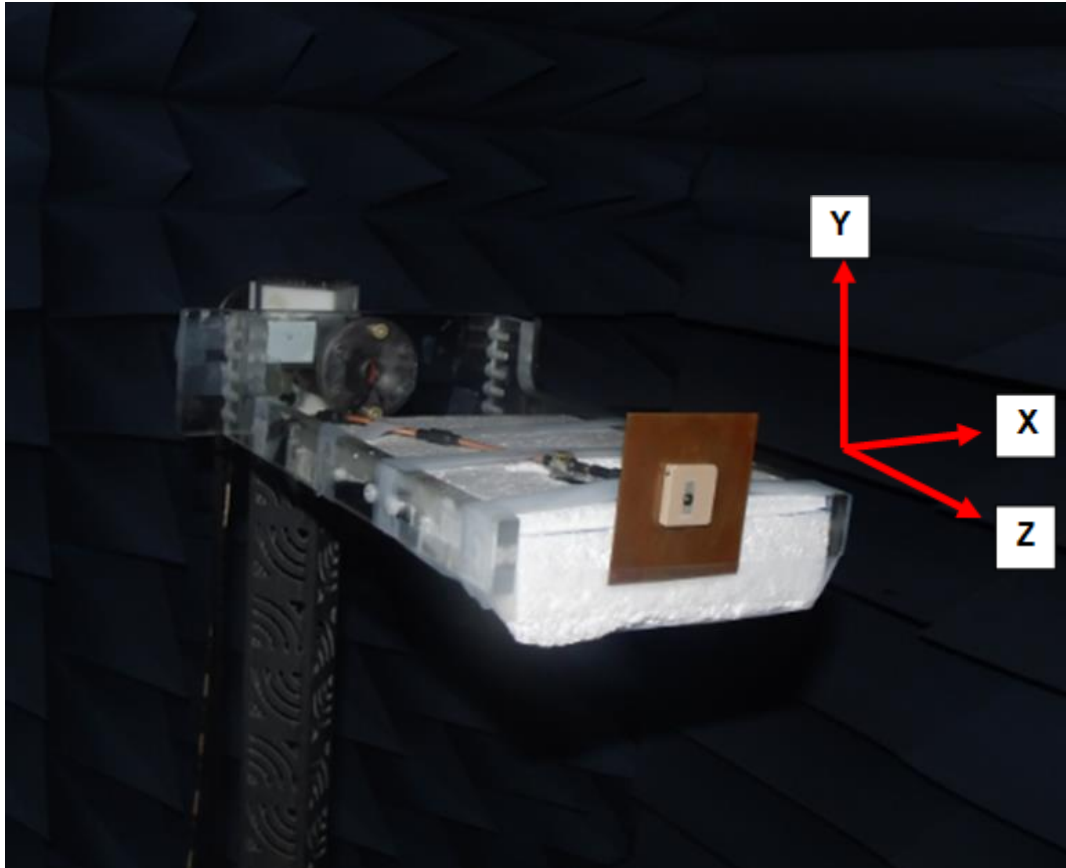

The antenna radiation pattern measurement setup as shown below,

4.2 2400MHz, 2450MHz & 2500MHz 2D Radiation Patterns

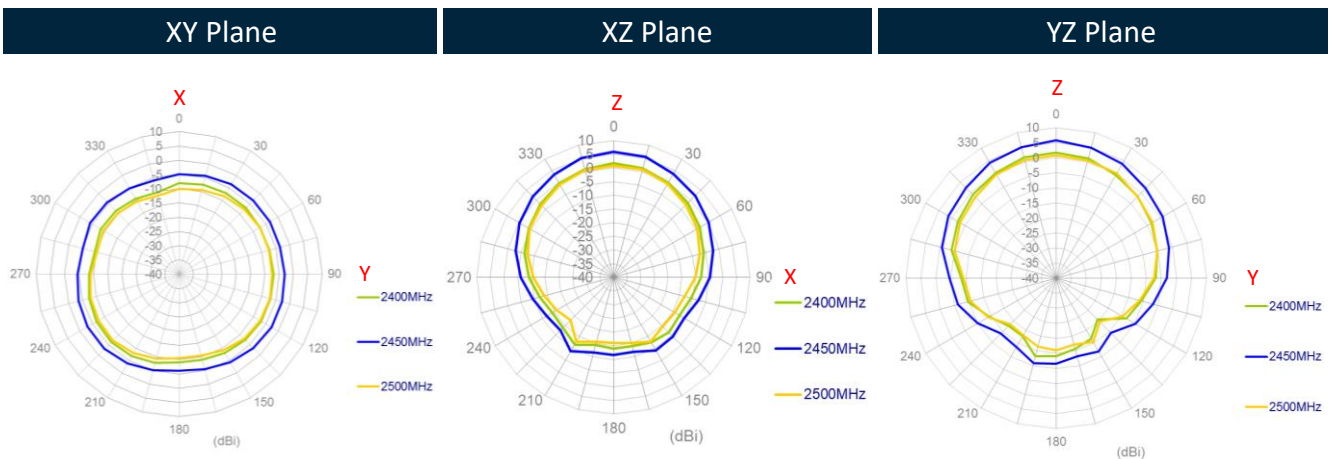

4.3 4900MHz, 5150MHz, 5550MHz & 5850MHz 2D Radiation Patterns

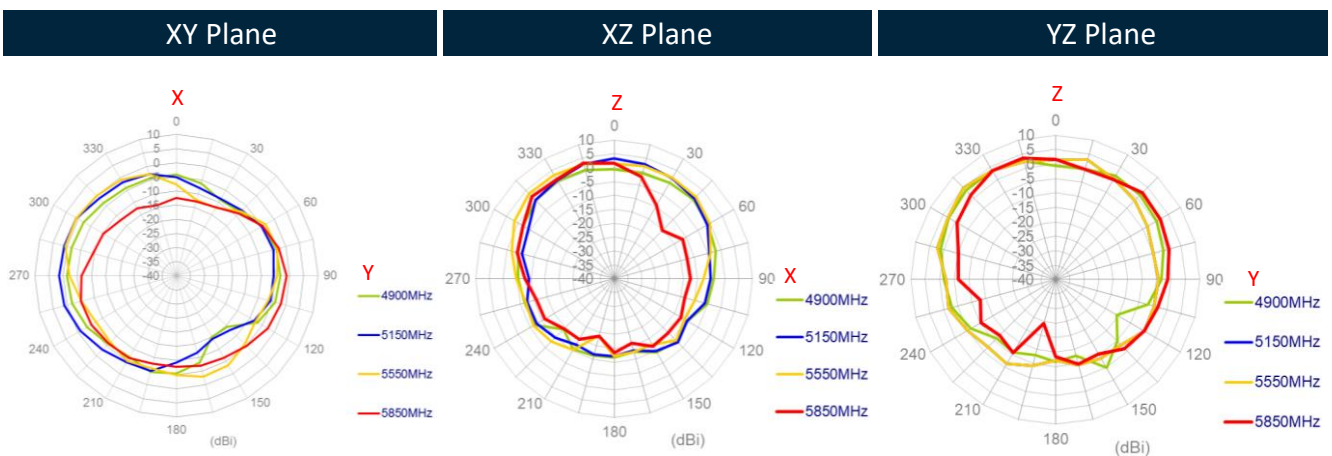

5. Mechanical Drawing (Units: mm)

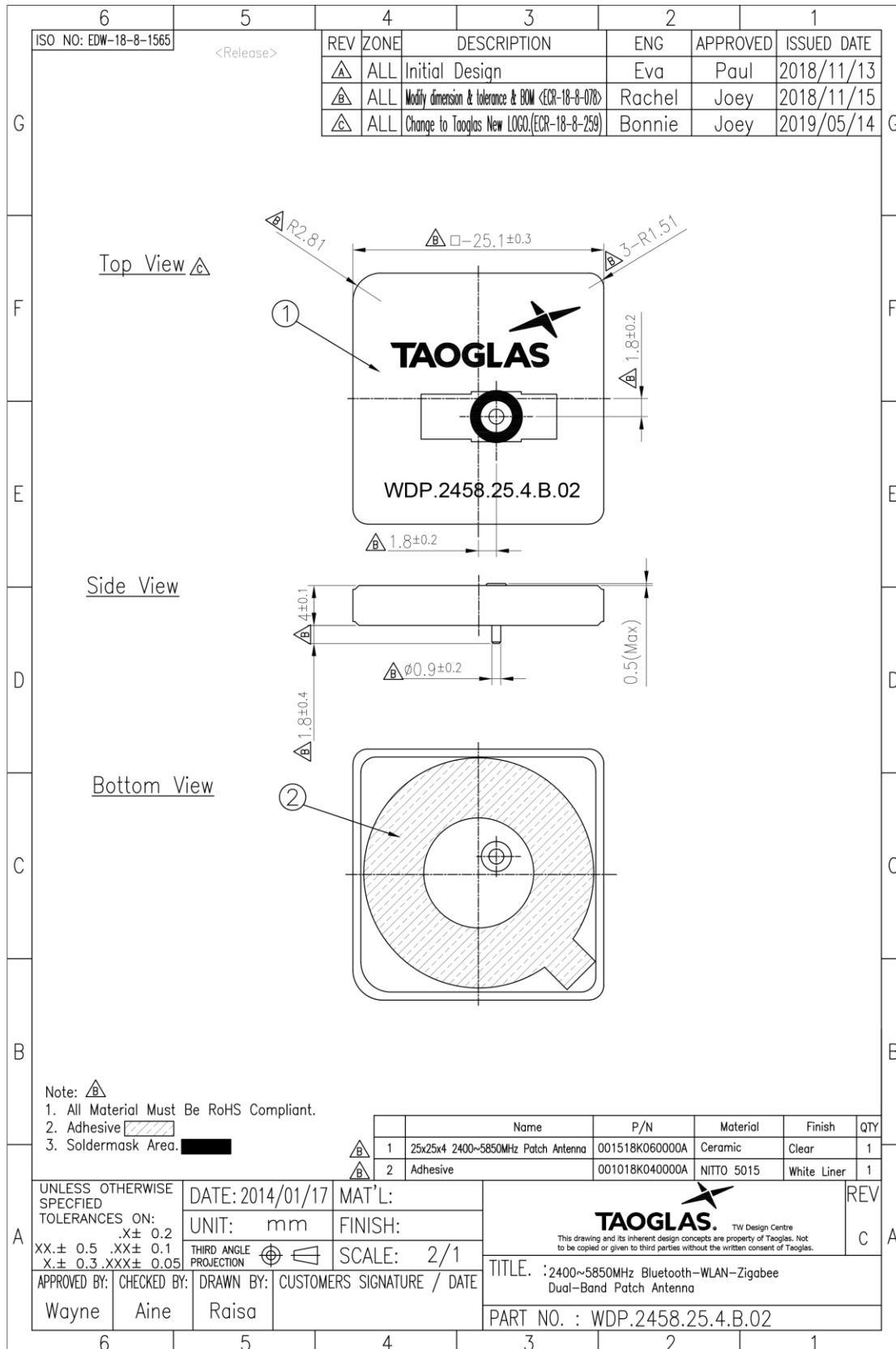

6. Antenna Integration Guide

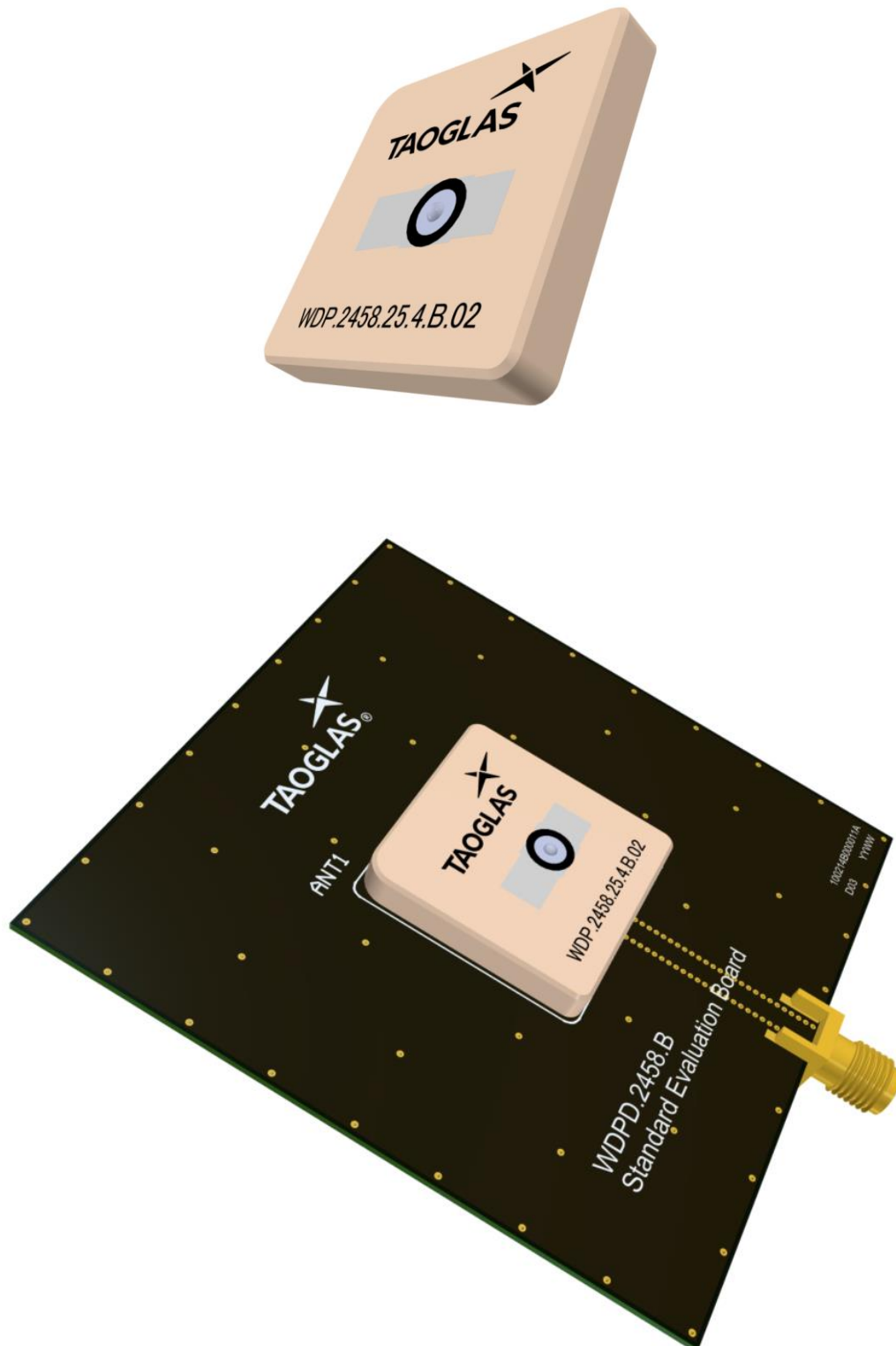

6.1 Schematic Symbol and Pin Definition

The circuit symbol for the antenna is shown below. The antenna has 1 pin as indicated below.

Pin	Description
1	RF Feed

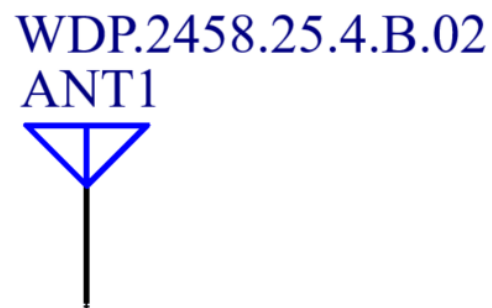

6.2 Antenna Integration

The antenna should be placed at the center of the ground plane with a length and width of 70mm. Maintaining a square symmetric ground plane shape and symmetric environment around the antenna is critical to maintaining the excellent axial ratio and phase center performance shown in this datasheet.



Top Side w/ Solder Mask

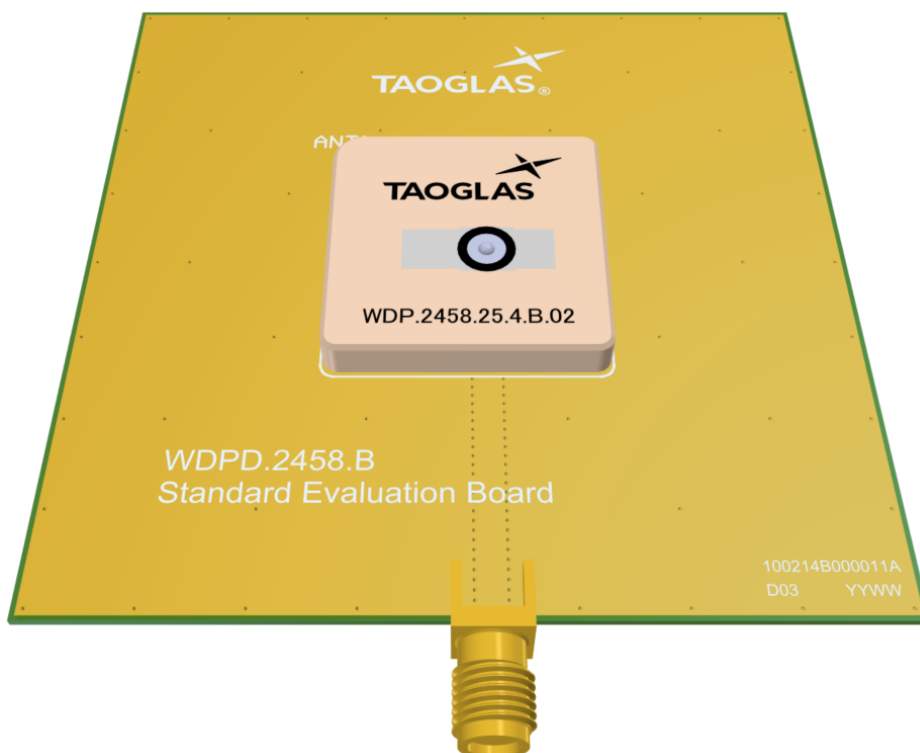

Top Side w/o Solder Mask

6.3 PCB Layout

The footprint and clearance on the PCB must comply with the antenna specification. The PCB layout shown in the diagram below demonstrates the antenna footprint.

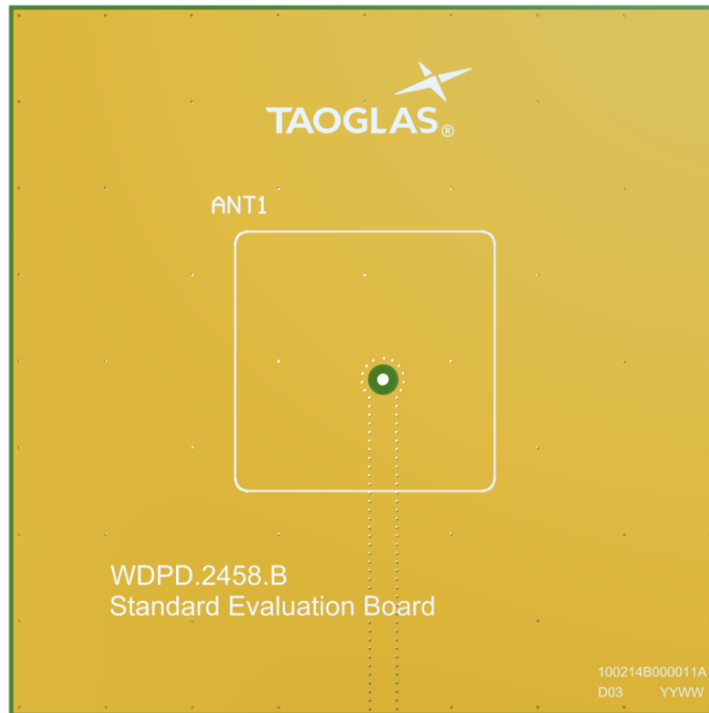

Topside

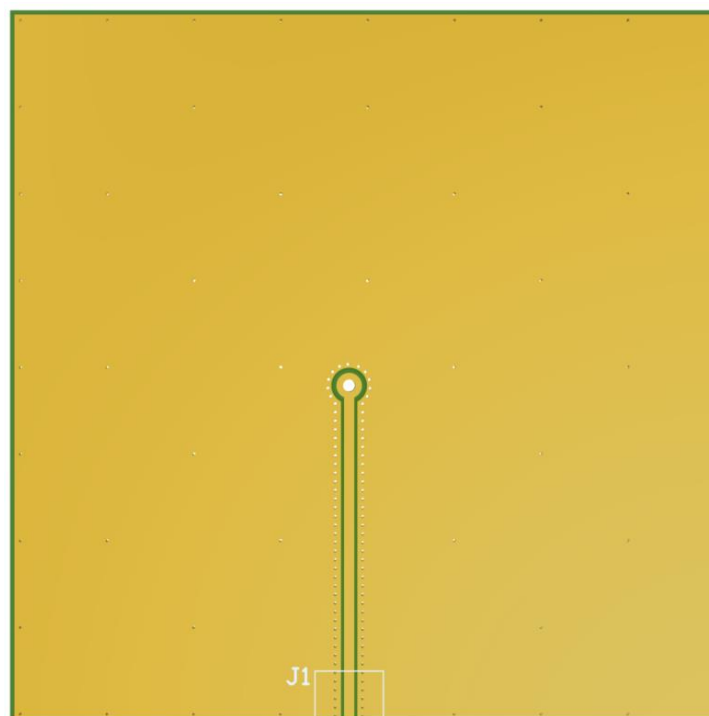

Bottom Side

6.5 Evaluation Board

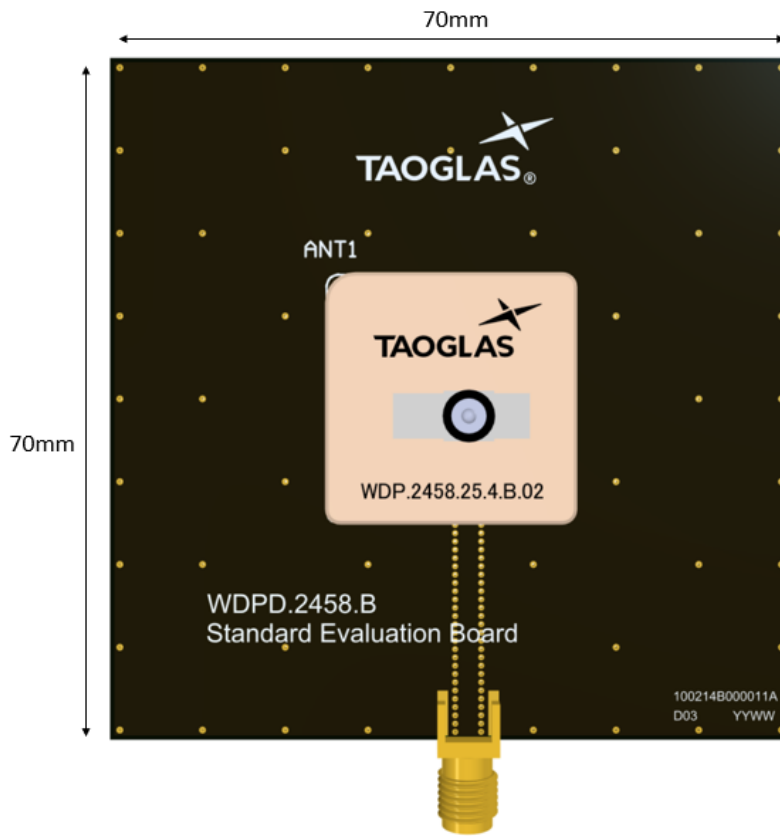

Topside

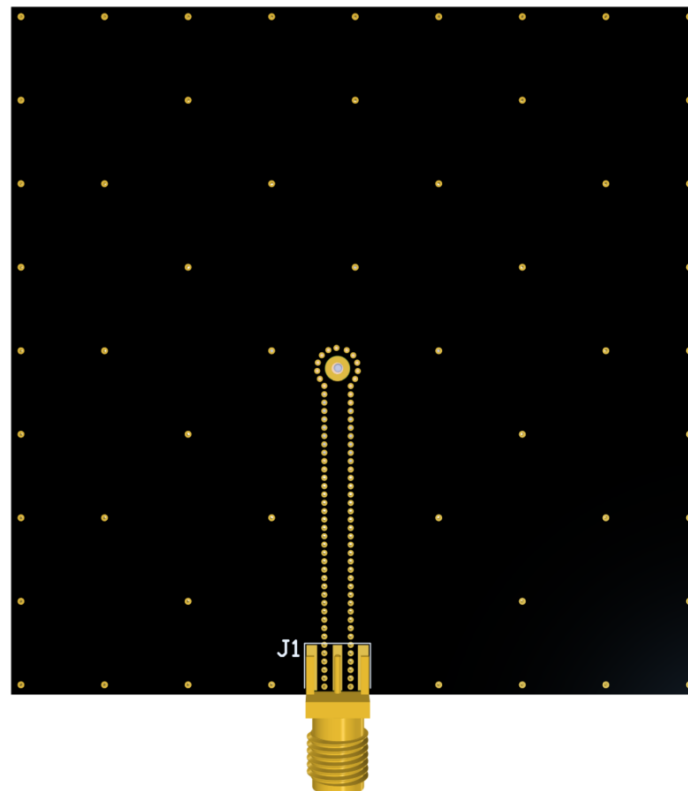

Bottom Side

7. Mechanical Drawing – Evaluation Board

Top View

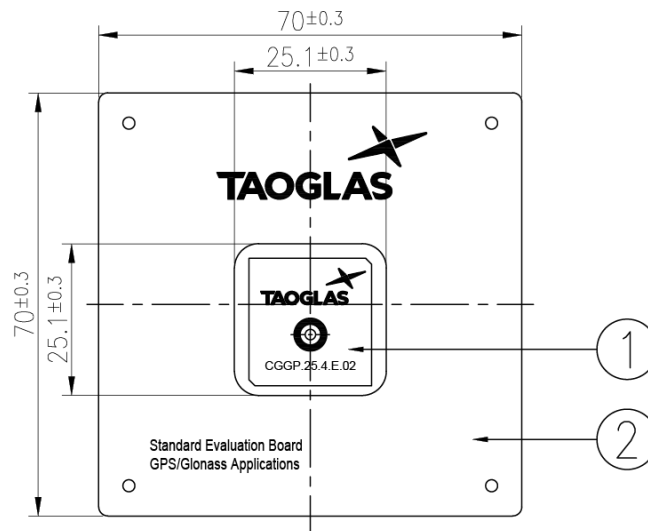

Side View

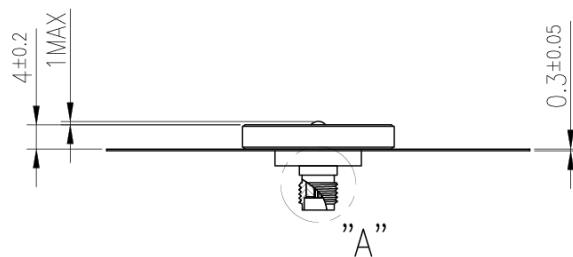

Bottom View

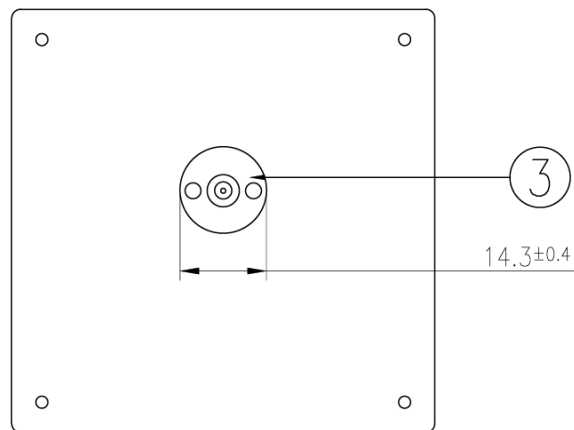

NOTE:

- 1.All material must be RoHS compliant.
- 2.Open/short QC, VSWR required.
- 3.Soldermask Area

	Name	P/N	Material	Finish	QTY
1	Patch	001515H040007A	Ceramic	Clear	1
2	Ground-Plane	000514B000007A	SPTe	Silver	1
3	SMA(F)ST	200419A000094A	Brass	Au Plated	1

8. Packaging

50 pcs WDP.2458.25.4.B.02 per tray
Tray Dimensions - 260*150mm

Weight - 223g

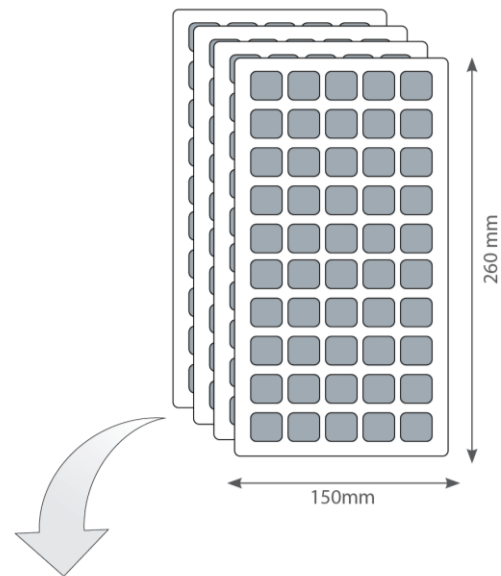

200 pcs WDP.2458.25.4.B.02 per Inner Carton
Inner Carton Dimensions - 261*152*118mm

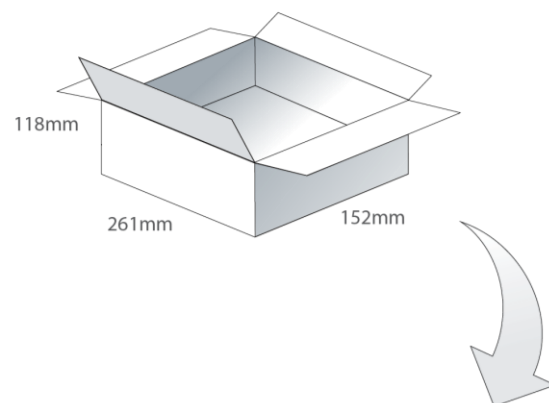

800 pcs WDP.2458.25.4.B.02 per Carton
Carton Dimensions - 370*370*300mm

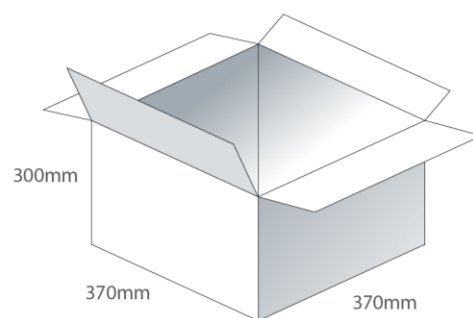

Changelog for the datasheet

SPE-14-8-039 – WDP.2458.25.4.B.02

Revision: E (Current Version)

Date:	2023-03-16
Changes:	Antenna Integration Guide
Changes Made by:	Cesar Sousa

Previous Revisions

Revision: D

Date:	2018-03-27
Changes:	Updated Datasheet Template Updated Packaging
Changes Made by:	Paul Doyle

Revision: C

Date:	2017-03-08
Changes:	Packaging Details Updated
Changes Made by:	Made by Andy Mahoney

Revision: B

Date:	2017-08-17
Changes:	Packaging Details Updated
Changes Made by:	Andy Mahoney

Revision: A (Original First Release)

Date:	2017-08-10
Notes:	
Author:	Jack Conroy



TAOGLAS®

www.taoglas.com

