



FEATURES:

- High Power LED Driver
- Ultra Wide Input Voltage Range
- Remote ON/OFF Function
- SMD Package
- Constant Current Output mode
- High Efficiency (Up to 96%)
- PWM & Analogue Dimming Function
- Operating Temperature range -40°C - +85°C

Models
Single output



Model	Input Voltage (V)	Output Voltage (V)	Maximum Rated Current (mA)	Efficiency Max (%)
AMLDV-4830-NZ	5.5-48	3.3-36	300	96
AMLDV-4835-NZ	5.5-48	3.3-36	350	96
AMLDV-4850-NZ	5.5-48	3.3-36	500	96
AMLDV-4860-NZ	5.5-48	3.3-36	600	96
AMLDV-4870-NZ	5.5-48	3.3-36	700	96

NOTE: All specifications in this datasheet are measured at an ambient temperature of 25°C, humidity<75%, nominal input voltage and at rated output load unless otherwise specified.

Input Specifications

Parameters	Nominal	Typical	Maximum	Units
Voltage range	24	5.5-48		VDC
Absolute Maximum Rating(≤10sec)		5-55		VDC
On/Off Control (Analog Control) (Leave open if not used)	ON: Open or 2.8V > V < 6V			
	OFF: V < 0.6V			
Remote pin current	V=5V		1	mA
Quiescent input current in Shutdown mode	Vin=24V, V<0.6V		400	µA
Dimming Control (Digital Control)	Max PWM Frequency: 200Hz			
Dimming Control (Analog Control) (Leave open if not used)	Input Voltage Range (Vin=5.5-48V)		0-15V	
	Output Current Range(Vin=5.5-48V)		0-100%	
	Control Voltage Range(Full ON)		0.2V±50mV	
	Control Voltage Range(Full OFF)		4.5V±50mV	
	Driving Current(V=5V)		0.6mA(max)	
Input Filter	Capacitor			

Output Specifications

Parameters	Conditions	Typical	Maximum	Units
Current accuracy		±2	±3	%
Input to Output Voltage drop	48V input	3.3-36		VDC
	36V input	3.3-32		
	24V input	3.3-21		
	20V input	3.3-17		
	15V input	3.3-13.2		
	12V input	3.3-10		
	5.5V input	3.3-4		
Short Circuit protection	Continuous, Automatic Recovery			
Efficiency	At full load		96	%
Max load capacitance			1000	µF
Ripple & Noise	20MHz Bandwidth	120		mV p-p
Temperature coefficient	-40 °C to +71 °C	±0.015		%/oC
Output Current Stability	Vin=48V, Vo=3.3~36V		±1	%
Internal Power Dissipation	Vin=24V, 5LEDS		700	mW

General Specifications

Parameters	Conditions	Typical	Maximum	Units
Switching frequency	100% load	370	320-420	KHz
Operating temperature	300mA, 350mA		-40 to +85	°C
	500mA, 600mA, 700mA		-40 to +71	°C
Storage temperature		-55 to +125		°C
Max Case temperature			100	°C
Cooling		Free Air Convection		
Humidity			95	% RH
Case material		Plastic UL94-VO		
Potting material		Epoxy Resin (Flammability UL94V-0)		
Weight		6		g
Dimensions (L x W x H)		0.939 x 0.713 x 0.315 inches	23.86 x 18.10 x 8.00 mm	
MTBF		>2 000 000 hrs (MIL-HDBK-217 F at +25 °C)		

Safety Specifications

Parameters	
Standards	Designed to meet: EN 55022, class B, IEC/EN 61000-4-2 (Perf. Criteria B), IEC/EN 61000-4-3 (Perf. Criteria B), IEC/EN 61000-4-4 (Perf. Criteria B), IEC/EN 61000-4-5 (Perf. Criteria B), IEC/EN 61000-4-5 (Perf. Criteria B)

Pin Out Specifications

Pin	Single	
1	-V Input	DC Supply
7	Remote On/Off PWM Dimming	PWM/ON/OFF or not used
8	-V Output	LED Cathode connection
9	+V Output	LED Anode connection
10	Analogue Dimming	Analogue Dimming or not used
16	+V Input	+ DC Supply

Dimensions

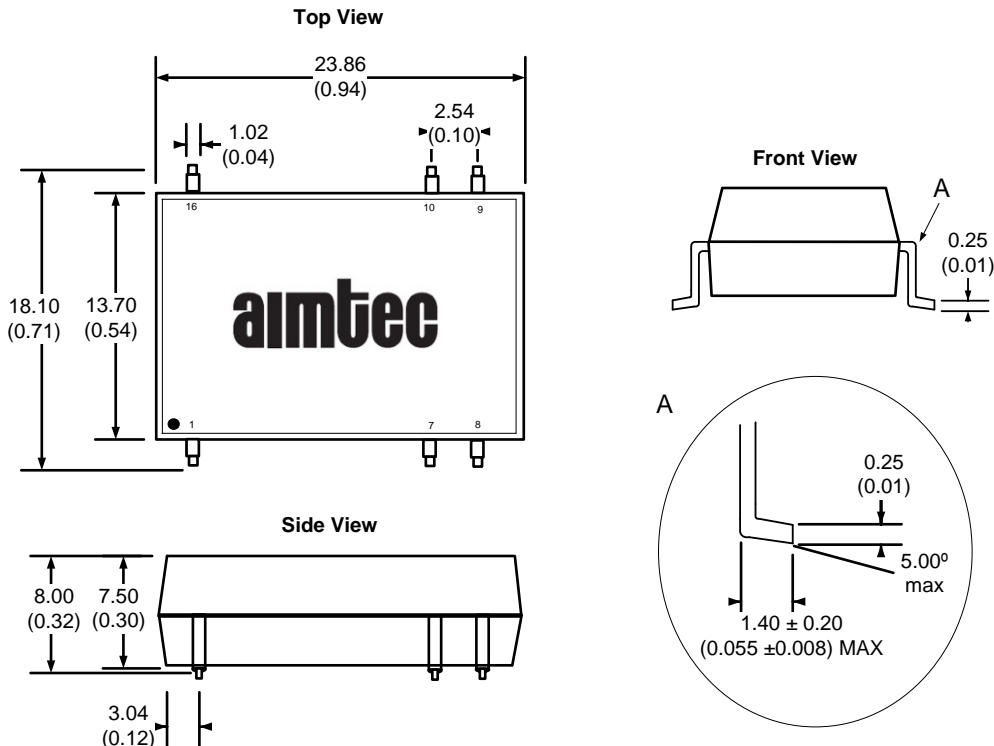

Derating

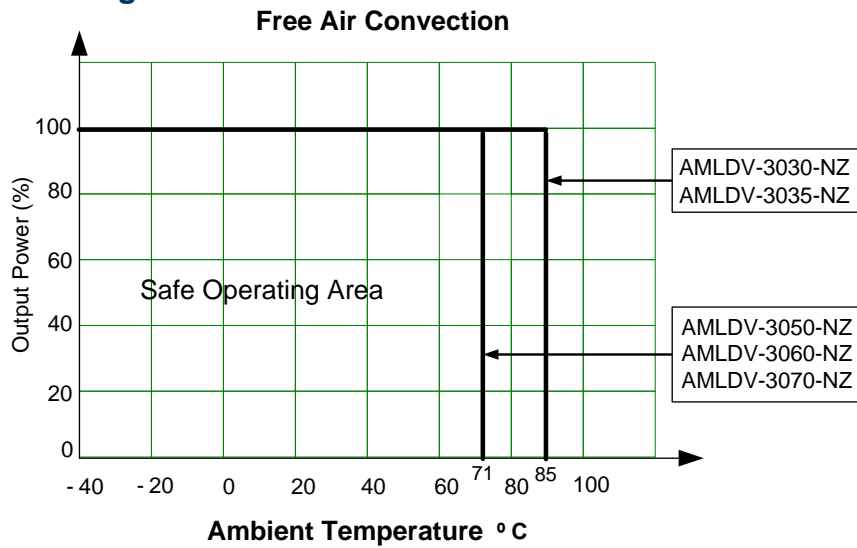

Typical Application Circuits

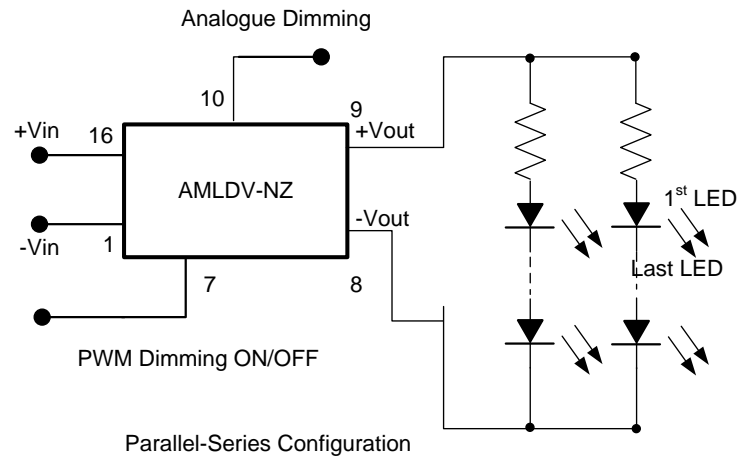
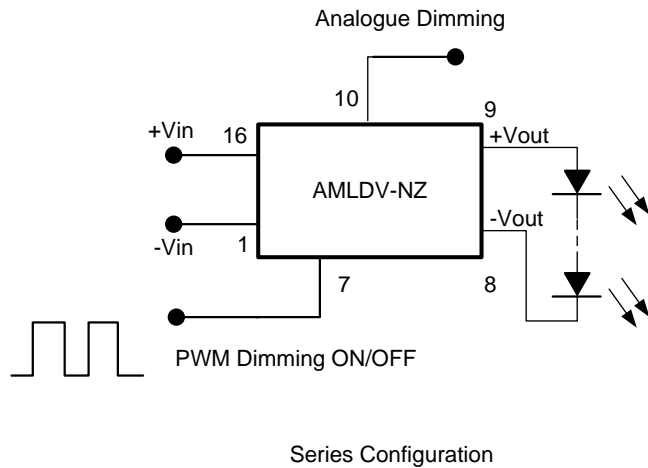

PWM Dimming Control

PWM Digital Control Signal

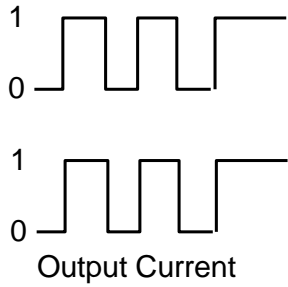

PWM Digital Control Signal

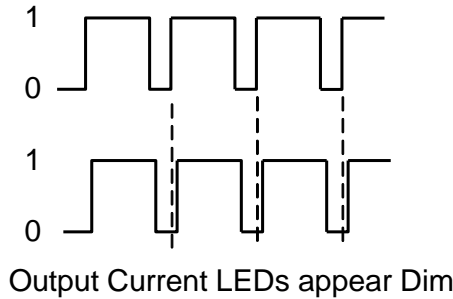

PWM Digital Control Signal

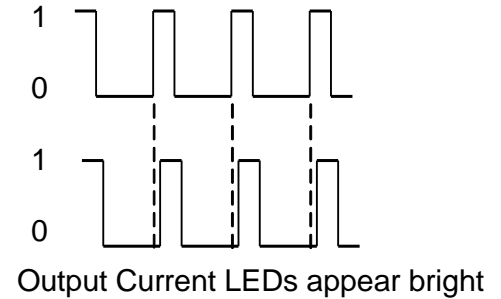

$$I_{out_Set} = \left[\frac{(DT-0.6)}{T} \right] I_{out_Nominal}$$

Where: D is pulse width
T is cycle of the pulse

NOTE: Formula is for reference; actual output current may depend on loading.
The Time On of pulse must be > 0.7mS

Analogue Dimming Control

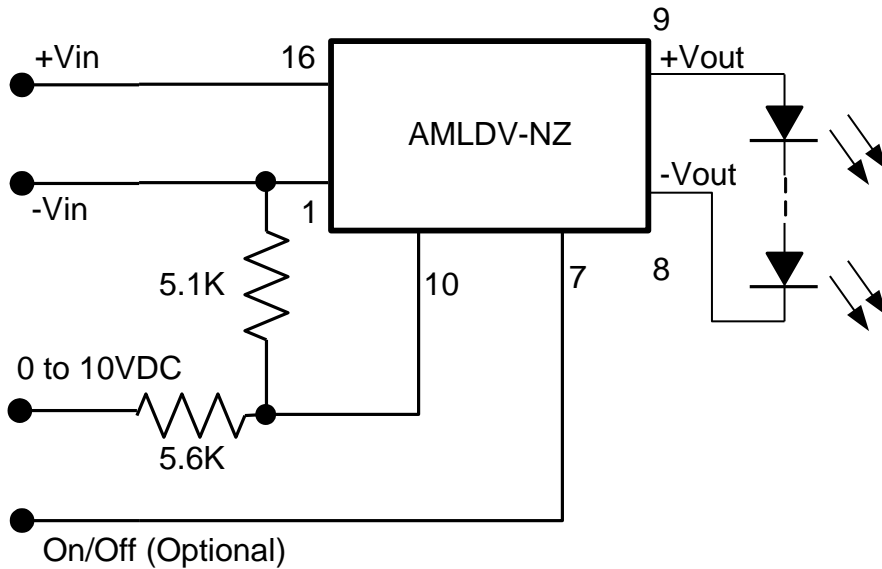

Recommended EMC Circuit

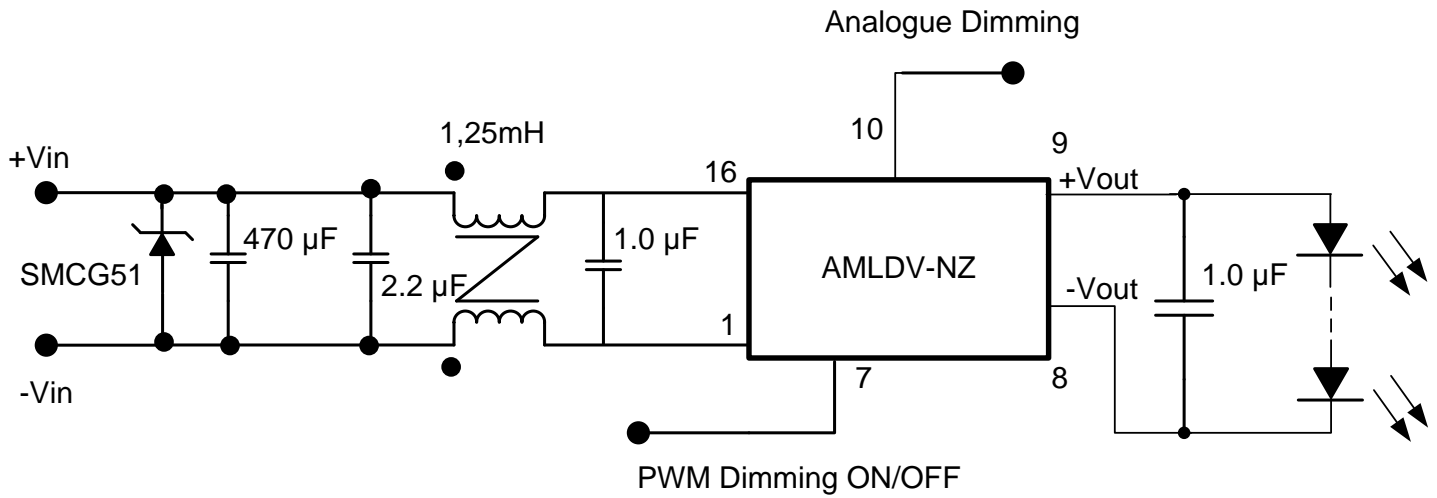

Recommended AC Input Circuit

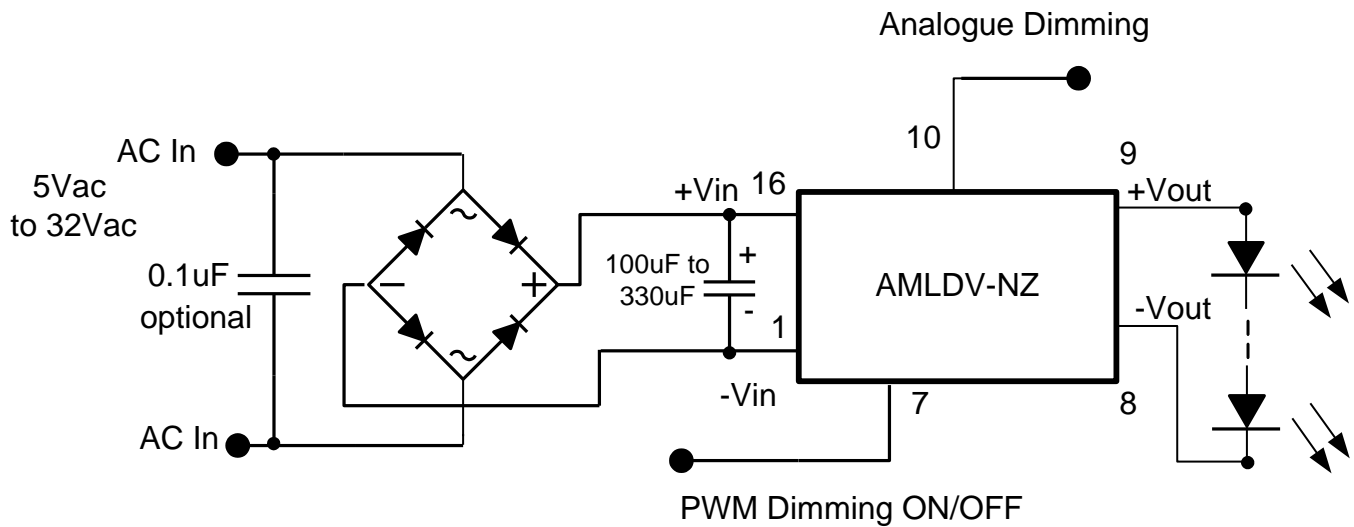

Efficiency versus Input Voltage

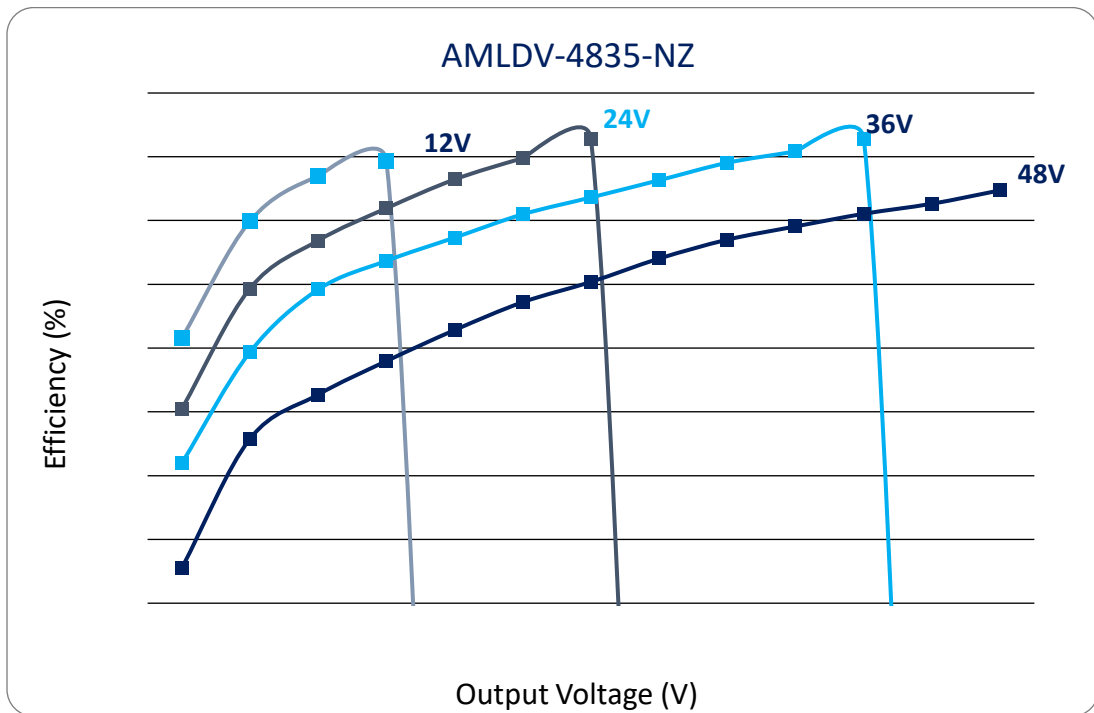
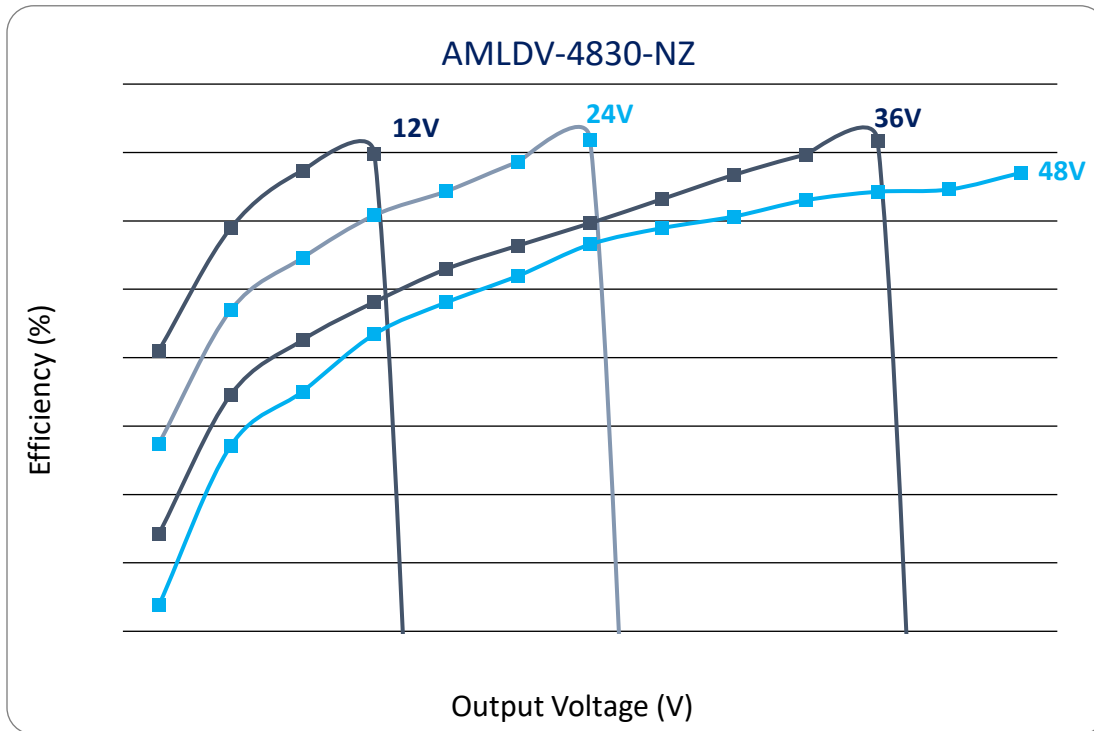

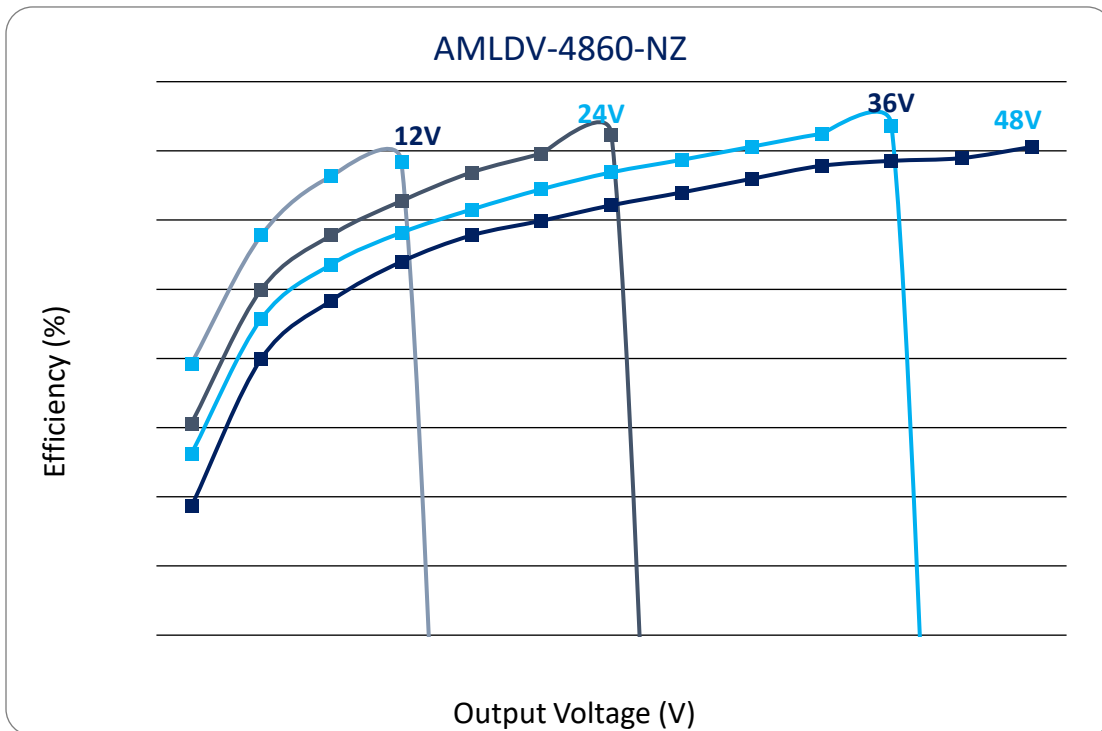
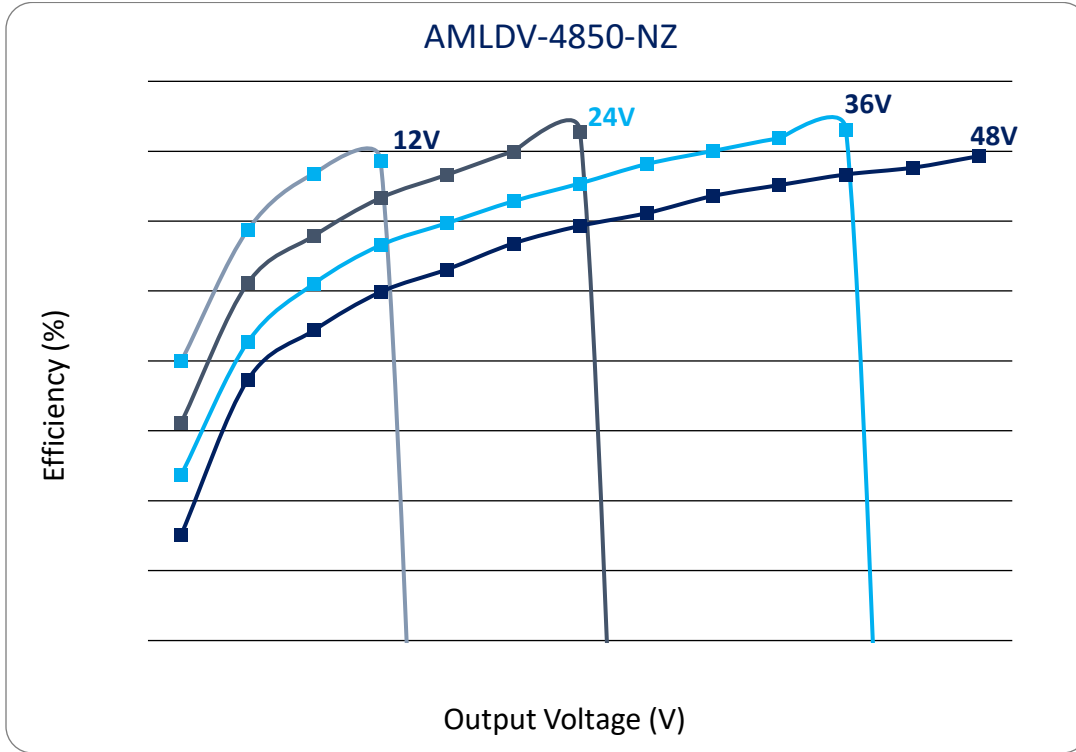

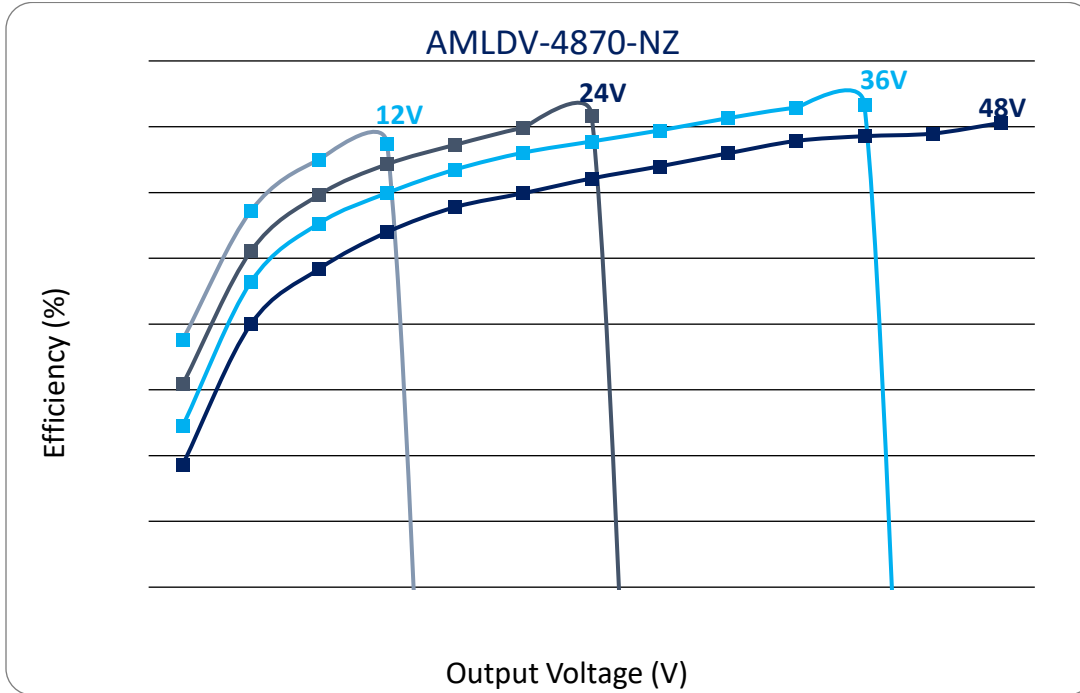

Output Current versus Dimming Voltage

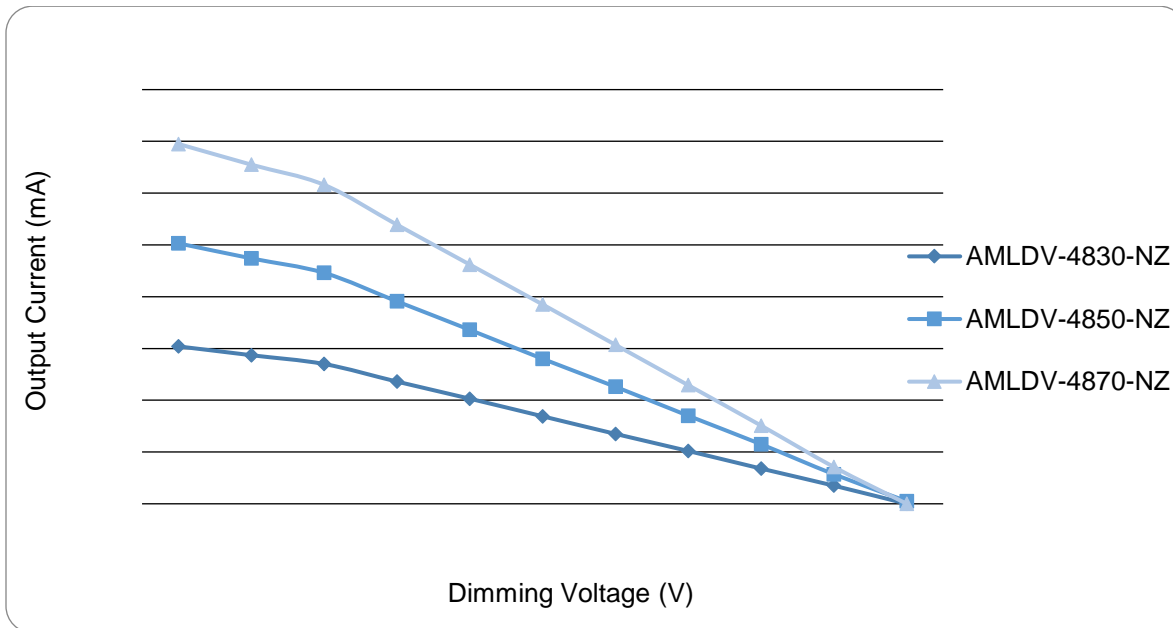

NOTE: 1. Datasheets are updated as needed and as such, specifications are subject to change without notice. Once printed or downloaded, datasheets are no longer controlled by Aimtec; refer to www.aimtec.com for the most current product specifications. 2. Product labels shown, including safety agency certifications on labels, may vary based on the date manufactured. 3. Mechanical drawings and specifications are for reference only. 4. All specifications are measured at an ambient temperature of 25°C, humidity<75%, nominal input voltage and at rated output load unless otherwise specified. 5. Aimtec may not have conducted destructive testing or chemical analysis on all internal components and chemicals at the time of publishing this document. CAS numbers and other limited information are considered proprietary and may not be available for release. 6. This product is not designed for use in critical life support systems, equipment used in hazardous environments, nuclear control systems or other such applications which necessitate specific safety and regulatory standards other the ones listed in this datasheet. 7. Warranty is in accordance with Aimtec's standard Terms of Sale available at www.aimtec.com.