

Fiber Optic GaAlAs LED

OPF32_ , OPF34_ Series

OPF37_ , OPF39_ Series

OPF67_ , OPF69_ Series



Features:

- High radiant output (OPF320, 340, 345, 370, 390, 395)
- Electrically isolated from case (OPF320, 340, 345, 370, 390, 395)
- Component pre-mounted and ready to use (OPF322, 342, 347, 372, 392, 397)
- Pre-tested with fiber to assure performance (OPF322, 342, 347, 372, 392, 397)
- Popular ST style receptacle (OPF322, 342, 347, 372, 392, 397)

Description:

The OPF320 and OPF370 series LED provide fiber optic users with high coupled power and wide bandwidth in an easily connectorized package. The LED's are designed to interface with multimode optical fibers from 50/125 to 200/300 microns.

The OPF322 and OPF372 series LED consist of a hermetic LED, per-mounted and aligned in an ST receptacle. This configuration is designed for PC board or panel mounting. Includes lock washer and jam nut, two 2-56 screws, and a dust cap. The LED's are designed to interface with multimode optical fibers from 50/125 to 200/300 microns.

Part Number Guide

OPF320, OPF322, OPF340, OPF342, OPF370, OPF372, OPF390, OPF392, OPF670

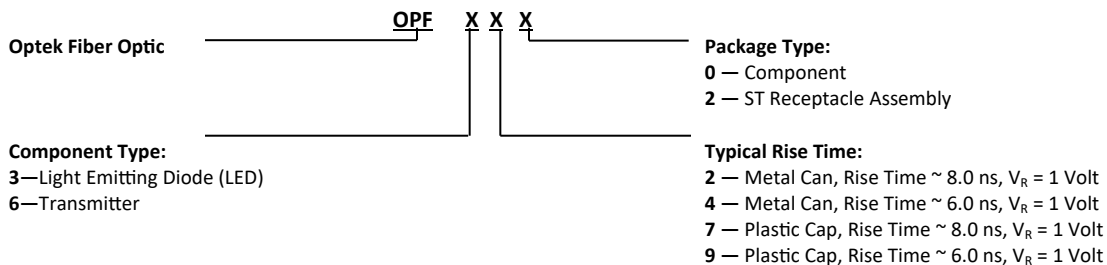

OPF345, OPF347, OPF395, OPF397, OPF672, OPF673, OPF692

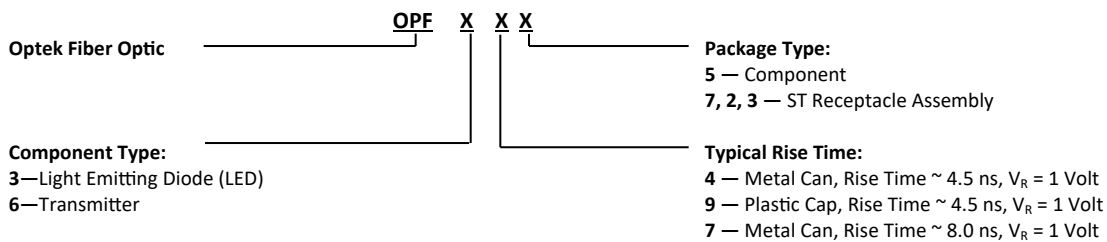

OPF693, OPF694

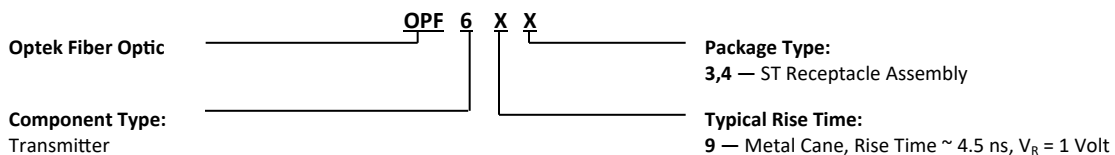

General Note
TT Electronics reserves the right to make changes in product specification without notice or liability. All information is subject to TT Electronics' own data and is considered accurate at time of going to print.

TT Electronics | OPTEK Technology
2900 E. Plano Pkwy, Plano, TX 75074 | Ph: +1 972 323 2200
www.ttelectronics.com | sensors@ttelectronics.com

Fiber Optic GaAIAs LED

OPF32_, OPF34_ Series

OPF37_, OPF39_ Series

OPF67_, OPF69_ Series



Electrical Specifications

Absolute Maximum Ratings ($T_A = 25^\circ\text{C}$ unless otherwise noted)

Storage Temperature Range OPF320, OPF340, OPF342, OPF345, OPF347 OPF322 OPF370, OPF390, OPF395 OPF372, OPF392, OPF396, OPF397, OPF670, OPF672, OPF673, OPF692, OPF693, OPF694	-55°C to +150°C -55°C to +125°C -55°C to +115°C -55°C to +100°C
Operating Temperature Range OPF372, OPF392, OPF396, OPF397, OPF670, OPF672, OPF673, OPF692, OPF693, OPF694 OPF320, OPF340, OPF342, OPF345, OPF347 OPF322, OPF370, OPF390, OPF395	-40°C to +85°C -40°C to +125°C -40°C to +100°C
Reverse Voltage	1.0 V
Continuous Forward Current	100 mA ⁽⁴⁾
Lead Soldering Temperature (1/16 inch (1.6 mm) from case for 5 sec. with soldering iron)	260°C ⁽¹⁾

General Note

TT Electronics reserves the right to make changes in product specification without notice or liability. All information is subject to TT Electronics' own data and is considered accurate at time of going to print.

© TT electronics plc

TT Electronics | OPTEK Technology
2900 E. Plano Pkwy, Plano, TX 75074 | Ph: +1 972 323 2200
www.ttelectronics.com | sensors@ttelectronics.com

Rev E 08/2019 Page 2

Fiber Optic GaAIs LED

OPF32_, OPF34_ Series

OPF37_, OPF39_ Series

OPF67_, OPF69_ Series



Electrical Specifications Cont.

Electrical Characteristics (T_A = 25° C unless otherwise noted)

SYMBOL	PARAMETER	MIN	TYP	MAX	UNITS	TEST CONDITIONS
P _O	Radiant Power Output:					I _F = 100 mA ⁽²⁾ , 50/125 μm cable, N.A.= 0.20
	OPF320C, 322C, 340D, 342D, 345D, 347D, 370D, 372D, 390D, 392D, 395D, 396D, 397D	5	7.5	-	μW	
	OPF320B, 322B, 340C, 342C, 345C, 347C, 370C, 372C, 390C, 392C, 395C, 396C, 397C	10	12.5	-		
	OPF340B, 342B, 345B, 347B, 390B, 392B, 395B, 396B, 397B	15	18	-		
	OPF320A, 322A, 370B, 372B	15	19.0	-		
	OPF340A, 342A, 345A, 347A, 390A, 392A, 395A, 396A, 397A	20	25	-		
OPF370A, 372A	25	29.0	-			
P _O	Total Coupled Power:				dBm	I _F = 100 mA ⁽²⁾ , 50/125 μm cable, N.A.= 0.20
	OPF670-1, 672-1, 673-1	-17.5	-	-15.2		
	OPF670-2, 672-2, 673-2	-16	-	-13		
	OPF692-1, 693-1, 694-1	-19	-	-14		
	OPF692-2, 693-2, 694-2	-16	-	-11		
V _F	Forward Voltage	-	1.8	2.0	V	I _F = 100 mA
λ _p	Peak Output Wavelength	830	850	870	nm	I _F = 50 mA
B	Spectral Bandwidth Between Half Power Points	-	35	-	nm	I _F = 50 mA

Notes:

- (1) RMA flux is recommended. Duration can be extended to 10 sec. max when flow soldering.
- (2) Graded index fiber, 50 μm core, N.A. = 0.20.
- (3) To convert radiant power output to dBm, use the following expression dBm = 10 log (μW/1000).
- (4) Derate linearly 1.0 mA/°C above 25° C.
- (5) Prebias @ 5 mA current.

General Note

TT Electronics reserves the right to make changes in product specification without notice or liability. All information is subject to TT Electronics' own data and is considered accurate at time of going to print.

TT Electronics | OPTEK Technology
 2900 E. Plano Pkwy, Plano, TX 75074 | Ph: +1 972 323 2200
 www.ttelectronics.com | sensors@ttelectronics.com

Fiber Optic GaAIs LED



OPF32_, OPF34_ Series

OPF37_, OPF39_ Series

OPF67_, OPF69_ Series

OPF320, 340, 345

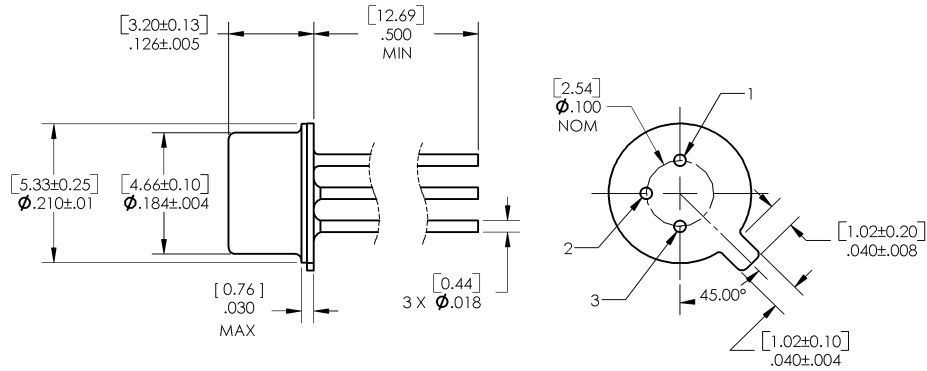

OPF370, 390, 395

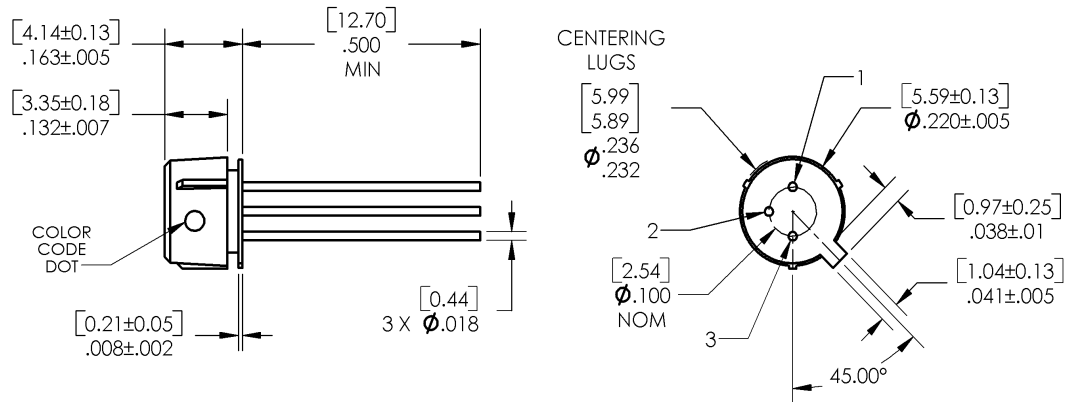

OPF670

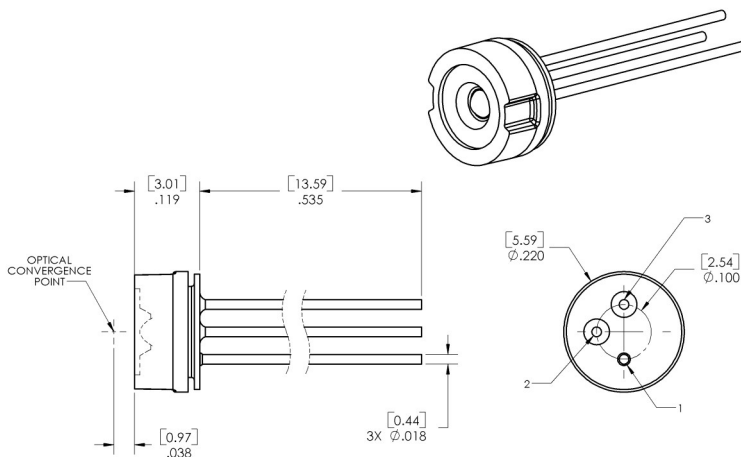

General Note
 TT Electronics reserves the right to make changes in product specification without notice or liability. All information is subject to TT Electronics' own data and is considered accurate at time of going to print.

TT Electronics | OPTEK Technology
 2900 E. Plano Pkwy, Plano, TX 75074 | Ph: +1 972 323 2200
www.ttelectronics.com | sensors@ttelectronics.com

Fiber Optic GaAlAs LED



OPF32_, OPF34_ Series

OPF37_, OPF39_ Series

OPF67_, OPF69_ Series

OPF322, 342, 347, 372, 392, 397, 672

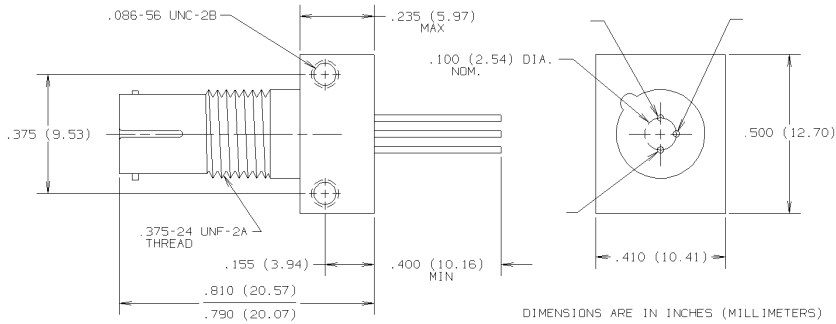

OPF673

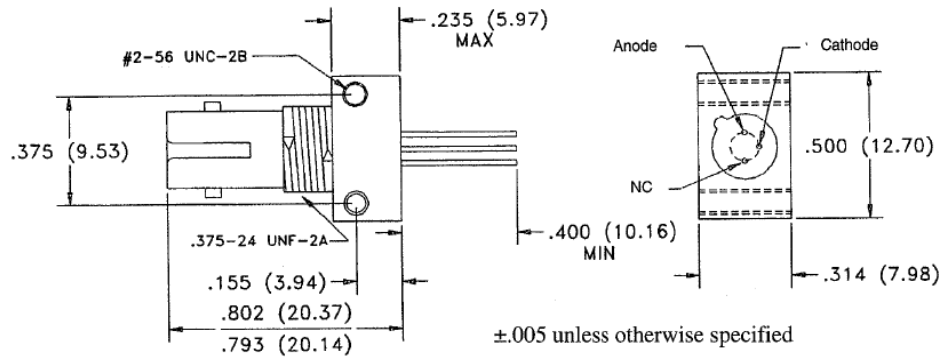

OPF692, 693

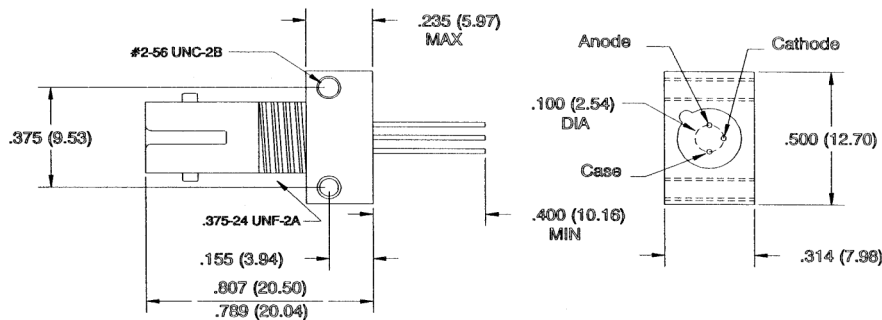

General Note

TT Electronics reserves the right to make changes in product specification without notice or liability. All information is subject to TT Electronics' own data and is considered accurate at time of going to print.

TT Electronics | OPTEK Technology
 2900 E. Plano Pkwy, Plano, TX 75074 | Ph: +1 972 323 2200
 www.ttelectronics.com | sensors@ttelectronics.com

Fiber Optic GaAIAs LED

OPF32_, OPF34_ Series

OPF37_, OPF39_ Series

OPF67_, OPF69_ Series



OPF694

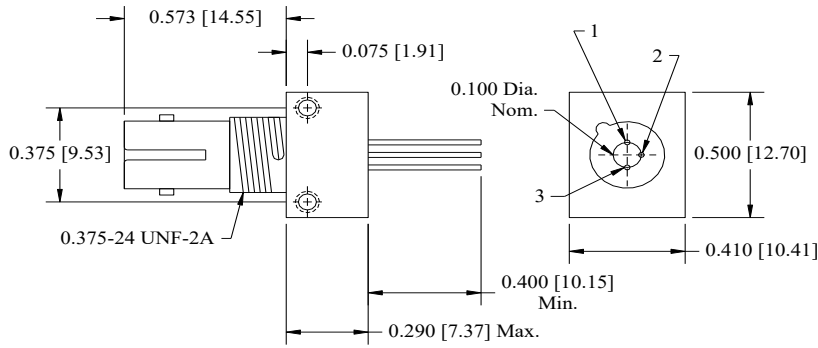

General Note

TT Electronics reserves the right to make changes in product specification without notice or liability. All information is subject to TT Electronics' own data and is considered accurate at time of going to print.

© TT electronics plc

TT Electronics | OPTEK Technology
2900 E. Plano Pkwy, Plano, TX 75074 | Ph: +1 972 323 2200
www.ttelectronics.com | sensors@ttelectronics.com

Rev E 08/2019 Page 6

Fiber Optic GaAIs LED



OPF32_, OPF34_ Series

OPF37_, OPF39_ Series

OPF67_, OPF69_ Series

OPF320, OPF322					
Minimum Coupled Power IF = 100 mA @ 25°C (dBm)					
Fiber	Refractive Index	N.A.	Version-A μW / dBm	Version-B μW / dBm	Version-C μW / dBm
50/125 μm	Graded	0.2	15 / -18.2	10 / -20	5 / -23
62.5/125 μm		0.28	27.2 / -15.7	18.1 / -17.4	9.1 / -20.4
100/140 μm		0.29	78.3 / -11.1	52.2 / -12.8	26.1 / -15.8
200/300 μm	Step	0.41	295.2 / -5.3	196.8 / -7.1	98.4 / -10.1

OPF370, OPF372						
Minimum Coupled Power IF = 100 mA @ 25°C (dBm)						
Fiber	Refractive Index	N.A.	Version-A μW / dBm	Version-B μW / dBm	Version-C μW / dBm	Version-D μW / dBm
50/125 μm	Graded	0.2	25 / -16	15 / -18.2	10 / -20	5 / -23
62.5/125 μm		0.28	45.4 / -13.4	27.2 / -15.7	18.1 / -17.4	9.1 / -20.4
100/140 μm		0.29	130.5 / -8.8	78.3 / -11.1	52.2 / -12.8	26.1 / -15.8
200/300 μm	Step	0.41	492 / -3.1	295.2 / -5.3	196.8 / -7.1	98.4 / -10.1

OPF340, OPF342, OPF345, OPF347, OPF390, OPF392, OPF396, OPF395, OPF397						
Minimum Coupled Power IF = 100 mA @ 25°C (dBm)						
Fiber	Refractive Index	N.A.	Version-A μW / dBm	Version-B μW / dBm	Version-C μW / dBm	Version-D μW / dBm
50/125 μm	Graded	0.2	20 / -17	15 / -18.2	10 / -20	5 / -23
62.5/125 μm		0.28	36.3 / -14.4	27.2 / -15.7	18.1 / -17.4	9.1 / -20.4
100/140 μm		0.29	104.4 / -9.8	78.3 / -11.1	52.2 / -12.8	26.1 / -15.8
200/300 μm	Step	0.41	393.6 / -4	295.2 / -5.3	196.8 / -7.1	98.4 / -10.1

OPF670, OPF672, OPF673				
Minimum Coupled Power IF = 100 mA @ 25°C (dBm)				
Fiber	Refractive Index	N.A.	Version-1 μW / dBm	Version-2 μW / dBm
50/125 μm	Graded	0.2	17.8 / -17.5	25 / -16
62.5/125 μm		0.28	32.3 / -14.9	45.4 / -13.4
100/140 μm		0.29	92.9 / -10.3	130.5 / -8.8
200/300 μm	Step	0.41	350.3 / -4.6	492 / -3.1

OPF692, OPF693, OPF694				
Minimum Coupled Power IF = 100 mA @ 25°C (dBm)				
Fiber	Refractive Index	N.A.	Version-1 μW / dBm	Version-2 μW / dBm
50/125 μm	Graded	0.2	12.6 / -19	25 / -16
62.5/125 μm		0.28	22.9 / -16.4	45.4 / -13.4
100/140 μm		0.29	65.8 / -11.8	130.5 / -8.8
200/300 μm	Step	0.41	248 / -6.1	492 / -3.1

Conversion values in these tables are approximate and will vary depending on many factors.

General Note

TT Electronics reserves the right to make changes in product specification without notice or liability. All information is subject to TT Electronics' own data and is considered accurate at time of going to print.

TT Electronics | OPTEK Technology
2900 E. Plano Pkwy, Plano, TX 75074 | Ph: +1 972 323 2200
www.ttelectronics.com | sensors@ttelectronics.com