

SINGLE IDC CONTACT 18-24 AWG: 9176-500

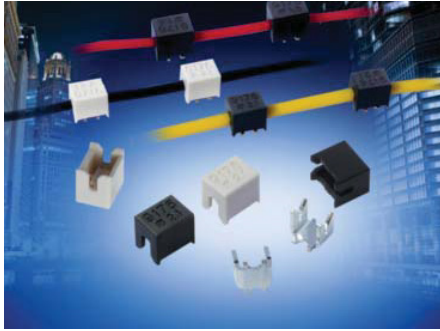

General Information



The 917X series of surface mount Insulation Displacement Connectors (IDC) were developed to meet the harsh automotive and industrial market applications for connecting individual wires directly to a PCB ranging from 14 AWG to 28 AWG. This industry proven contact system has been tested to automotive levels of shock, vibration, and temperature cycling to prove their reliability and robustness. This new single contact was developed as a standalone component to enhance the application uses with the IDC technology. The simplicity of inserting a wire into an SMT contact with a small tool or optional retention / termination cap allows a wide range of devices to be connected to the PCB without soldering. In SSL applications specifically, these contacts are used to bring power and signal onto the PCB or are used to daisy chain multiple boards together in a long string. While the IDC contact provides a gas-tight connection to conductor of the wire, the optional cap provides a positive strain relief even in the harshest conditions. In case of repair, the wires can be removed and replace up to three times.

The single 9176 series contact and cap accepts 18 AWG to 24 AWG wires with an insulation diameter ranging from 1.1mm to 2.1mm. These dual beam contacts support a 10 amp current rating with a large SMT solder base to provide maximum stability on the PCB. The optional locking strain relief cap acts as the termination tool for severe vibration applications.

APPLICATIONS

- Connecting discrete wire components directly to the PCB
- Bringing power and signals onto a PCB
- Daisy chaining PCB's together to create a continuous string of boards
- Application notes: refer to 201-01-124

FEATURES AND BENEFITS

- IDC contact is supplied in T&R pockets for standard SMT placement
- IDC contact provides a gas-tight connection to the PCB for long term reliability
- Optional termination cap provides additional strain relief for severe environments
- Tested to automotive levels on shock, vibration and temperature cycling for reliability
- Reduced total applied cost versus solder or crimp processes
- Individual contacts can be located anywhere on the PCB based on specific application

ELECTRICAL

- Current Rating: 10 Amps/Contact
- Voltage Rating: Dependant on component proximity

ENVIRONMENTAL

- Operating Temperature: -40°C to +125°C

MECHANICAL

- Insulator Material: Nylon 46: UL94V0
- Contact Material: Phosphor Bronze
- Plating: Tin over Nickel
- Durability: 3 Cycles

HOW TO ORDER – CONTACT OPTIONS

70
Prefix
70 = Contact

9176
Series

001
Number of Ways

Code	No of Ways	Details
001	1	Page 39

4XX
Wire Gauge Size

Code	Accepted Wire Gauge
501	18 Gauge Stranded
511	20 Gauge Solid or Stranded
522	22 Gauge Solid or Stranded
532	24 Gauge Solid or Stranded

006
Plating Option
006 = Pure Tin all over

HOW TO ORDER – CAP OPTIONS

60
Prefix
60 = Cap

9176
Series

001
Number of Ways

Code	No of Ways	Details
001	1	Page 43

5XX
Wire Gauge Size

Code	Wire Insulation (AWG)
516	1.1-1.6 (22-24)
521	1.6-2.1 (18-20)

X00
Insulator Color

Code	Color	Application
000	Black	Industrial
100	White	Lighting



CONNECTOR/TOOLING PART NUMBER MATRIX

SERIES 9176-500 IDC				HAND INSERTION TOOLING*		ACCESSORY CAPS		
AWG	Wire Insulation	Positions	Part Number	Plastic (medium volume)	Metal (high volume)	Cap Application Tool	White	Black
18	Ø 1.6 - 2.1	1p	709176001501006	069176702001000	069176701901000	069176701801000	609176001521100	609176001521000
20	Ø 1.6 - 2.1	1p	709176001511006	069176702001000	069176701901000	069176701801000	609176001521100	609176001521000
22	Ø 1.1 - 1.6	1p	709176001522006	069176702002000	069176701902000	069176701801000	609176001516100	609176001516000
24	Ø 1.1 - 1.6	1p	709176001532006	069176702002000	069176701902000	069176701801000	609176001516100	609176001516000

* Hand Insertion Tooling and Cap Application - Universal Hand Tool 067000773001000; Consult Application Notes 201-01-124

Certification: UL File #E90723



The Important Information/Disclaimer is incorporated in the catalog where these specifications came from or available online at www.avx.com/disclaimer/ by reference and should be reviewed in full before placing any order.

090721

SINGLE IDC CONTACT 18-24 AWG: 9176-500

Contact Details

CONTACT DETAILS

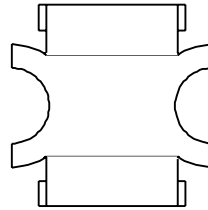
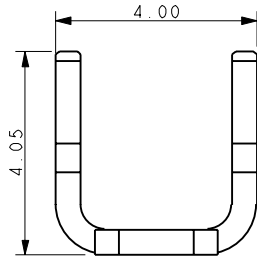
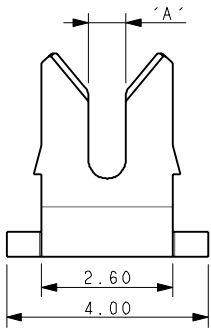

Code	Accepted Wire Gauge	A
501	18 AWG Stranded	0.74
511	20 AWG Solid and Stranded	0.60
522	22 AWG Solid and Stranded	0.47
532	24 AWG Solid and Stranded	0.37

NOTES:

- CONNECTOR FOR IDC WIRE TO BOARD CONNECTION.
- CONTACT MATERIAL: PHOSPHOR BRONZE.
- CONTACT PLATING: PURE TIN.
- CONNECTOR DESIGNED TO ACCEPT BETWEEN 20AWG AND 24AWG SOLID AND STRANDED WIRES, 18AWG WILL ONLY ACCEPT STRANDED WIRES, SEE TABLE.
- ALL DIMENSIONS ± 0.20 UNLESS TOLERANCED
- FOR FULL PRODUCT SPECIFICATION REFER TO ELCO SPEC 201-01-126 AND APPLICATION NOTES 201-01-124.
- SMT PCB LAYOUT, REFER TO SHEET 3.
- PACKING IN TAPE AND REEL, QUANTITY 1000 PER REEL.
- WHEN REQUIRED, MATCHING CAP DETAILS ON DRAWING 60-9176-001-5XX-X00S
- ASSEMBLY TOOLING ON SHEETS 4 (WITH CAP) AND 5 (WITHOUT CAP).

AREA AVAILABLE FOR PICK & PLACE 2.00mm SQUARE

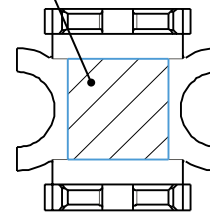

PACKING DETAILS

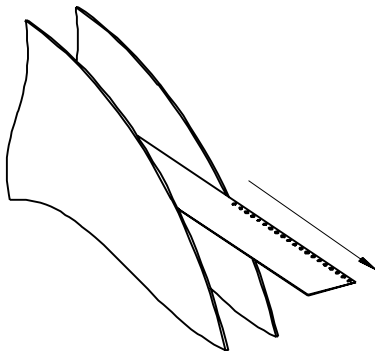

REEL QTY	1000
LEADER	480mm
TRAILER	120mm

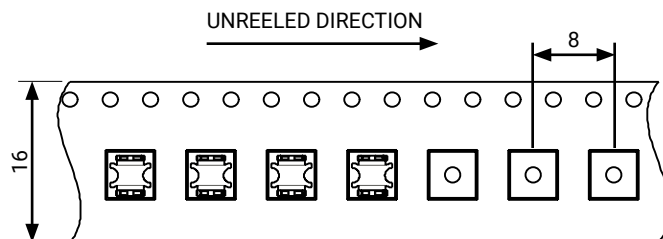

SINGLE IDC CONTACT 18-24 AWG: 9176-500

PBC Layout

18-24 AWG IDC WIRE TO BOARD CONNECTOR SINGLE CONTACT

SMT PCB LAYOUT PURE TIN PADS

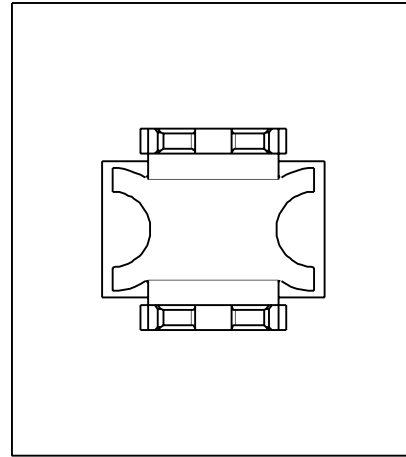
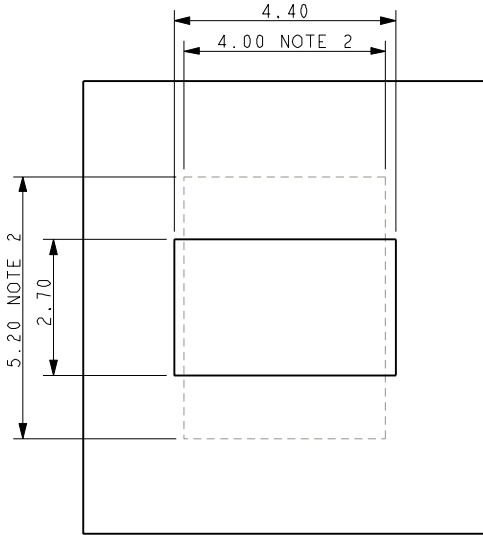

ORIENTATION OF CONTACT ON PAD

ASSEMBLED/INSTALLED PRODUCTS

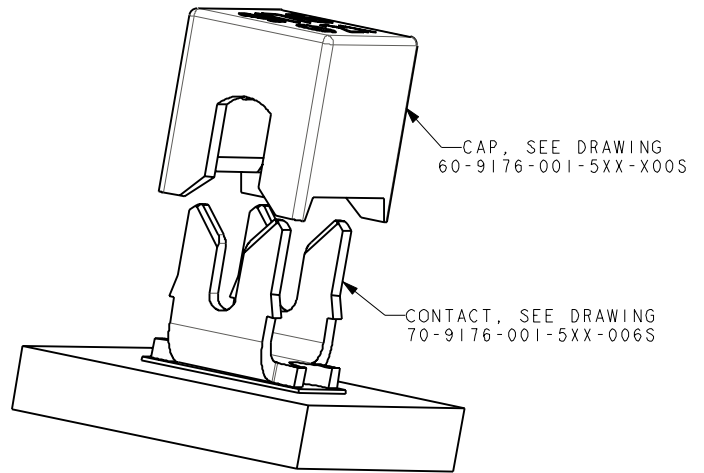
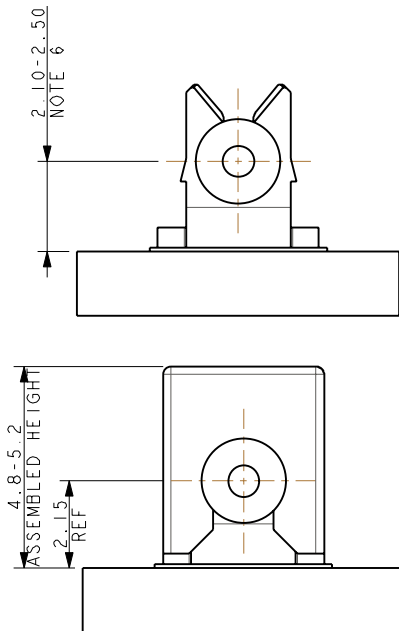

NOTES:

1. CONNECTOR CAN BE USED WITH CONTACT ONLY OR WITH OPTIONAL CAP.
2. OUTLINE OF CAP WHEN USED.
3. FOR FULL PRODUCT SPECIFICATION REFER TO ELCO SPEC 201-01-126 AND 201-01-124.
4. ALL DIMENSIONS ± 0.20 UNLESS TOLERANCED.
5. ASSEMBLY TOOLING ON SHEETS 4 (WITH CAP) AND 5 (WITHOUT CAP).
6. WIRE CENTRE LINE HEIGHT ABOVE THE PCB, THIS INCLUDES AN ALLOWANCE OF 0.10MM FOR SOLDER AND

SINGLE IDC CONTACT 18-24 AWG: 9176-500

Assembly Tooling

ASSEMBLY TOOLING – CAP USED

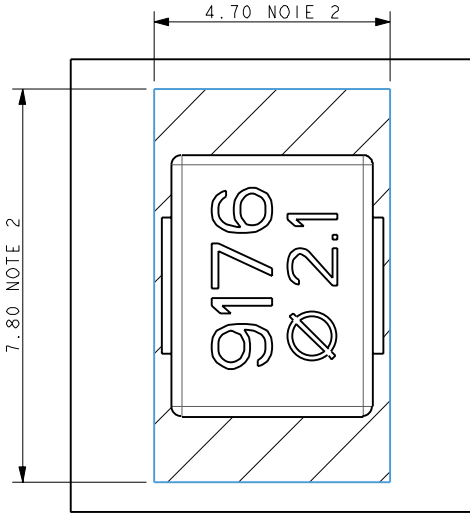

NOTES:

1. ASSEMBLY TOOLING FOR CAP.
2. AREA OF PCB TO BE KEPT CLEAR OF COMPONENTS, TACKS PERMISSIBLE.
3. WIRE AND CAP INSERTED IN ONE OPERATION.
4. REFER TO APPLICATION NOTE 201-01-124 FOR FURTHER INFORMATION.
5. REFER BELOW WHEN CONTACT USED WITHOUT CAP.

06-9176-7018-01-000
CAP APPLICATION TOOL
PLASTIC

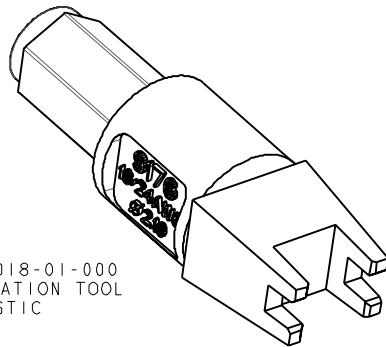

06-9176-7025-01-000
CAP APPLICATION TOOL
METAL

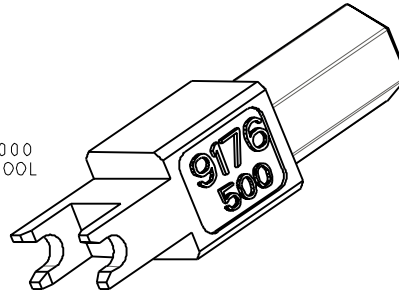

ORIENTATE CAP IN TOO

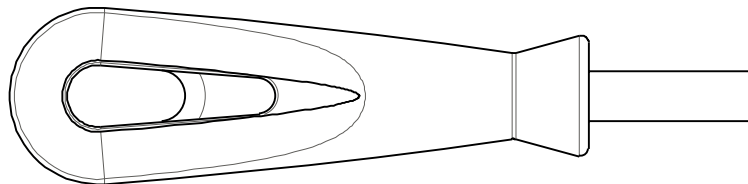

06-7000-7730-01-000
UNIVERSAL HANDLE

SINGLE IDC CONTACT 18-24 AWG: 9176-500

Assembly Tooling

ASSEMBLY TOOLING – CAP NOT USED WIRE ONTO CONTACT

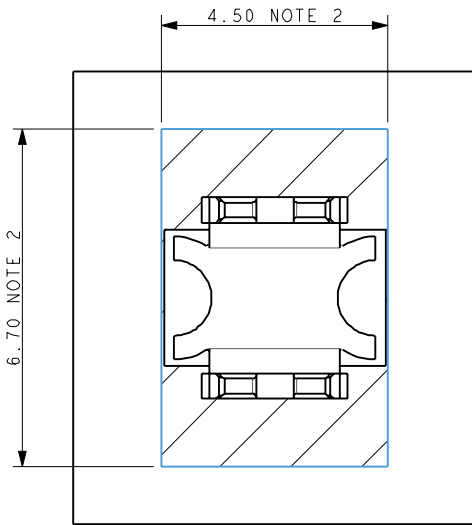

NOTES:

1. ASSEMBLY TOOLING FOR CONTACT ONLY, NO CAP USED.
2. MINIMUM AREA OF PCB TO BE KEPT CLEAR OF COMPONENTS, TRACKS PERMISSIBLE.
3. REFER TO TABLE FOR CORRECT TOOL/WIRE COMBINATION.
4. REFER TO APPLICATION NOTE 201-01-124 FOR FURTHER INFORMATION

WIRE INSULATION Ø	METAL TOOL HIGH VOLUME	PLASTIC TOOL SMALL TO MEDIUM VOLUME	HANDLE
1.10 to 1.60	06-9176-7019-02-000	06-9176-7020-02-000	06-7000-7730-01-000
1.60 to 2.10	06-9176-7019-01-000	06-9176-7020-01-000	06-7000-7730-01-000

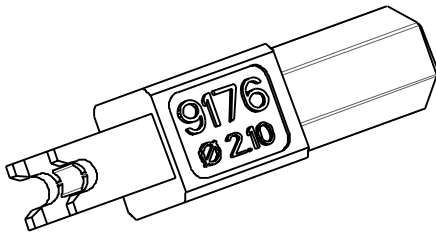

06-9176-7019-01-000
06-9176-7020-01-000
2.1Ø WIRE

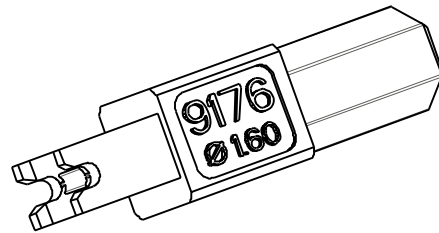

06-9176-7019-02-000
06-9176-7020-02-000
1.6Ø WIRE

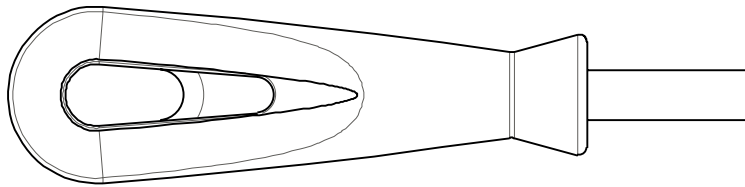

06-7000-7730-01-000
UNIVERSAL HANDLE

SINGLE IDC CONTACT 18-24 AWG: 9176-500

Cap Details

CAP DETAILS

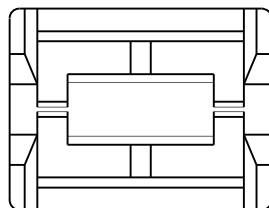
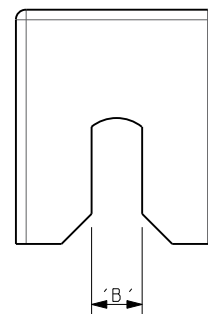
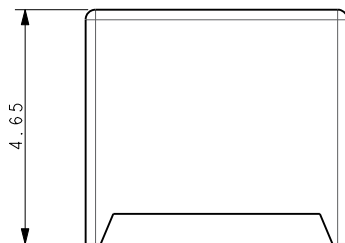
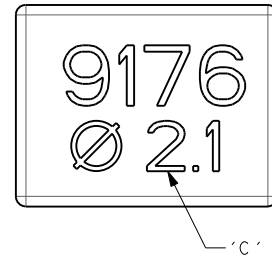
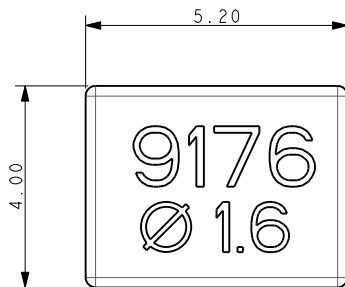

Code	Insulator Diameter (AWG)	B	Text C
516	1.1 to 1.6 (22-24)	1.00	Ø 1.6
521	1.6 to 2.1 (18-20)	1.50	Ø 2.1

NOTES:

1. CAP FOR IDC WIRE TO BOARD CONNECTION.
2. CAP MATERIAL: GLASS FILLED NYLON 46, COLOR SEE PAGE 41.
3. CAPS DESIGNED TO ACCOMMODATE WIRE INSULATION DIAMETERS 1.1MM TO 2.1MM.
4. ALL DIMENSIONS FOR REFERENCE UNLESS OTHERWISE STATED.
5. FOR FULL PRODUCT SPECIFICATION REFER TO ELCO SPEC 201-01-106, APPLICATION NOTES 201-01-124.
6. PACKING IN BAGS, QUANTITY 1000 PER BAG.
7. FOR INSTALLATION DETAILS REFER TO DRAWING 70-9176-001-XX-006S.