

REVISIONS				
P.	LTN	DESCRIPTION	DATE	APPROV
1		PRELIMINARY	14JAN2019	IT SH
2		ADD MIN FOR BEZEL PITCH	06AUG2019	IT SH
3		ADD NEW DASH NUMBER -2	24FEB2021	SZ SZ

- 1 MATERIAL:
 CAGE ASSEMBLY: STAINLESS STEEL, 0.25MM THICK
 EMI SPRINGS: PHOSPHOR BRONZE, NICKEL PLATED
 PCB GASKET: RF ABSORBER
- 2 MINMUM PC BOARD THICKNESS:
 SINGLE SIDED: 1.45MM
 BELLY TO BELLY: 2.25MM
- 3 PADS AND VIAS CHASSIS GROUND
- 4 DATUM AND BASIC DIMENSION ESTABLISHED BY CUSTOMER
- 5. MATES WITH SFP MSA COMPLIANT TRANSCEIVERS
- 6. INTERPRETATION OF DATUM REFERENCE FRAME IN ACCORDANCE WITH SECT 4.4.1.1 OF ASME Y14.5M-1994
- 7 REFERENCE APPLICATION SPEC. 114-13120, HOLE A, FOR RECOMMENDED DRILL HOLE DIAMETER AND PLATING THICKNESS
- 8 REFERENCE APPLICATION SPEC. 114-13120, HOLE B, FOR RECOMMENDED DRILL HOLE DIAMETER AND PLATING THICKNESS
- 9 HOLE PATTERN REPEATS FOR EACH PORT, SPACING BETWEEN PORTS IS 14.25mm
- 10. PRODUCT COMPLIES WITH SPECIFICATION SFF-8433, IMPROVED PLUGGABLE FORMFACTOR FOR SFP+ GANGED CAGES
- 11 CONTACT STANDOFF WILL PIERCE GASKET WHEN PROPERLY PRESSED INTO PCB.
- 12 PART NUMBER WITH HEATSINK OPENING.

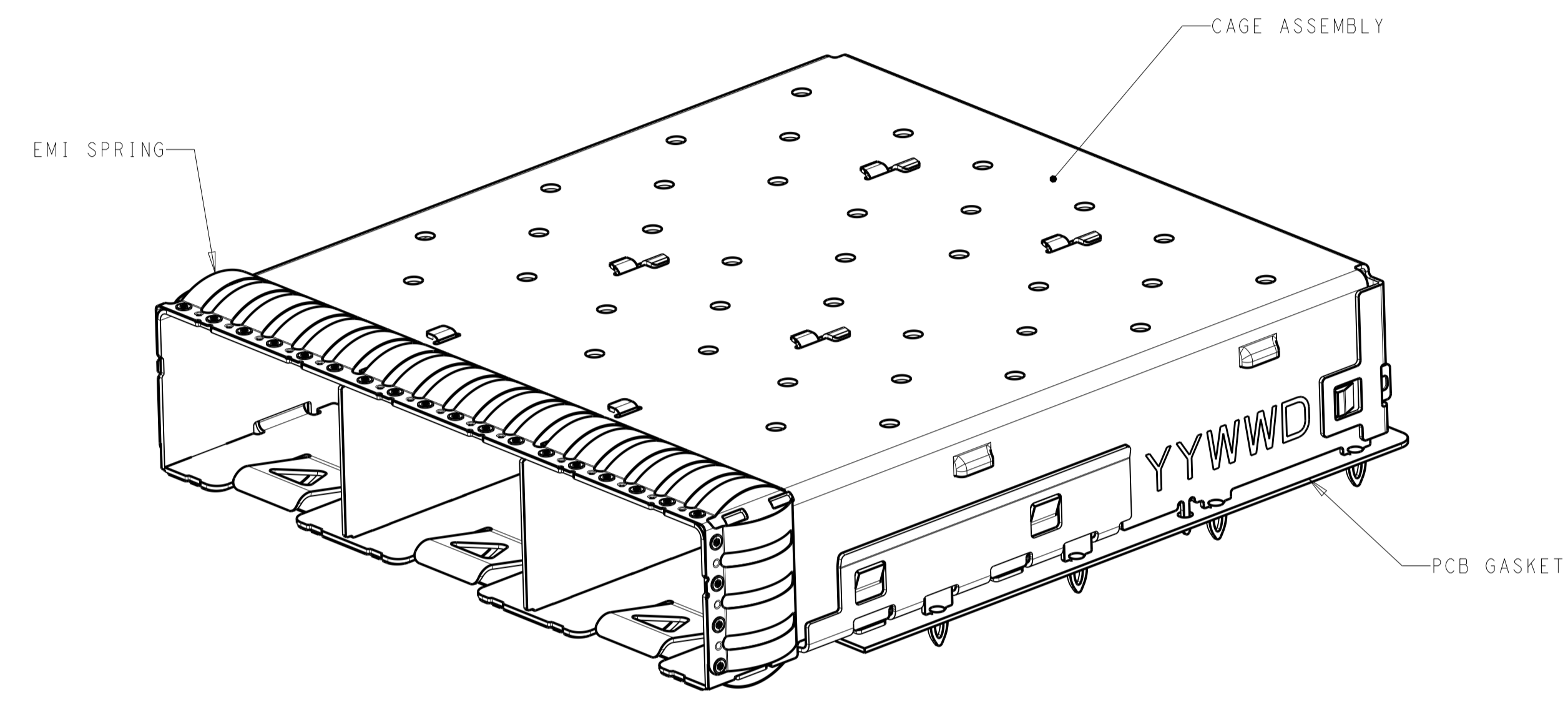

2349050-1 AS SHOWN

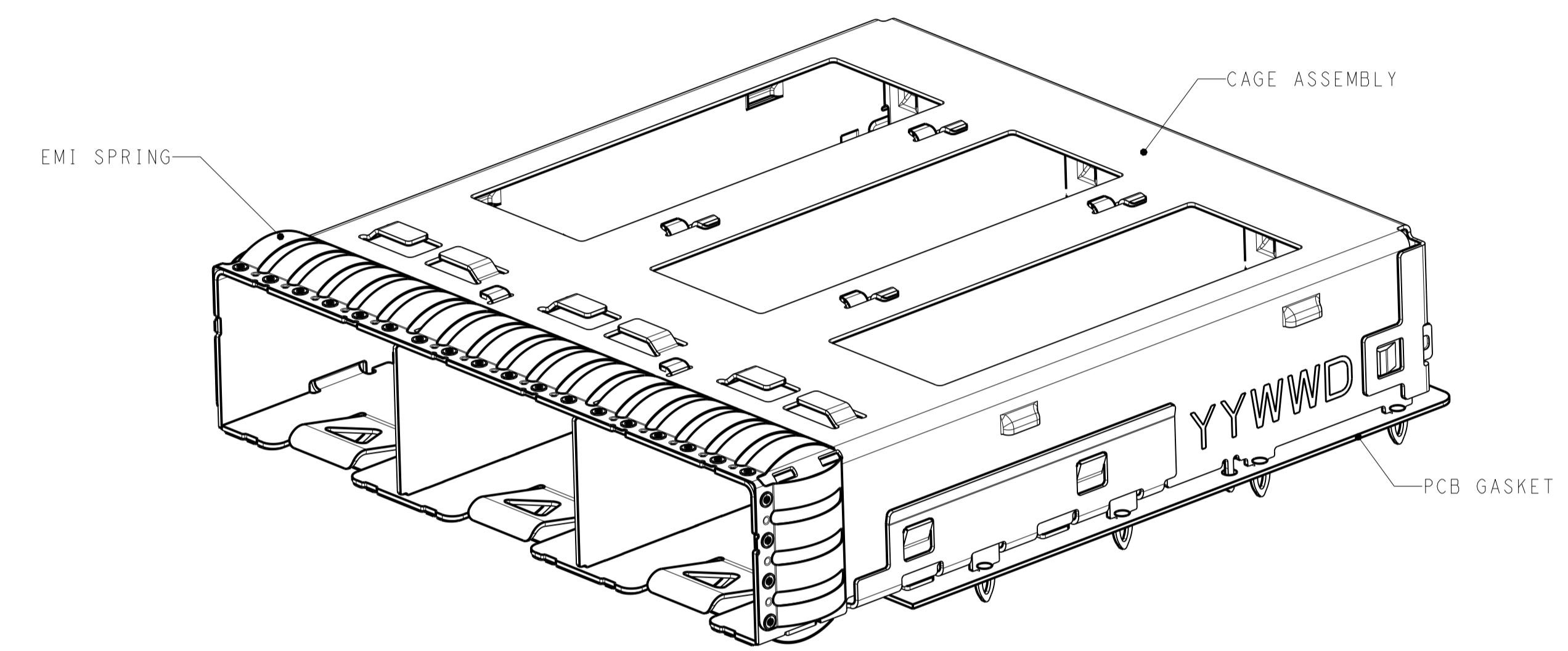

2349050-2 AS SHOWN

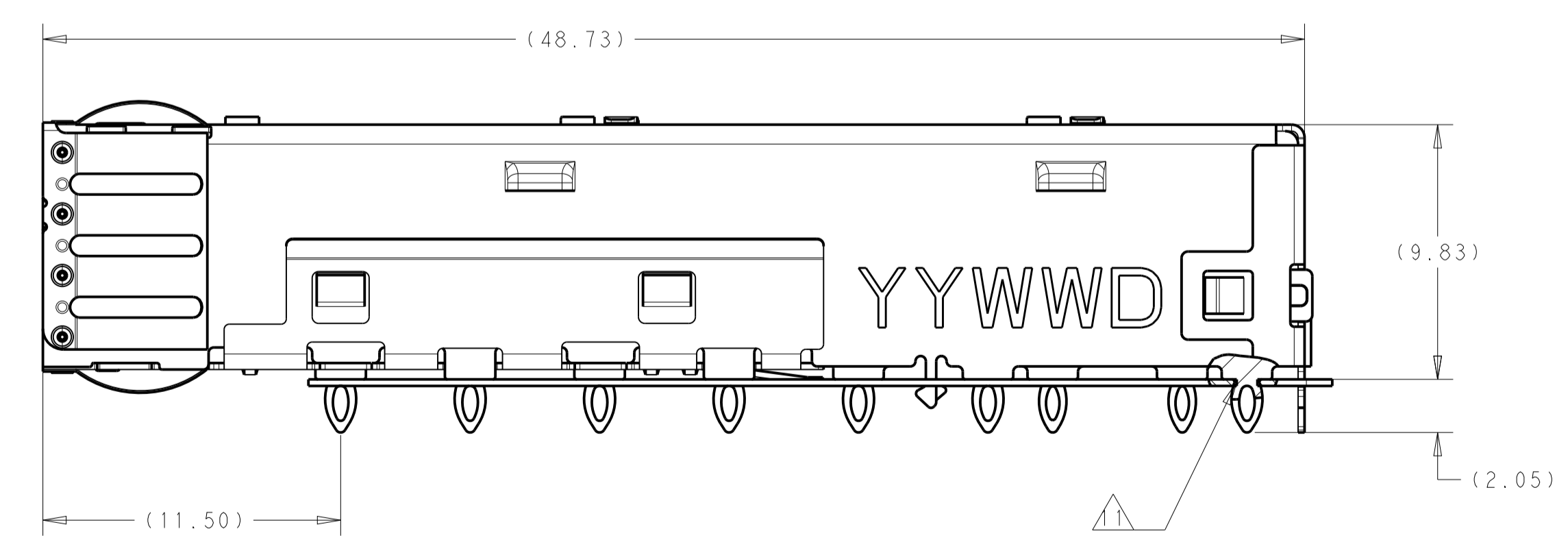
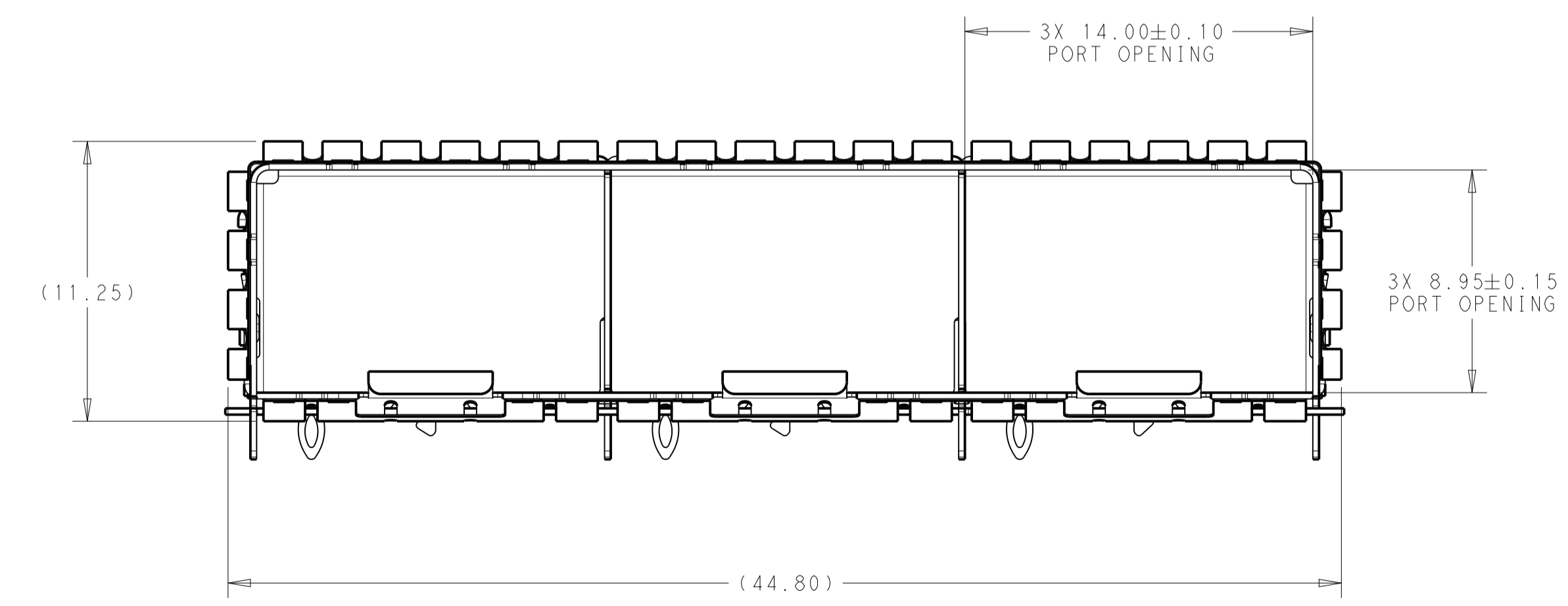

1	2349050-2
1	2349050-1
MATERIAL	PART NUMBER

THIS DRAWING IS A CONTROLLED DOCUMENT.		OWN: IVAN TIAN 14JAN2019	TE Connectivity
DIMENSIONS: mm		CHK: SEAN HAN 14JAN2019	
TOLERANCES UNLESS OTHERWISE SPECIFIED:		APP'D: SEAN HAN 14JAN2019	
0 PLC ± 1 PLC ±0.25 2 PLC ±0.15 3 PLC ± 4 PLC ± ANGLES ±1°		NAME: 1X3 ZSFP+ CAGE ASSEMBLY PRODUCT SPEC: 108-2364 APPLICATION SPEC: 114-13120 WEIGHT: - CUSTOMER DRAWING	
MATERIAL:		FINISH: -	SIZE: A1 CAGE CODE: 07799 DRAWING NO: 2349050 SCALE: 2:1 SHEET 1 OF 4 REV 3

REVISIONS				
REV	DATE	DESCRIPTION	BY	APP'D
-	-	SEE SHEET 1	-	-

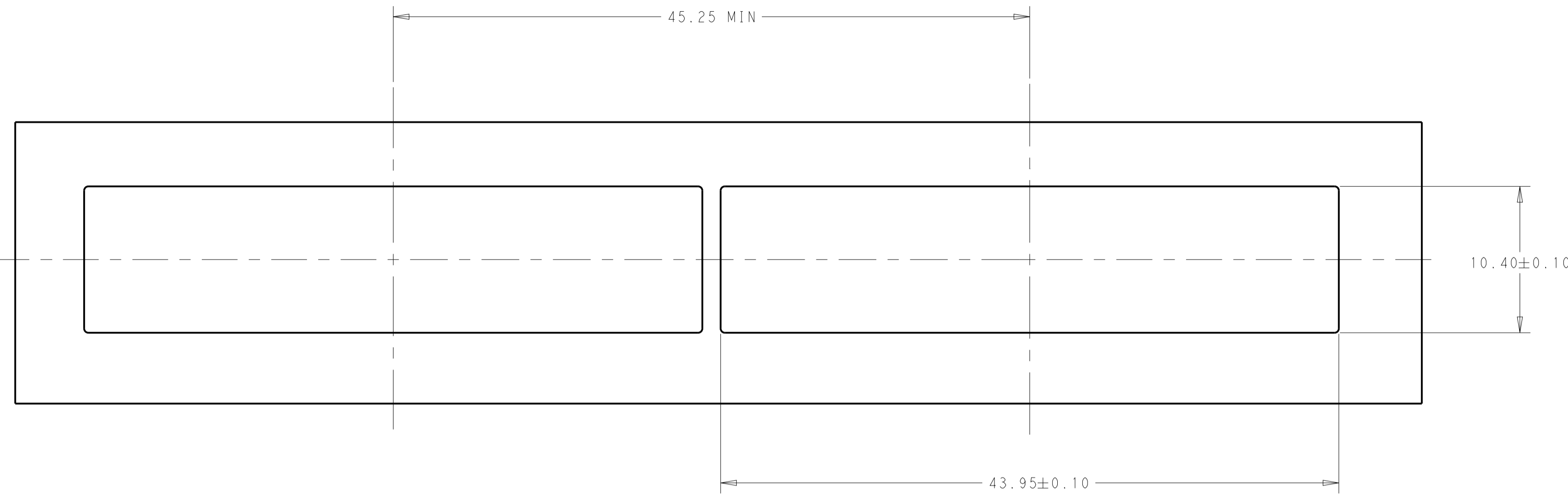

RECOMMENDED BEZEL CUT-OUT
 SINGLE SIDED APPLICATION
 SCALE 4:1

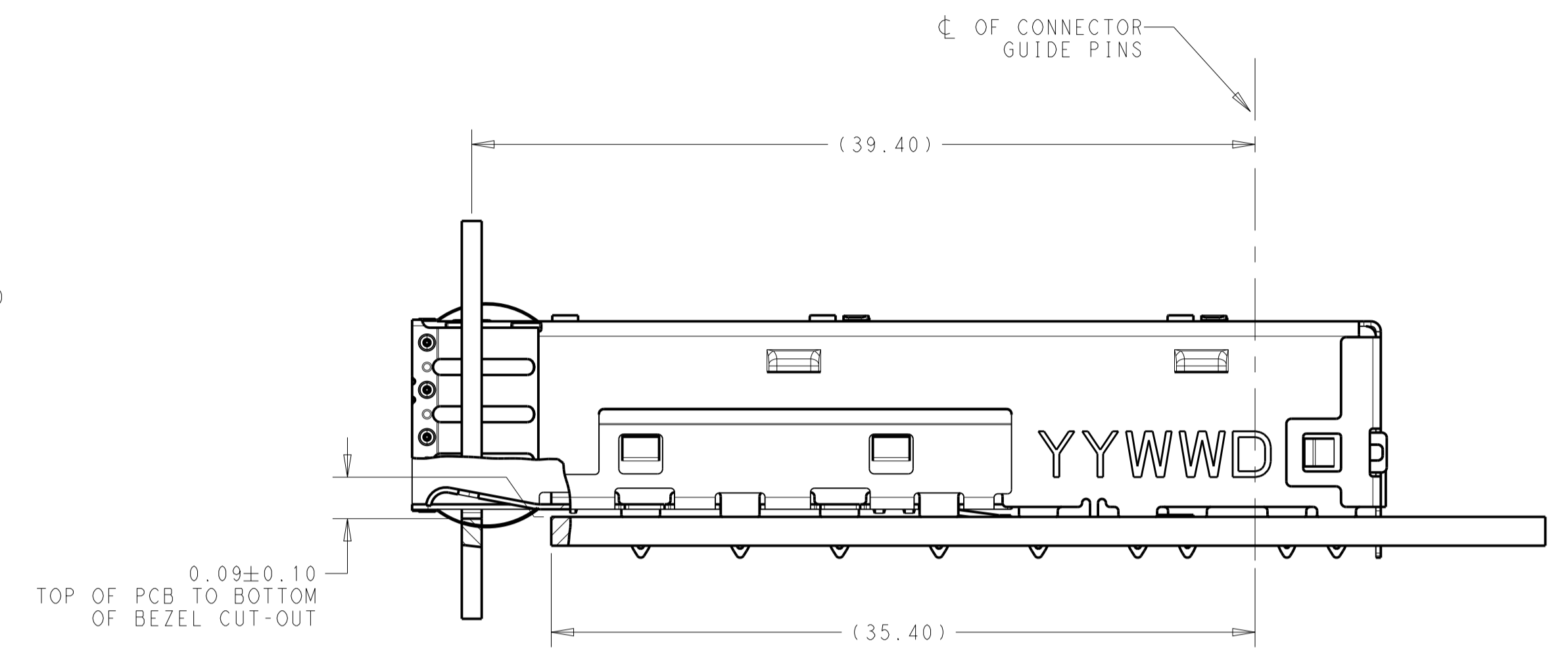

MOUNTED ON PC BOARD
 SHOWN THRU RECOMMENDED BEZEL
 SCALE 4:1

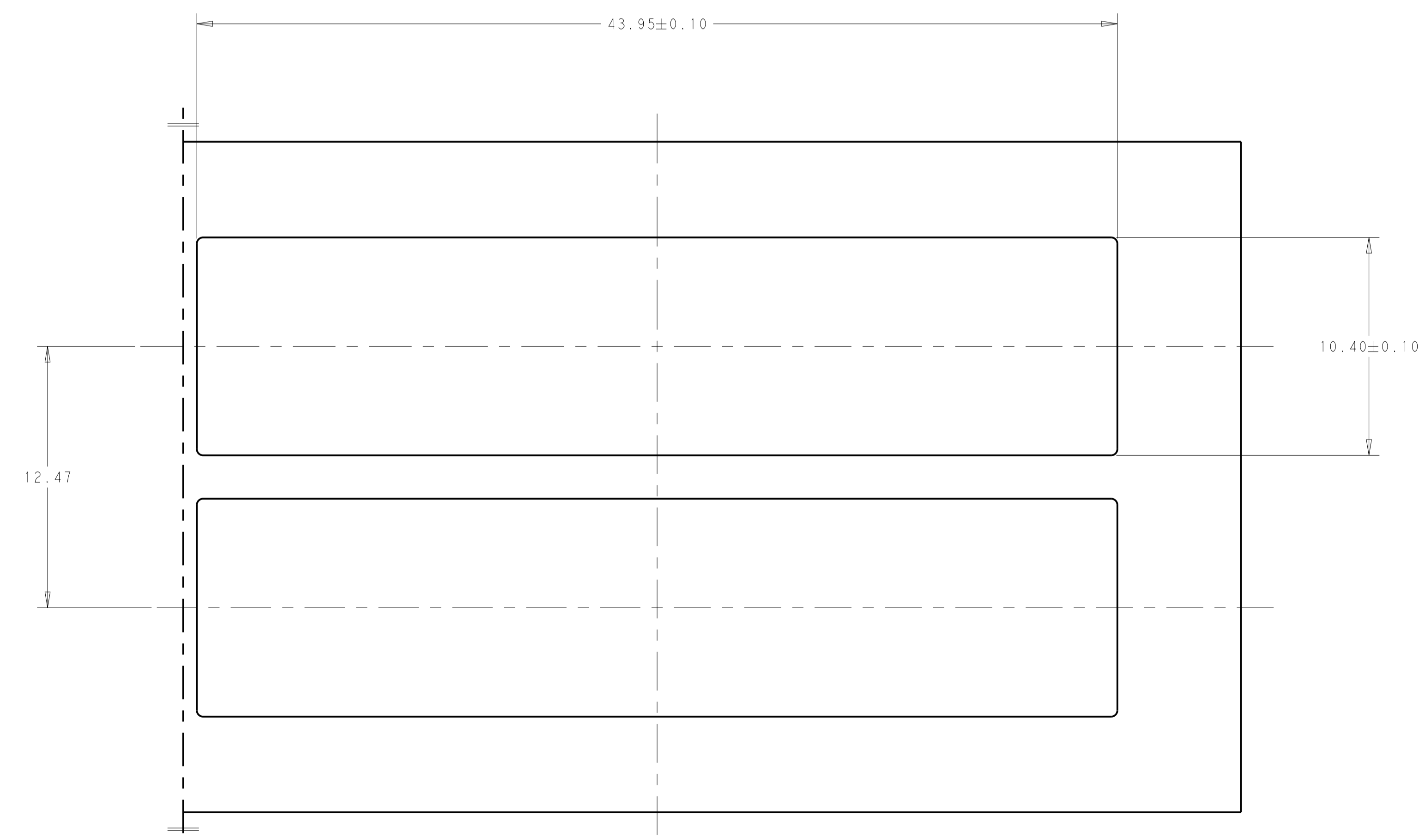

RECOMMENDED BEZEL CUT-OUT
 BELLY TO BELLY APPLICATION
 SCALE 6:1

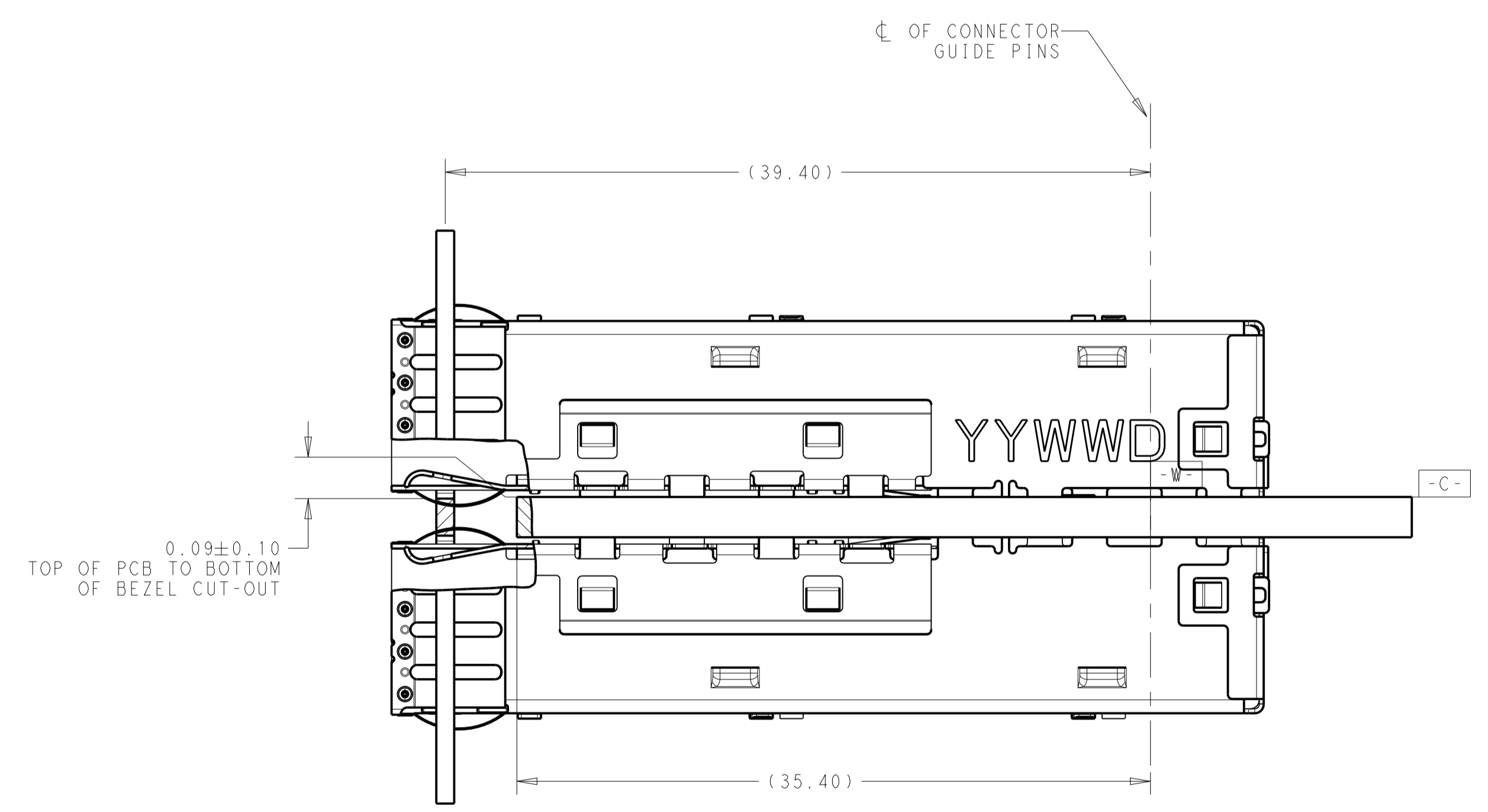

MOUNTED ON BELLY TO BELLY PC BOARD
 SHOWN THRU RECOMMENDED BEZEL
 SCALE 4:1

THIS DRAWING IS A CONTROLLED DOCUMENT.		OWN: IVAN TIAN 14JAN2019	TE Connectivity
DIMENSIONS: mm		CHK: SEAN HAN 14JAN2019	
TOLERANCES UNLESS OTHERWISE SPECIFIED:		APP'D: SEAN HAN 14JAN2019	NAME: 1X3 ZSFP+ CAGE ASSEMBLY
0 PLC ±	1 PLC ±0.25	PRODUCT SPEC	PRESS FIT, GASKET
2 PLC ±0.15	3 PLC ±	APPLICATION SPEC	WITH EXTERNAL EMI SPRING
4 PLC ±	ANGLES ±	114-13120	SIZE: CAGE CODE DRAWING NO
MATERIAL: FINISH: *	WEIGHT: -	A107799	RESTRICTED TO
CUSTOMER DRAWING		SCALE: 2:1	SHEET 2 OF 4 REV 3

REVISIONS				
REV	DATE	DESCRIPTION	BY	APP'D
-	-	SEE SHEET 1	-	-

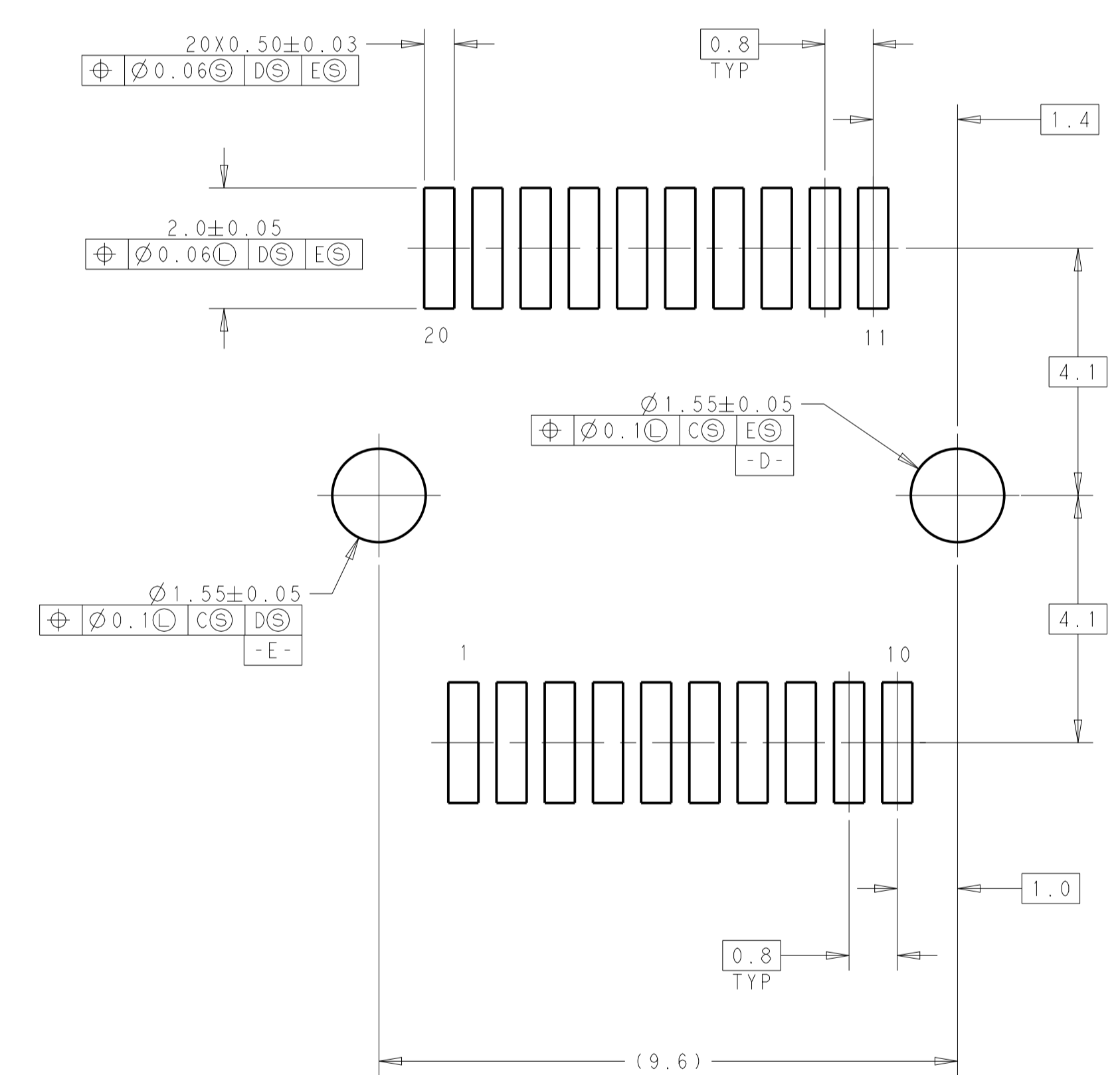
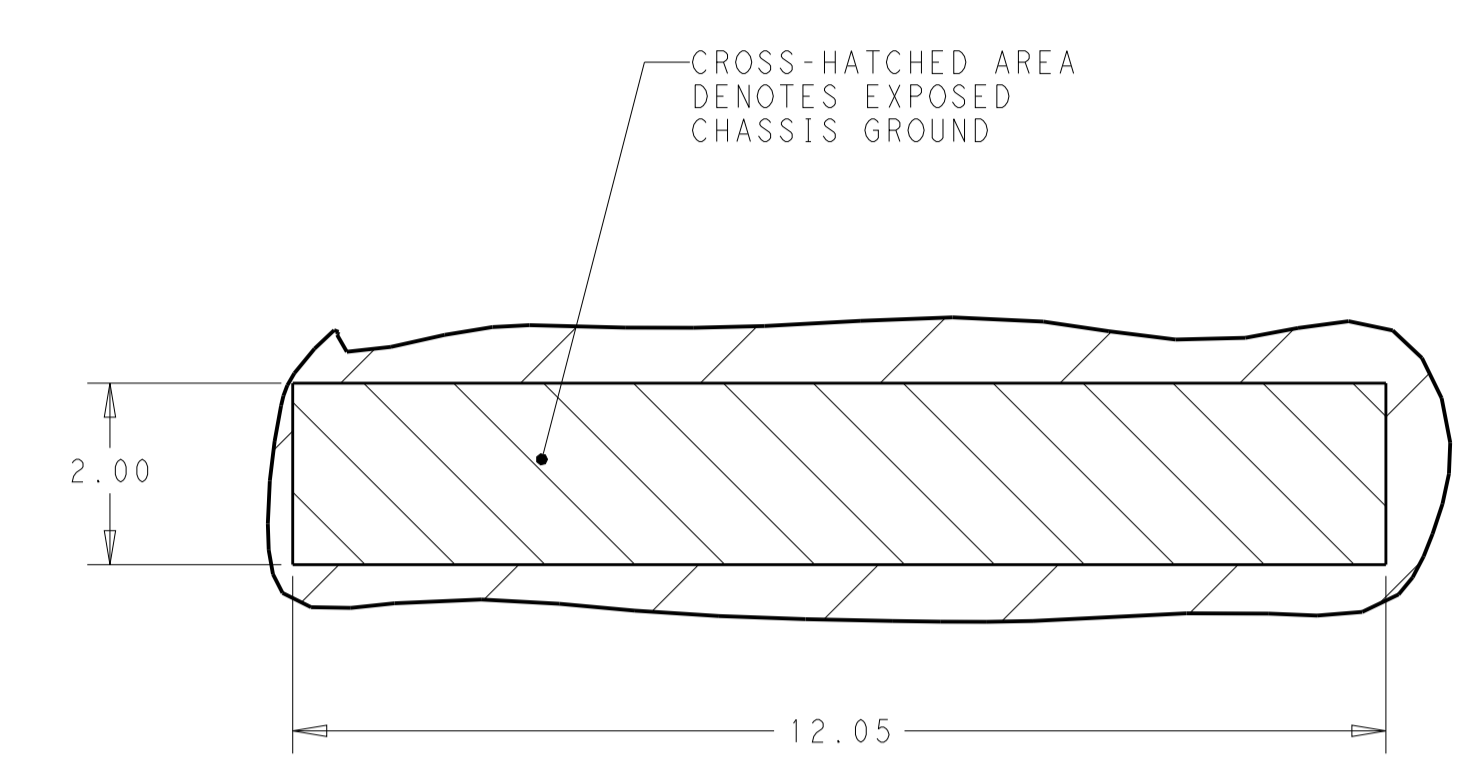
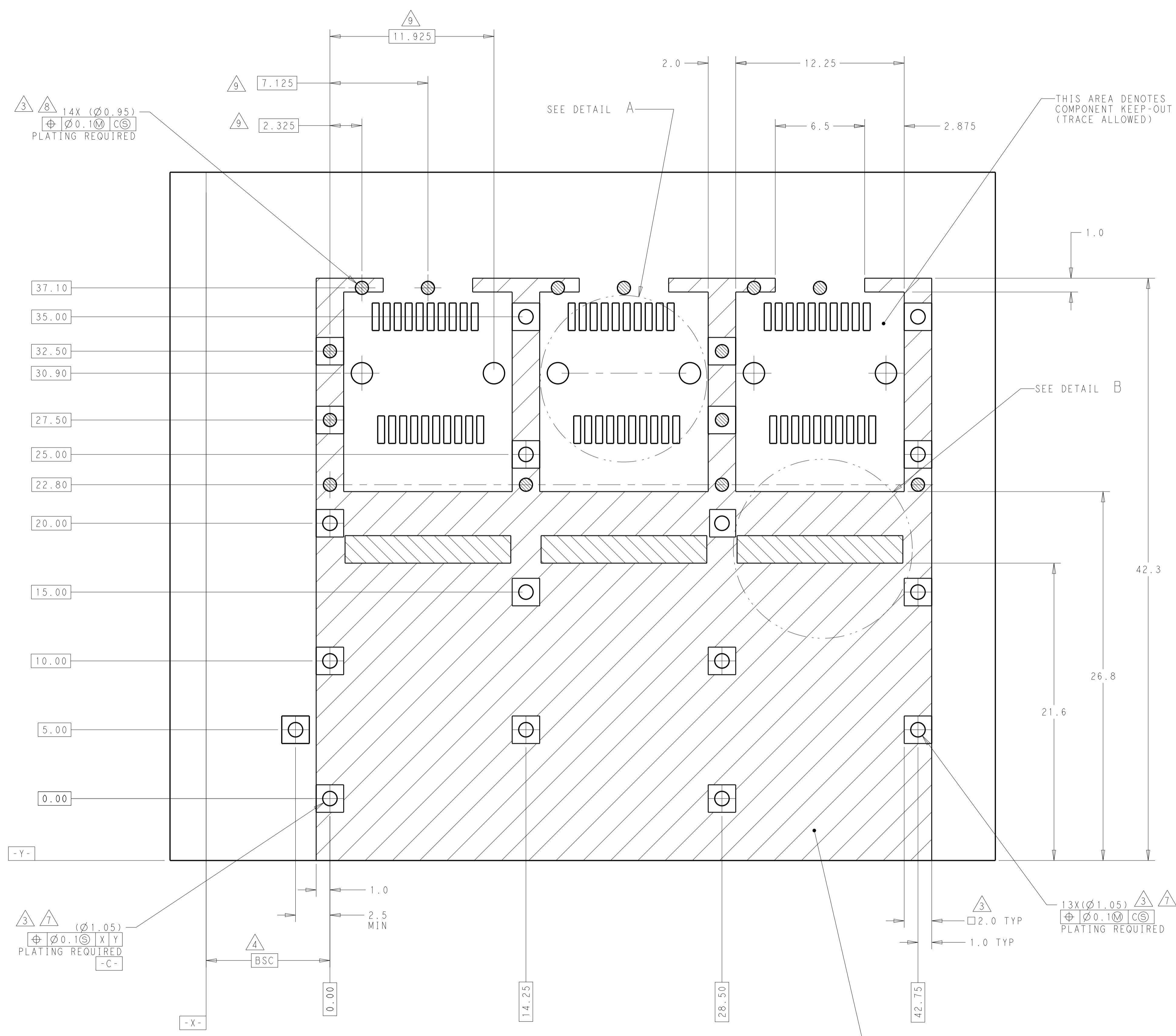

RECOMMENDED PCB CONFIGURATION WITH KEEP-OUT AREAS SINGLE SIDED APPLICATION SCALE 4:1

CROSS-HATCHED AREA DENOTES COMPONENT AND TRACE KEEP-OUT (EXCEPT CHASSIS GROUND)

DETAIL A RECOMMENDED PT CONNECTOR LAYOUT 3X INDIVIDUALLY

THIS DRAWING IS A CONTROLLED DOCUMENT.		OWN: IVAN TIAN 14JAN2019	TE Connectivity
DIMENSIONS: mm		CHK: SEAN HAN 14JAN2019	
TOLERANCES UNLESS OTHERWISE SPECIFIED:		APP'D: SEAN HAN 14JAN2019	NAME: 1X3 ZSFP+ CAGE ASSEMBLY PRESS FIT, GASKET WITH EXTERNAL EMI SPRING
0 PLC ±0.25	1 PLC ±0.15	PRODUCT SPEC: 108-2364	SIZE: CAGE CODE DRAWING NO: A107799C=2349050
2 PLC ±0.15	3 PLC ±0.15	APPLICATION SPEC: 114-13120	RESTRICTED TO: -
4 PLC ±0.15	ANGLES ±1°	WEIGHT: -	SCALE: 2:1 SHEET 3 OF 4 REV 3
MATERIAL: -	FINISH: -	CUSTOMER DRAWING	

REVISIONS				
P.	LTN.	DESCRIPTION	DATE	APPROV.
-	-	SEE SHEET 1	-	-

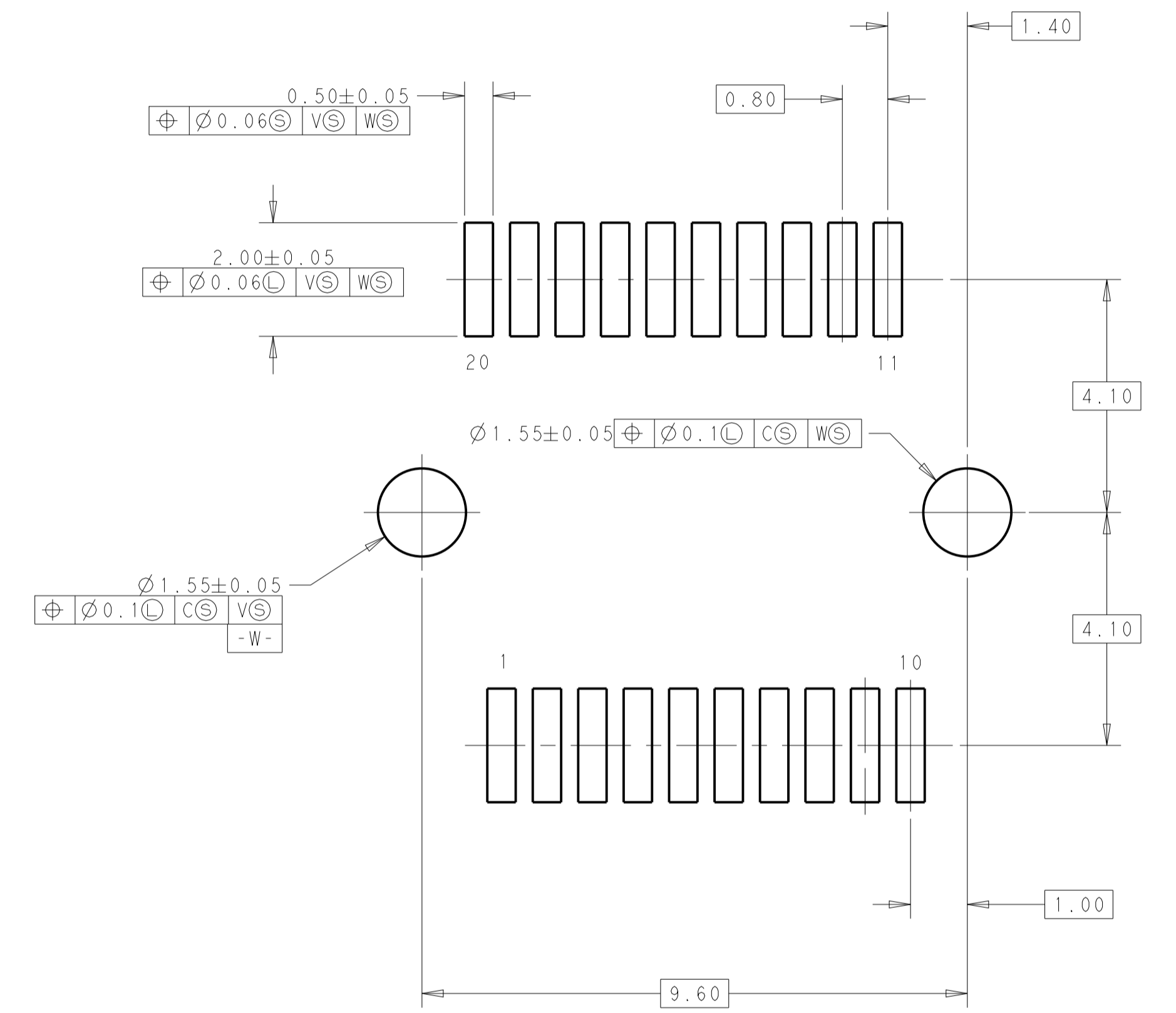
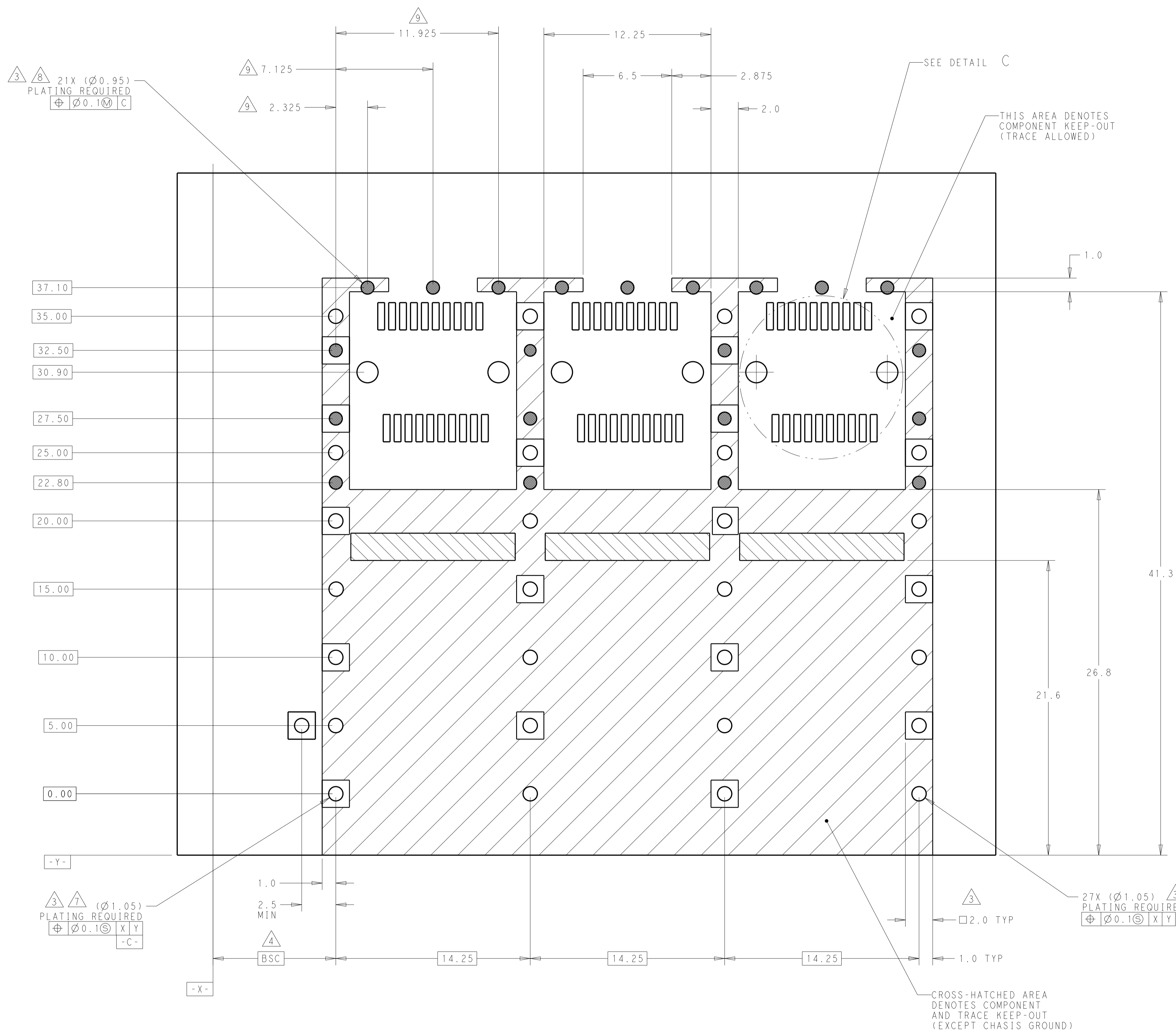

RECOMMENDED PCB CONFIGURATION
 WITH KEEP-OUT AREAS
 BELLY TO BELLY APPLICATION
 SCALE 4:1

THIS DRAWING IS A CONTROLLED DOCUMENT.		OWN: IVAN TIAN 14JAN2019	TE Connectivity
DIMENSIONS: mm		CHK: SEAN HAN 14JAN2019	
TOLERANCES UNLESS OTHERWISE SPECIFIED:		APPR: SEAN HAN 14JAN2019	NAME: 1X3 ZSFP+ GASKET ASSEMBLY PRESS FIT, GASKET WITH EXTERNAL EMI SPRING
0 PLC ±0.25 1 PLC ±0.15 2 PLC ±0.15 3 PLC ±0.15 4 PLC ±0.15 ANGLES ±1°		PRODUCT SPEC: 108-2364 APPLICATION SPEC: 114-13120 WEIGHT: -	
MATERIAL: -		SIZE: 114-13120 CAGE CODE: A107799 DRAWING NO: C=2349050	RESTRICTED TO: -
FINISH: -		CUSTOMER DRAWING	SCALE: 2:1 SHEET: 4 OF 4 REV: 3