

SD5491

Silicon Phototransistor

FEATURES

- TO-18 metal can package
- 12° (nominal) acceptance angle
- Wide operating temperature range (-55°C to +125°C)
- Fast response time
- Wide sensitivity ranges
- External base connection for added control
- Mechanically and spectrally matched to SE3450/5450, SE3455/5455 and SE3470/5470 infrared emitting diodes

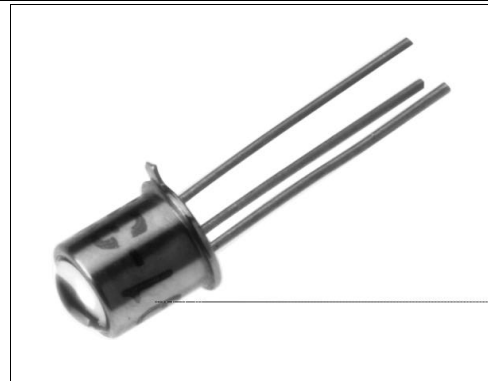

INFRA-70.TIF

DESCRIPTION

The SD5491 is an NPN silicon phototransistor mounted in a TO-18 metal can package. A biconvex lens provides high optical sensitivity with a narrow acceptance angle to enable maximum radiation coupling. The TO-18 package offers protection against harsh environments as well as excellent thermal characteristics.

OUTLINE DIMENSIONS in inches (mm)

Tolerance 3 plc decimals ±0.005(0.12)
2 plc decimals ±0.020(0.51)

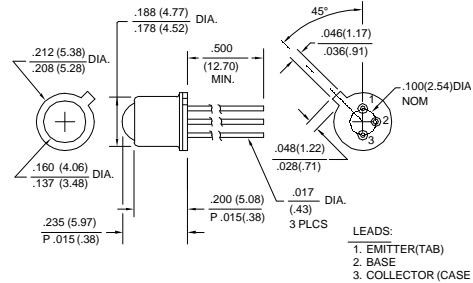

DIM_016.dwg

SD5491

Silicon Phototransistor

ELECTRICAL CHARACTERISTICS (25°C unless otherwise noted)

PARAMETER	SYMBOL	MIN	TYP	MAX	UNITS	TEST CONDITIONS
Light Current	I_L				mA	$V_{CE}=5\text{ V}$ $H=1.5\text{ mW/cm}^2$ (1)
SD5491-001		0.50				
SD5491-002		0.50	3.00			
SD5491-003		2.00	5.00			
SD5491-004		4.00	8.00			
SD5491-005		7.00	22.0			
SD5491-006	15.0					
Collector Dark Current	I_{CEO}			100	nA	$V_{CE}=10\text{ V}, H=0$
Collector-Emitter Breakdown Voltage	$V_{(BR)CEO}$	30			V	$I_C=100\text{ }\mu\text{A}$
Emitter-Collector Breakdown Voltage	$V_{(BR)ECO}$	5.0			V	$I_E=100\text{ }\mu\text{A}$
Collector-Emitter Saturation Voltage	$V_{CE(SAT)}$			0.4	V	$I_C=0.4\text{ mA}$ $H=1.5\text{ mW/cm}^2$
Angular Response (2)	\emptyset		12		degr.	$I_F=\text{Constant}$
Rise And Fall Time	t_r, t_f		2.0		μs	$V_{CC}=5\text{ V}, I_L=1\text{ mA}$ $R_L=100\text{ }\Omega$

Notes

- The radiation source is an IRED with a peak wavelength of 935 nm.
- Angular response is defined as the total included angle between the half sensitivity points.

ABSOLUTE MAXIMUM RATINGS

(25°C Free-Air Temperature unless otherwise noted)

Collector-Emitter Voltage	30 V
Emitter-Collector Voltage	5 V
Power Dissipation	150 mW (1)
Operating Temperature Range	-55°C to 125°C
Storage Temperature Range	-65°C to 150°C
Soldering Temperature (10 sec)	260°C

Notes

- Derate linearly from 25°C free-air temperature at the rate of 1.43 mW/°C.

SCHEMATIC

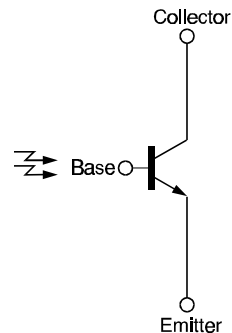

Honeywell reserves the right to make changes in order to improve design and supply the best products possible.

Honeywell

113

SD5491

Silicon Phototransistor

SWITCHING TIME TEST CIRCUIT

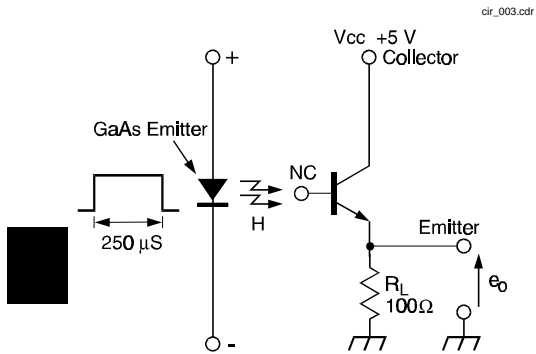

Fig. 1 Responsivity vs Angular Displacement

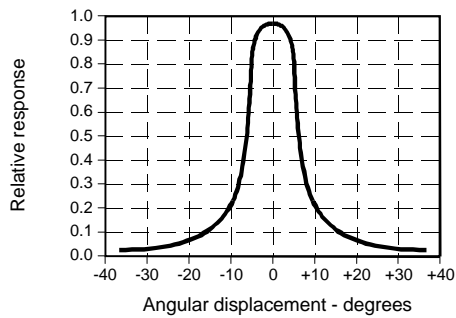

Fig. 3 Dark Current vs Temperature

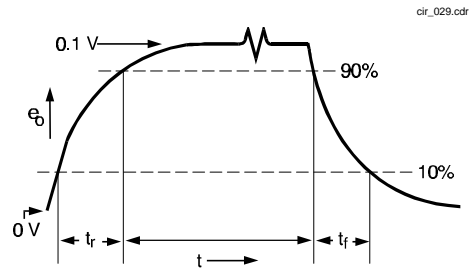
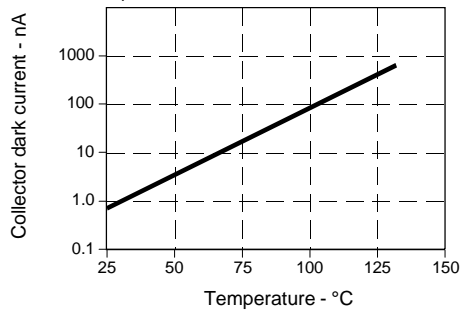

Fig. 2 Collector Current vs Irradiance

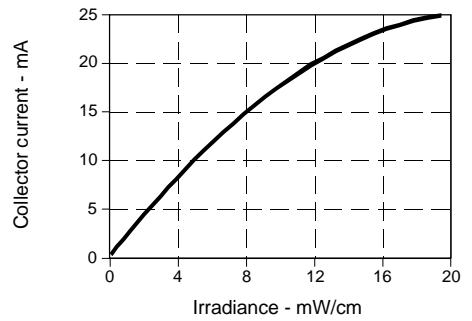
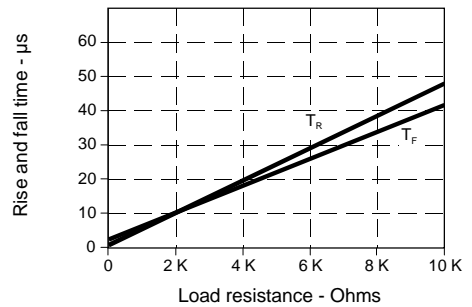

Fig. 4 Rise and Fall Time vs Load Resistance



SD5491

Silicon Phototransistor

Fig. 5 Spectral Responsivity

gra_036.ds4

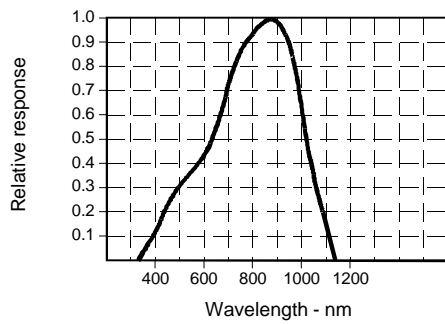

Fig. 6 Coupling Characteristics with SE5470

gra_046.ds4

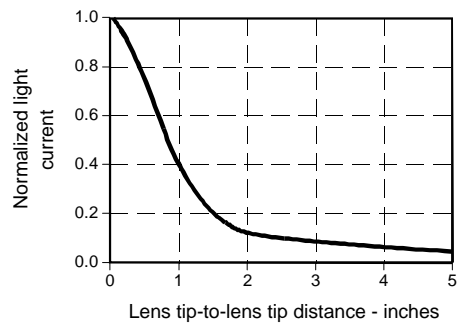
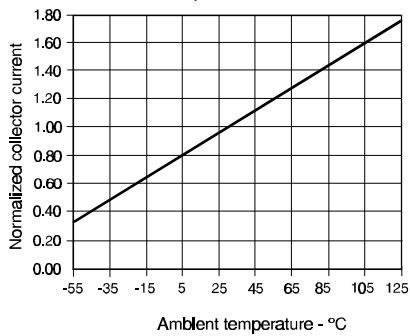

Fig. 7 Collector Current vs Ambient Temperature

gra_302.cdr



All Performance Curves Show Typical Values

Honeywell reserves the right to make changes in order to improve design and supply the best products possible.

Honeywell