

### Solution Products



TBU-CA085-200-WH



2031-42T-SM-RPLF



CDSOT23-S2004

### Design Kit



PN-DESIGNKIT-16

### Objective

Low voltage differential signaling (LVDS) utilizes a 1.25 V electrical signal. This solution protects LVDS which is exposed to high level surges.

### Solution

- 2 TBU<sup>®</sup> High-Speed Protectors: TBU-CA085-200-WH
- 2 GDTs: 2031-42T-SM-RPLF
- 2 Switching Diode Arrays: CDSOT23-S2004

### Compliance

IEC 61000-4-5; Class 4 and 5; 4000 V / 95 A

### Alternate Recommendations

*Other PortNote<sup>®</sup> Solutions:*

- LVDS: Input Port - Surge Protection
- Specific solutions are also available for lower levels of IEC 61000-4-5 as well as the ITU-T and GR-1089-CORE documents.*

### Benefit

This solution provides line output protection without impairing the LVDS signal up to 3 GHz.

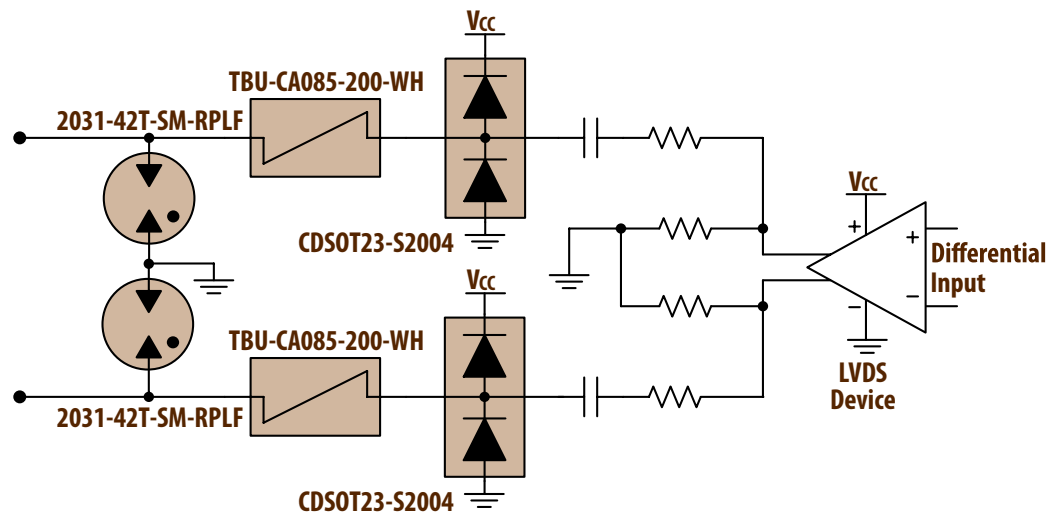

*The schematic above illustrates the application protection and does not constitute the complete circuit design. Customers should verify actual device performance in their specific applications.*