

NS 15 WH PERF 2000MM-VPE 10 - DIN rail perforated



1204096

<https://www.phoenixcontact.com/us/products/1204096>

Please be informed that the data shown in this PDF document is generated from our Online Catalog. Please find the complete data in the user documentation. Our General Terms of Use for Downloads are valid.



DIN rail perforated, acc. to EN 60715, material: Steel, Galvanized, white passivated, Standard profile, color: silver, Pack of 10 (20 m)

Commercial Data

Item number	1204096
Packing unit	1 m
Minimum order quantity	10 m
Sales Key	BE72
Product Key	BE7223
Catalog Page	Page 523 (C-3-2019)
GTIN	4017918106430
Weight per Piece (including packing)	308 g
Weight per Piece (excluding packing)	308 g
Customs tariff number	72166190
Country of origin	DE

NS 15 WH PERF 2000MM-VPE 10 - DIN rail perforated



1204096

<https://www.phoenixcontact.com/us/products/1204096>

Technical Data

Product properties

Product type	DIN rail
--------------	----------

Dimensions

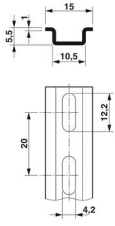
Dimensional drawing	
Width	15 mm
Hole width	12.2 mm
Height	2000 mm
Hole height	4.2 mm
Depth	5.5 mm
Length	2000 mm
Drill hole spacing	20 mm

Material specifications

Color	silver
Material	Steel
Coating	Galvanized, white passivated

Standards and regulations

Connection in acc. with standard	IEC / EN
Tests	acc. to EN 60715

NS 15 WH PERF 2000MM-VPE 10 - DIN rail perforated



1204096

<https://www.phoenixcontact.com/us/products/1204096>

Drawings

Dimensional drawing

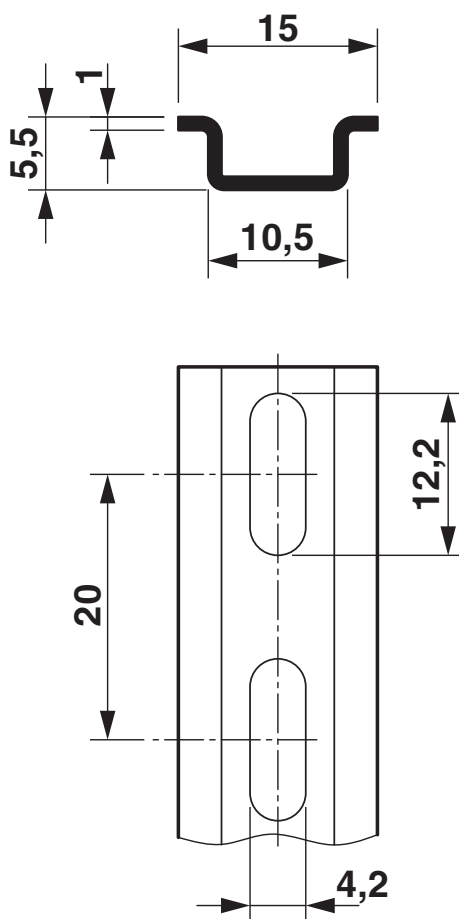

NS 15 WH PERF 2000MM-VPE 10 - DIN rail perforated



1204096

<https://www.phoenixcontact.com/us/products/1204096>

Classifications

ECLASS

ECLASS-11.0	27400602
ECLASS-13.0	27400602
ECLASS-12.0	27400602

ETIM

ETIM 8.0	EC001285
----------	----------

UNSPSC

UNSPSC 21.0	39121700
-------------	----------

NS 15 WH PERF 2000MM-VPE 10 - DIN rail perforated



1204096

<https://www.phoenixcontact.com/us/products/1204096>

Environmental Product Compliance

China RoHS	Environmentally friendly use period: unlimited = EFUP-e
	No hazardous substances above threshold values

Phoenix Contact 2023 © - all rights reserved
<https://www.phoenixcontact.com>

Phoenix Contact USA
586 Fulling Mill Road
Middletown, PA 17057, United States
(+717) 944-1300
info@phoenixcon.com