

Q22 series

Ø22 mm panel mount LED indicators



DISTINCTIVE FEATURES

16.75 mm colored diffused epoxy lens or 16.75 mm super bright LEDs

Secret until lit polycarbonate decals or custom engraving
(2.8 x 0.8) solder lug/faston terminals, pins or (200 mm long)
wire terminations

Available in RGB



ENVIRONMENTAL SPECIFICATIONS

- IP67 sealing option (EN60529)
- Operating & Storage Temperature Range:
Rear plastic body: -30 °C to +65 °C (-22 °F to +149 °F)
Rear epoxy body: -40 °C to +85 °C (-40 °F to +185 °F)



GENERAL SPECIFICATIONS

- Max Reverse Voltage: 5 V
- Viewing Angle: 30–100° (dependant on model)
- Life Expectancy: 100,000 hours
- Torque: 75 cNm
- Maximum panel thickness:
12 mm (Prominent & Recessed),
10 mm (Flush & Chamfered)
- Insulation resistance : 4,000 MΩ at 500 VDC



MOUNTING

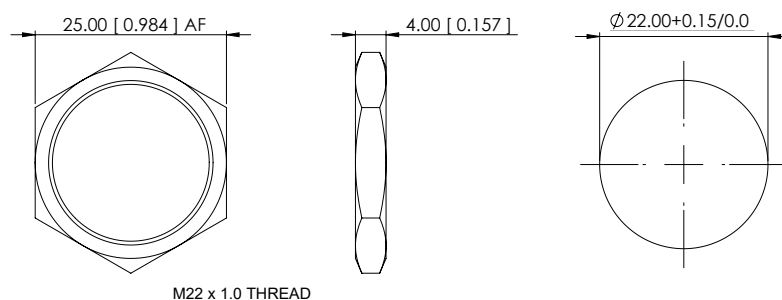

The company reserves the right to change specifications without notice.

All LED characteristics are dependent upon environmental conditions. Therefore published data should be considered nominal and subject to variations.



Q22 series

Ø22 mm panel mount LED indicators



MATERIALS

- Plated brass bezel finished in bright chrome, black or satin grey and moulded polycarbonate rear body.



ELECTRICAL SPECIFICATIONS

STANDARD LED INTENSITY

LED COMPONENT SPECIFICATIONS			
	Prominent and Recessed	Flush	Forward Voltage
HE Red	82 mcd	70 mcd	5.7 V
Green	95 mcd	66 mcd	6.0 V
Yellow	60 mcd	59 mcd	5.9 V
Blue	120 mcd	101 mcd	9.9 V
White	1,000 mcd	150 mcd	3.3 V
Bi-color (Typical) (Red/Green)	80/50 mcd	80/50 mcd	2.0 V/2.2 V
Tri-color (Typical) (Red/Green/Yellow)	80/50/50 mcd	80/50/50 mcd	2.0 V/2.2 V/2.1 V

Bi-color - The color is changed by reversing the polarity of the supply voltage.

Tri-color - The indicator has red and green LEDs, when both connected yellow is produced.

SUPER BRIGHT LED INTENSITY

LED COMPONENT SPECIFICATIONS			
	Prominent and Recessed	Flush	Forward Voltage
HE Red	465 mcd	800 mcd	5.7 V
Green	245 mcd	980 mcd	9.0 V
Yellow	365 mcd	1,250 mcd	6.0 V

RGB LED INTENSITY

ITEM	SYMBOL	CONDITION	TYP.
DC Forward Voltage	$V_F(R)$	IF=20 mA	2.1
	$V_F(B/G)$	IF=20 mA	3.1
Luminous Intensity	I_v (Red)		220 mcd
	I_v (Green)		500 mcd
	I_v (Blue)		100 mcd



CONNECTIONS

REAR EPOXY WIRES FOR RGB OPTION

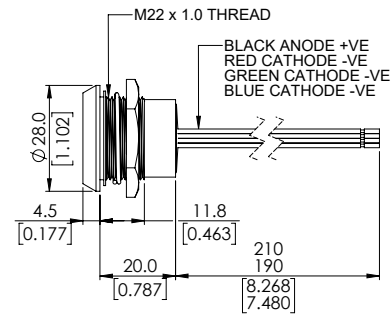

Voltage	Operating Voltage	Operating Current
	(Min to Max)	(Typical All Types)
05 (No Resistor)	3.3 to 9.9 VDC	40 mA max*
12 VDC	10.8 to 13.2 VDC	40 mA
24 VDC	21.6 to 26.4 VDC	40 mA
28 VDC	25.2 to 30.8 VDC	40 mA
110 VAC	99 to 121 VAC	5 mA
220 VAC	207 to 235 VAC	3 mA

* Customer to supply resistor for desired operating current.

ADDITIONAL INFORMATION ON LED COMPONENTS

- Bi-color leds, by connecting the gold faston (+) one color is produced, by reversing the supply voltage another color is produced – bi-colors are available up to 28 VDC
- The tri-color led has red and green leds when both are connected yellow is produced
- The operating voltage must not be exceeded by more than 10% as this will result in reduced life expectancy
- Luminous intensity is measured at 20 mA on a discrete led unless otherwise stated.
- Luminous intensities and color shades of white LEDs may vary within a batch.
- Luminous intensity will be reduced with lower operating current.
- Recommended usage:
 - Standard: Homogenous light output that is good for indoor applications.
 - Super Bright: Homogenous light output that is good for outside viewing and is daylight visible.

Q22 series

Ø22 mm panel mount LED indicators



BUILD YOUR PART NUMBER

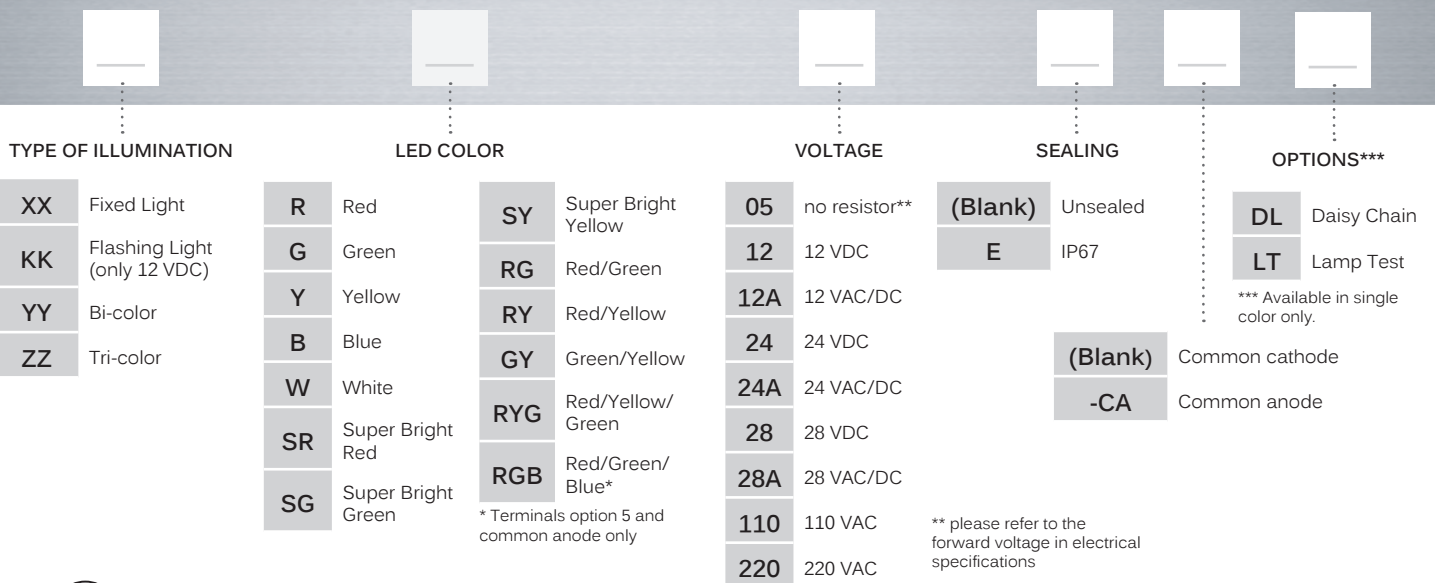
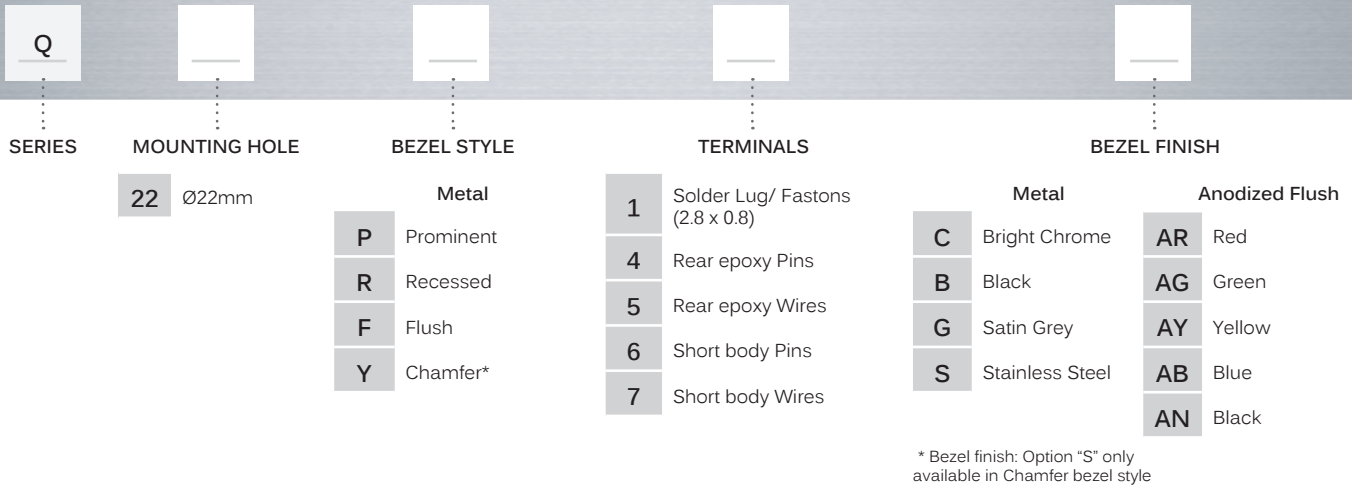

ABOUT THIS SERIES

- Notice:** please note that not all combinations of above numbers are available.
- Gold faston terminal denotes anode (+), silver terminal denotes cathode (-)
 - Standard and Bi-Colour are provided in Standard wire length is 200mm, 24AWG UL1061, Red wire denotes anode (+), Black wire denotes cathode (-) for other lengths consult APEM.
 - For leds with alternative voltages please consult Apem
 - 110 VAC and 220 VAC, only available with terminal options 1 and 5
 - Take care when soldering to the faston terminals (recommended solder temperature 300 °C - 3 sec)
 - Pin and Wire options are epoxy sealed at the rear of the bezels, termination options 4 and 5
 - Standard tri-color faston terminals are two anodes (+) and one cathode (-)
 - Tri-color wires are one red (+) and one green (+) anode and one black (-) cathode
 - Tri-color pins are center (-) cathode, shortest (+) anode pin green, longest (+) anode pin red
 - Daisy chaining option - has negative (Cathode) terminals linked (3 x Fastons), solder lugs only
 - Lamp test facility option 4 x solder lug/Faston only
 - We recommend using superbright leds for use at 110 VAC and 220 VAC

Q22 series

Ø22 mm panel mount LED indicators

PROMINENT BEZEL

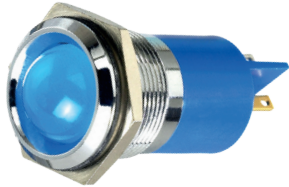

REAR EPOXY WIRES

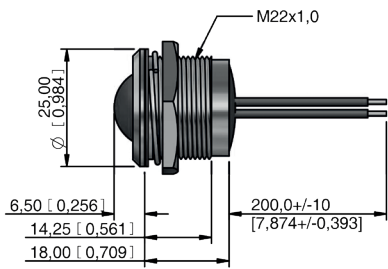

SHORT BODY WIRES

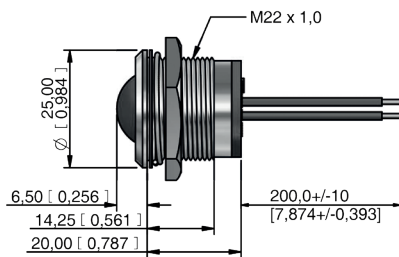

SOLDER LUG/FASTON

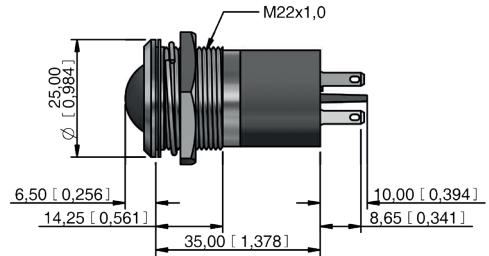

REAR EPOXY PINS

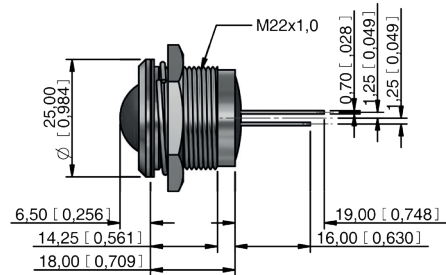

SHORT BODY PINS

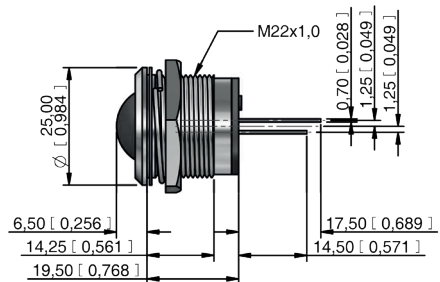

Q22 series

Ø22 mm panel mount LED indicators

FLUSH BEZEL

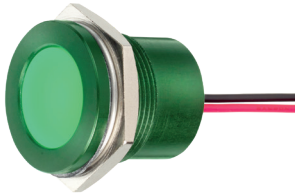

REAR EPOXY WIRES

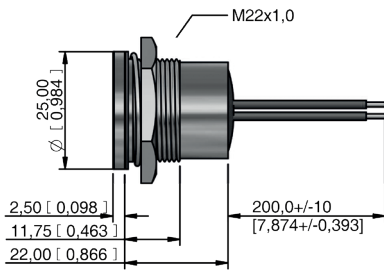

SHORT BODY WIRES

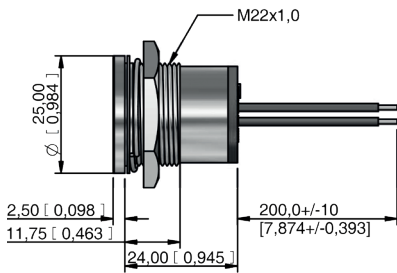

SOLDER LUG/FASTON

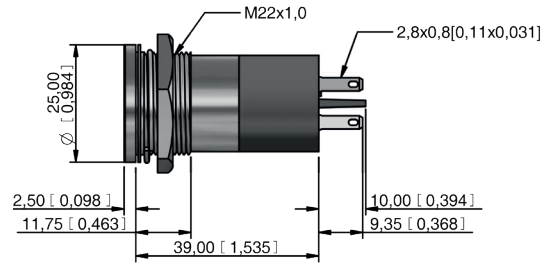

REAR EPOXY PINS

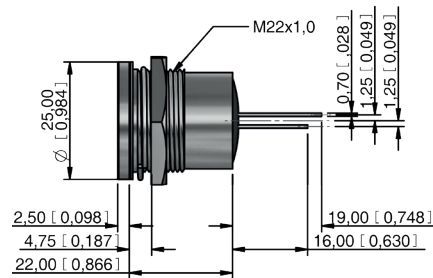

SHORT BODY PINS

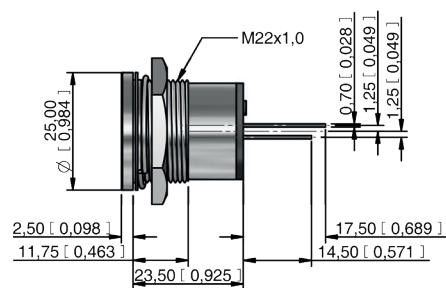

Q22 series

Ø22 mm panel mount LED indicators

RECESSED BEZEL



REAR EPOXY WIRES

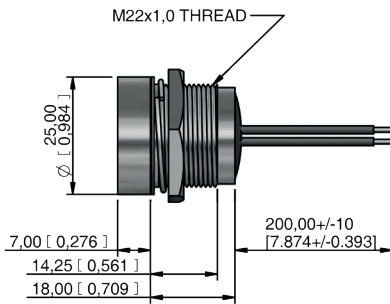

SHORT BODY WIRES

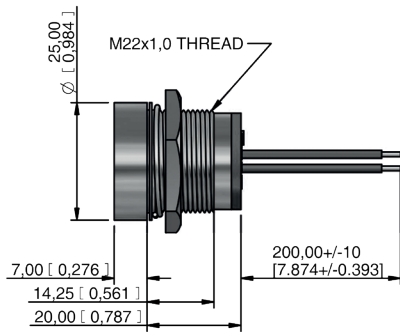

SOLDER LUG/FASTON

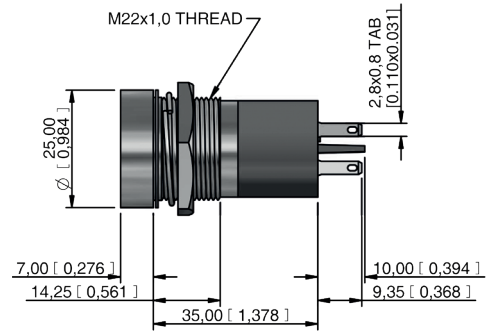

PINS

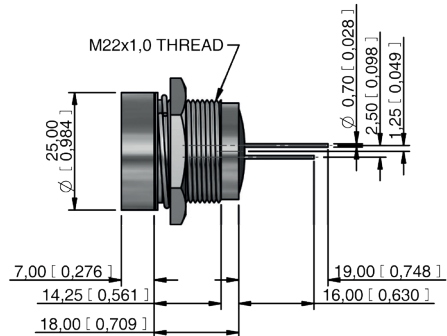

REAR EPOXY PINS

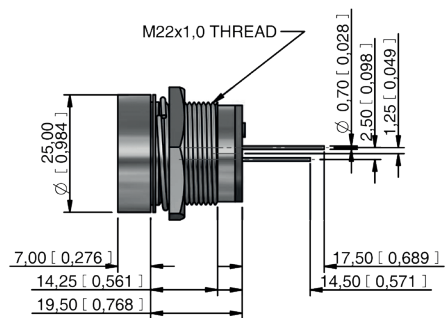

Q22 series

Ø22 mm panel mount LED indicators

CHAMFER BEZEL

(316L STAINLESS STEEL AND ANODIZED ALUMINIUM ONLY)



SOLDER LUG/FASTON

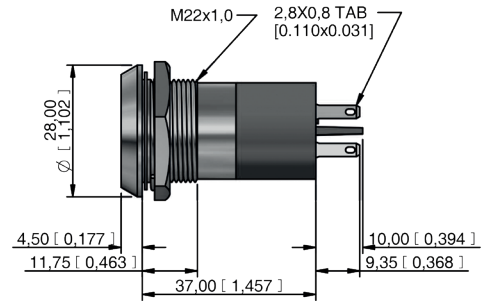

REAR EPOXY WIRES

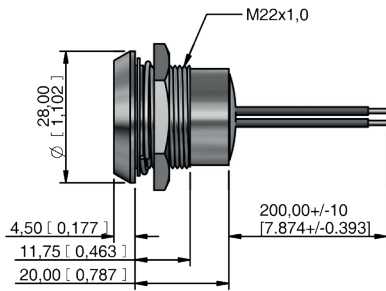

PINS

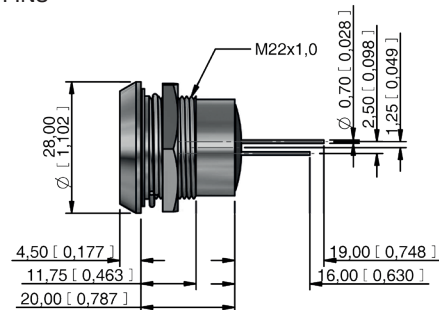

SHORT BODY WIRES

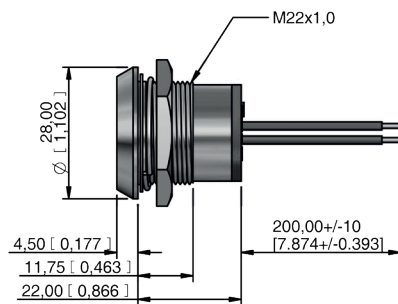

REAR EPOXY PINS

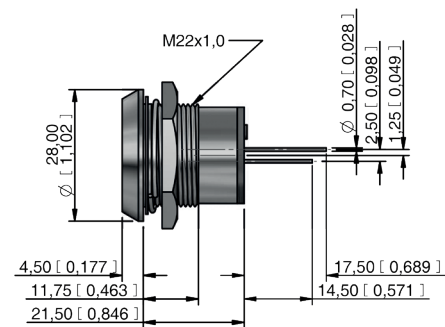

Q22 series

Ø22 mm panel mount LED indicators



CUSTOM ENGRAVING

Some common codes are listed above, for your custom requirements please contact APEM.
Unless specified standard engraving with white infill will be supplied.
Suffix the part number with legend code :



High beam
-0AJ



Low beam
-097



Rear fog
-027



Front fog
-026



Windscreen
wiper
-021



Windscreen
washer
-022



Ventilator
fan
-023



Turn Signal
-0AH



Side lights
-098



Horn
-041



Hazard
warning
-013



Heating
-018



Brake test
-0BU



Arrow
-0K6



Battery
-0AG



Oil can
-0GP



Windscreen
heating
-020



ABS
-086



Engine coil
-0EL



Seat belt
-0SB



USB
connection
-0BU



Steam
-0ST



ECU
-0EU



Side step
-0AD



Air con
-012



Engine
-040



Boot/Trunk
Release
-0BR



Q22 series

Ø22 mm panel mount LED indicators



SECRET UNTIL LIT POLYCARBONATE INSERTS

Some common codes are listed above, for your custom requirements please contact APEM. Please note Secret until lit inserts only available with flush metal bezel (Option F)
Suffix the part number with legend code :

 Turn signal -3AH	 Hazard -3I3	 Oil can -3GP	 Battery -3AG	 Rear fog -327	 Low beam -397	 Brake test -3BU
 Arrow -3K6	 High beam -3AJ	 Park brake -3PB	 Side lights -398	 Seat belt -3SB	 Type pressure -3TP	 Check engine -3CE
 Engine temperature -3EC	 Fuel -3FP	 BRAKE FAILURE Brake failure -3BF	 Off	 On		



CABLE LENGTH AND CONNECTOR



For custom cable length and connectors contact APEM.