

rev	ecn no	dr	date
A	V05-0062	TAB	01/19/05
B	V05-0052	VS	10/14/05
C	V06-0558	LP	2006/06/12
D	V07-0440	LP	2007-07-05

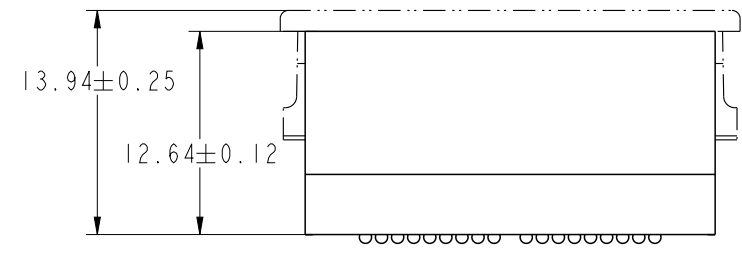
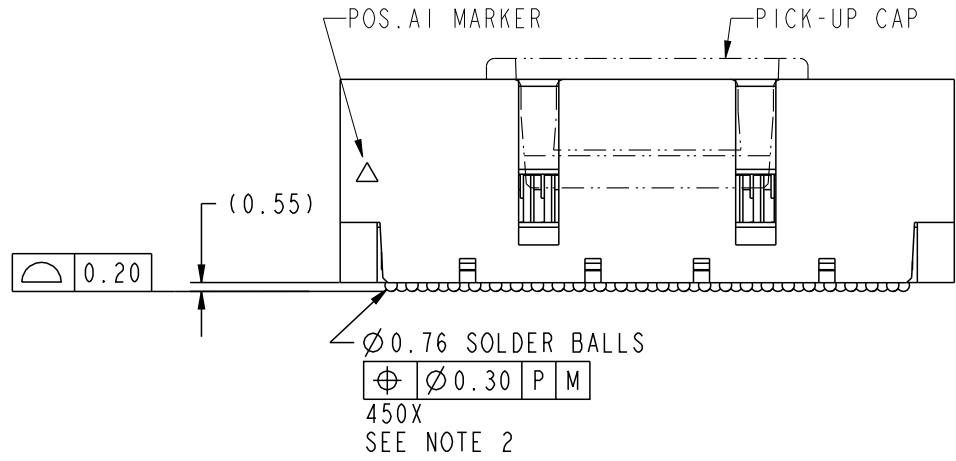
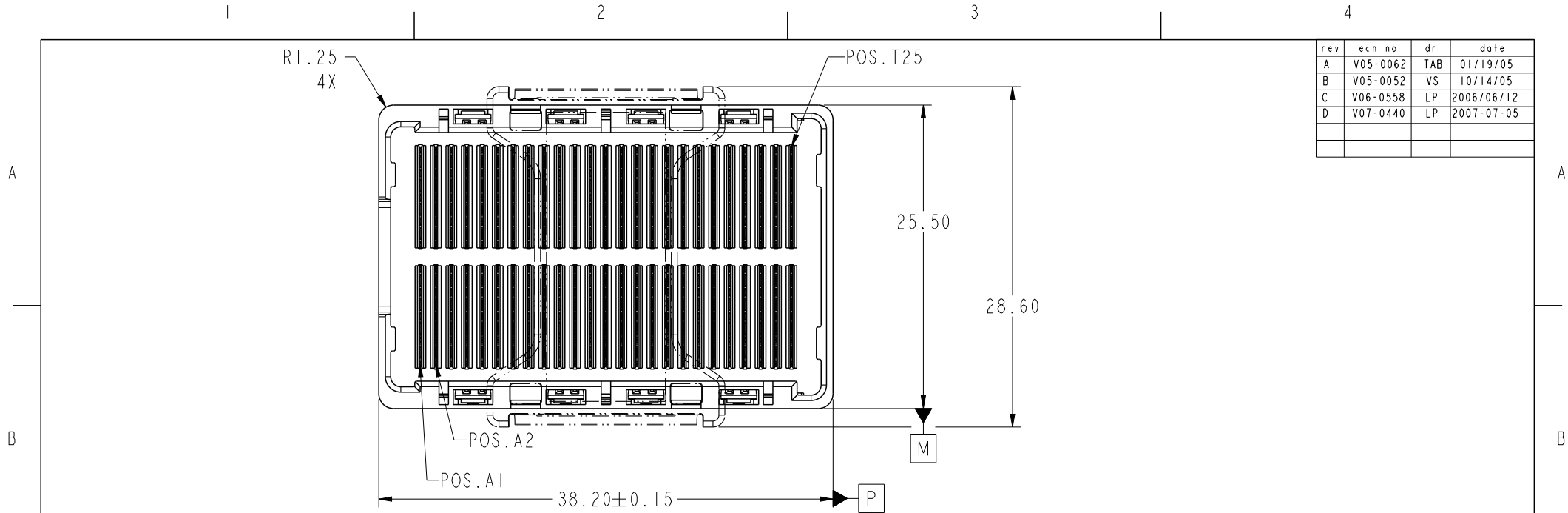

Copyright FCI.

spec ref	-			dr	Louis Ng	2010/11/01	projection 	mm 	size	A4	scale	1:1		
tolerance std	ASME Y14.5			eng	Nickor Zuo	2011/06/13			ecn no	ELX-DG-003943-1				
surface	TOLERANCES UNLESS OTHERWISE SPECIFIED			chr	Alex Cao	2011/06/24			product family	GIG-Array		rel level	Released	
	linear	0.X	±0.30	appr	Pei-Ming Zheng	2011/06/27	title		GIG-Array		dwg no	10030626	rev	E
	angular	0°	±2°	www.fci.com		cat. no.	Product - Customer Drw			sheet 1 of 5				

ProjE File - REV C - 2009-06-09



Copyright FCI.

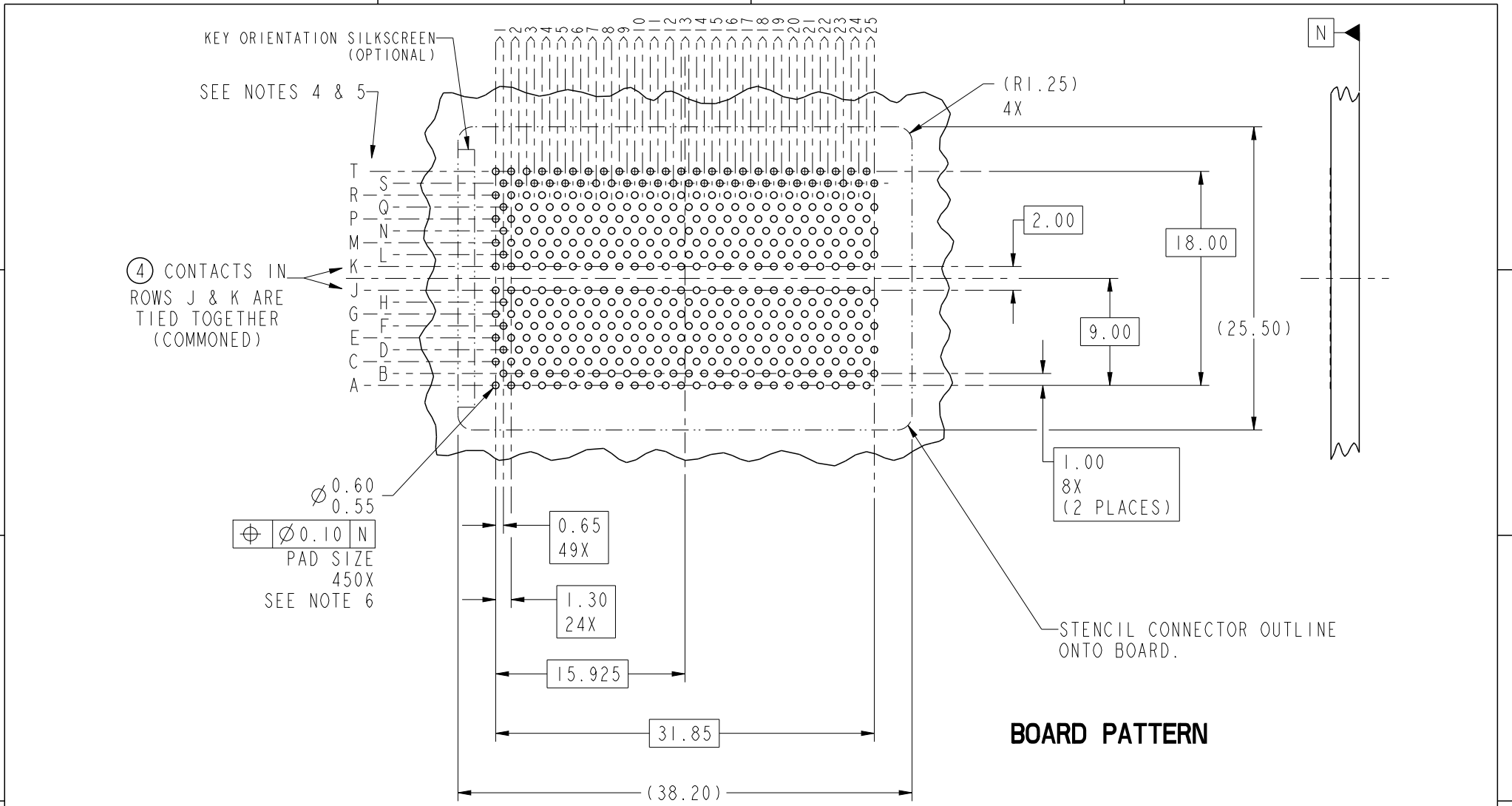

**BOARD PATTERN**

spec ref	-	dr	Louis Ng	2010/11/01	projection	mm	size	A4	scale	1:1												
tolerance std	ASME Y14.5	eng	Nickor Zuo	2011/06/13			ecn no		ELX-DG-003943-1													
TOLERANCES UNLESS OTHERWISE SPECIFIED		chr	Alex Cao	2011/06/24			rel level		Released													
surface	<table border="1"> <tr><td>linear</td><td>0.X</td><td>±0.30</td></tr> <tr><td></td><td>0.XX</td><td>±0.10</td></tr> <tr><td></td><td>0.XXX</td><td>±0.05</td></tr> <tr><td>angular</td><td>0°</td><td>±2°</td></tr> </table>	linear	0.X	±0.30		0.XX	±0.10		0.XXX	±0.05	angular	0°	±2°	appr	Pei-Ming Zheng	2011/06/27	product family		GIG-Array		rev	E
linear	0.X	±0.30																				
	0.XX	±0.10																				
	0.XXX	±0.05																				
angular	0°	±2°																				
				title		GIG-Array		10030626														
		www.fci.com		cat. no.		Product - Customer Drw		sheet 2 of 5														

PrdE File - REV C - 2009-06-09

1

2

3

4

A

B

C

D

A

B

C

D

D1  
SIGNAL/GROUND

C1  
GROUND

B1  
SIGNAL/GROUND

A1  
GROUND

A2  
GROUND

A3  
GROUND

B2-B3  
DIFFERENTIAL PAIR  
TYPICAL

### PLUG INTERFACE DESCRIPTION

spec ref	-			dr	Louis Ng	2010/11/01	projection	mm ←→	size	A4	scale	1:1		
tolerance std	ASME Y14.5			eng	Nickor Zuo	2011/06/13			ecn no	ELX-DG-003943-1				
surface	✓	linear	0.X ±0.30 0.XX ±0.10 0.XXX ±0.05	chr	Alex Cao	2011/06/24			product family	GIG-Array		rel level	Released	
-	angular	0°	±2°	appr	Pei-Ming Zheng	2011/06/27	title		GIG-Array		dwg no	10030626	rev	E
				www.fci.com		cat. no.	Product - Customer Drw			sheet 3 of 5				

PrdE File - REV C - 2009-06-09



Copyright FCI.

**FLAT AREA  
PICK-UP CAP**

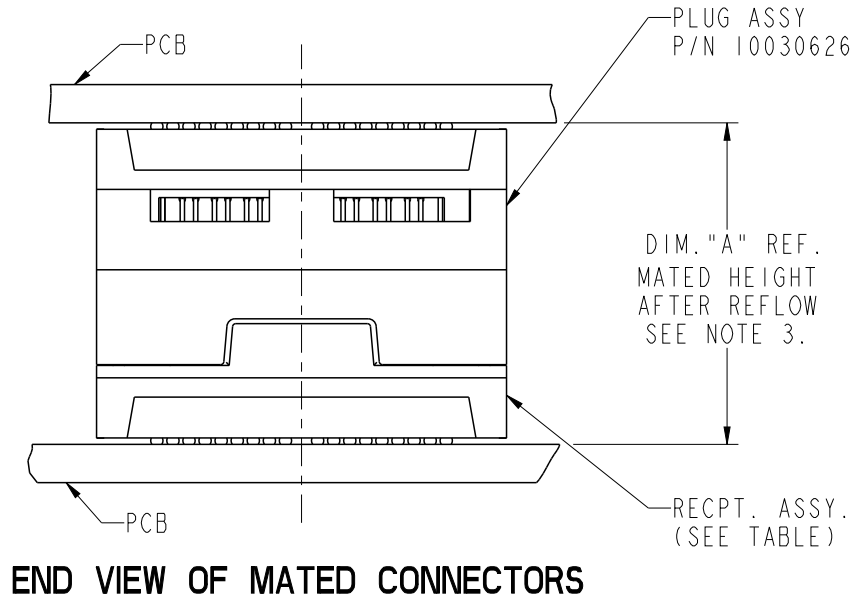
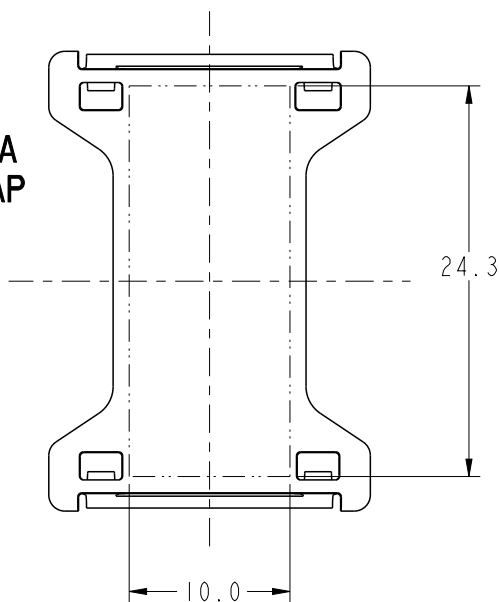

**END VIEW OF MATED CONNECTORS**

DIM. "A"	RECPT. ASSY. P/N
18	55740
23	10026010
28	55741

NOT TOOLED

spec ref		-		dr	Louis Ng	2010/11/01	projection 	mm 	size	A4	scale	1:1
tolerance std	ASME Y14.5	TOLERANCES UNLESS OTHERWISE SPECIFIED			eng	Nickor Zuo			2011/06/13	ecn no	ELX-DG-003943-1	
					chr	Alex Cao			2011/06/24		rel level	Released
surface	✓	linear	0.X	±0.30	FCj 	title			GIG-Array	13mm PLUG ASSY. 200 SIG. POS.		dwg no
		0.XX	±0.10									
		0.XXX	±0.05									
		angular	0°	±2°	www.fci.com	cat. no.	Product - Customer Drw		sheet 4 of 5			

PrdE File - REV C - 2009-06-09

PRODUCT NUMBER	SOLDER BALL COMPOSITION	CONTACT PLATING PERFORMANCE LEVEL
10030626-001	STANDARD (EUTECTIC)	PERFORMANCE-BASED PLATING, QUALIFIED TO MEET THE REQUIREMENTS OF FCI PRODUCT SPECIFICATION GS-12-192, INCLUDING TELCORDIA CENTRAL OFFICE  Au over Ni
10030626-001LF	LEADFREE	
10030626-201	STANDARD (EUTECTIC)	
10030626-201LF	LEADFREE	

NOTES:

- ① MATERIAL:  
HOUSING: LCP  
CONTACT: COPPER ALLOY  
PLATING (CONTACT): Au OVER Ni.  
UL RATING: 94 V-0  
SOLDER BALL: (SEE TABLE) EUTECTIC SnPb OR LEADFREE 95.5 Sn/4Ag/0.5Cu
- ② SOLDER BALLS WILL NOT BE PERFECT SPHERICAL SHAPE DUE TO REFLOW ATTACHMENT.
- ③ MATED HEIGHT EFFECTED BY CUSTOMERS' PCB PAD SIZE, PLATING, SOLDER REFLOW PROFILE & SOLDER PASTE.
- ④ CONTACTS IN ROWS A,C,E,G,J,K,M,P,R AND T ARE SINGLE BEAM CONTACTS, TYPICALLY USED AS GROUND PINS. (NOTE: CONTACTS IN ROWS J & K ARE TIED TOGETHER [COMMONED])
- ⑤ CONTACTS IN ROWS B,D,F,H,L,N,Q AND S ARE DUAL BEAM CONTACTS, TYPICALLY USED AS SIGNAL PINS.

NOTES CONTINUED

- ⑥ SPECIFIED POSITIONAL TOLERANCE DEFINES PAD TO PAD LOCATION WITHIN LAND PATTERN. POSITIONAL TOLERANCE OF LAND PATTERN TO FUDICIAL MARKS OR PCB DATUMS SHALL BE DEFINED BY CUSTOMER. FOR RECOMMENDED PRODUCT APPLICATION AND PCB DESIGN DETAILS, SEE DOC. NO. GS-20-016.
- ⑦ FOR PROPER APPLICATION FOLLOW FCI APPLICATION SPECIFICATION GS-20-033 LEADFREE SOLDER BALLS WILL NOT SOLDER PROPERLY IN A LEADED SOLDER PROCESS DUE TO A HIGHER REFLOW TEMPERATURE, LEADFREE PRODUCT IS THEREFORE NOT BACKWARDS COMPATIBLE WITH LEADED OR SOME SOLDERING APPLICATIONS. REFERENCE FCI APPLICATION SPECIFICATION.
- ⑧ THIS PRODUCT MEETS THE EUROPEAN UNION DIRECTIVES AND OTHER COUNTRY REGULATIONS AS DESCRIBED IN GS-22-008. PRODUCT MEETING WITH THES DIRECTIVE IS IDENTIFIED IN THE LOT CODE NUMBER MARKED ON EACH PART BY HAVING AN "X" IN THE SEVENTH CHARACTER POSITION.

spec ref	-	dr	Louis Ng	2010/11/01	projection	mm	size	A4	scale	1:1								
tolerance std	TOLERANCES UNLESS OTHERWISE SPECIFIED	eng	Nickor Zuo	2011/06/13			ecn no	ELX-DG-003943-1										
ASME Y14.5		chr	Alex Cao	2011/06/24				product family	GIG-Array	rel level	Released							
-		appr	Pei-Ming Zheng	2011/06/27							surface	linear	0.X	±0.30	FCI	title	GIG-Array	dwg no
-		angular	0°	±2°				www.fci.com	cat. no.	Product - Customer Drw								

Prod File - REV C - 2009-06-09



Copyright FCI.