

D-Series Inclinometer



- Dual axis inclinometer
- Measurement range $\pm 5^\circ$ $\pm 15^\circ$ and $\pm 30^\circ$
- High accuracy
- Digital and analogue output signal
- CANopen
- CE approved



DESCRIPTION

The **D-series** of conductive inclinometers offers modern SMD- technology in an environmentally protected and robust aluminium housing. The inclinometer achieves high accuracy over a wide temperature range. The fast microcontroller works with a linearization and temperature compensation routines. This full calibrated inclinometer is available with digital output RS 232 and analogue voltage output 0.5 up to 4.5 V or current output 4...20mA or PWM output or switch output signals. Furthermore is inclinometer is available with an CANopen interface.

FEATURES

- High accuracy
- Robust metal housing, IP Class 67/68
- High resolution
- EMC protected
- CE approved
- Rugged M12 male connector
- Programmable digital filtering to minimized influences from shock and vibration
- Programmable zero point, baud rate, output rate

APPLICATIONS

- Building control
- Road construction machines
- Wind power
- Weighing systems
- Mobile and stationary cranes
- Hydraulic leveling
- Platform leveling
- Drilling machines

D-Series Inclinometer

PERFORMANCE SPECS

	Conditions	Min	Type	Max	Unit
Measurement range		-5 (-15,-30)		+5(+15,+30)	°
Resolution		0.001		0.005	°
Accuracy,digital,analogue (absolute)	Ta = +25°C		0.04		°
Accuracy,digital,analogue (absolute)	Ta = -40°C ...+85°C		0.15	(0.3,0.8)	°
Offset temperature drift error	Ta = -40°C...+85°C		0.06		°
Noise RMS			0.001		°
Frequence responce			2	3	Hz
Power supply		10		30	VDC
Operation temperature range		-40		+85	°C
Storage temperature range		-40		+85	°C
Weight			290		g
Dimensions	W x D x H		84 x 70 x 46		mm
Unit with RS 232 interface and analogue output signal					
Transmission rate, programmable		0.1	10	16	Hz
Baud rate, programmable		2.4	9.6	57.6	kB
Current output		20		4	mA
Voltage output		0.5		4.5	V
PWM output	1 KHz	20		80	%
Switch output,programmable	Step		0.1		°
Current consumption			30	40	mA
Unit with CANopen interface					
Baud rate, programmable		0.02	0.25	1	MBaud
Code	Binary				-
Interface	CAN according to CAL				-
Current consumption			50	90	mA

D-Series Inclinometer

DIMENSIONS [MM]

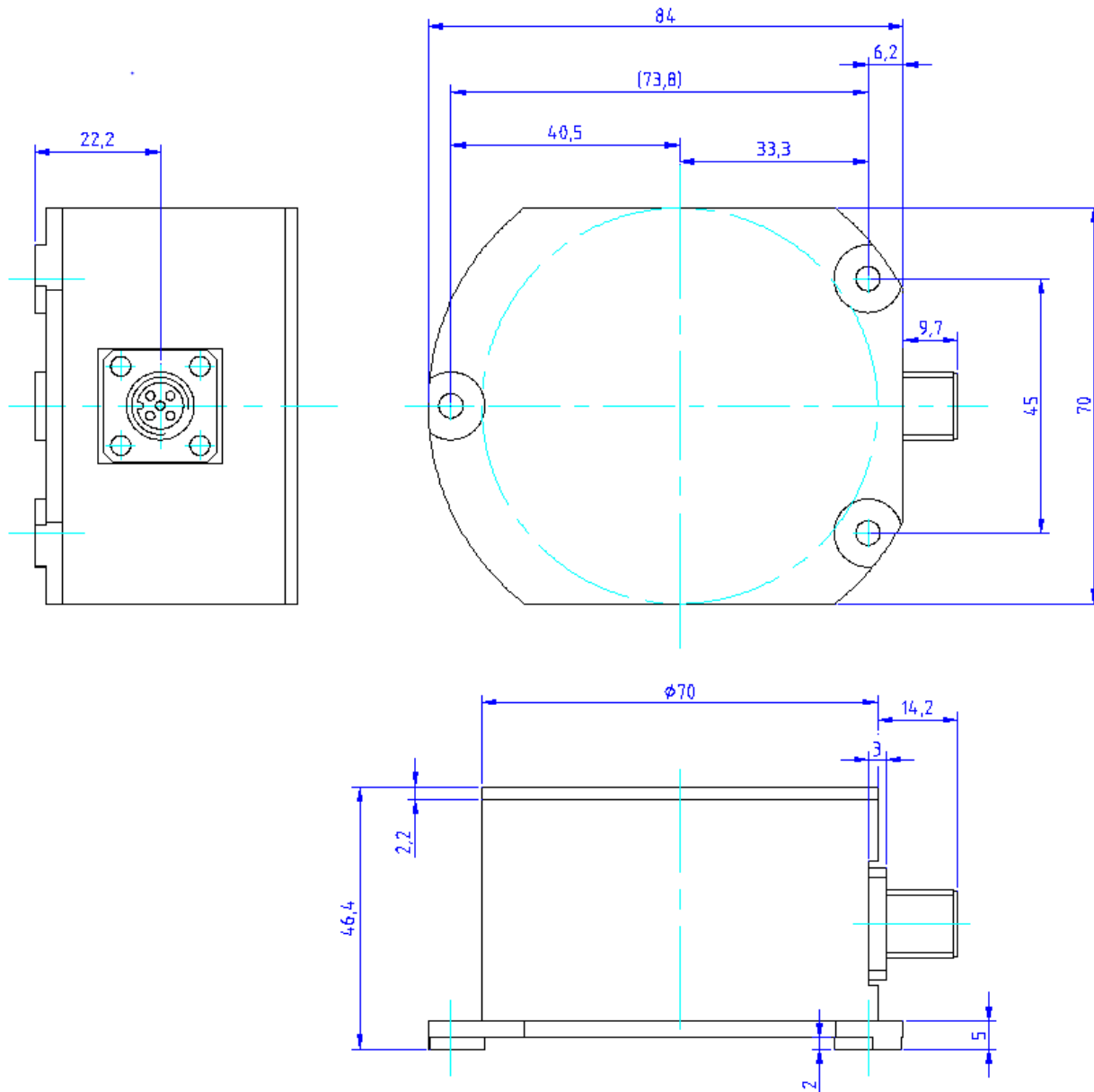

D-Series Inclinometer

PINNING - UNIT WITH RS 232 INTERFACE AND ANALOGUE OUTPUT

Pin	Name	Description	Type	Color schema ⁽¹⁾
1	+Ub	positive power supply +10...+30VDC	supply	white
2	RxD	Rx serial signal RS 232	input	brown
3	TxD	Tx serial signal RS232	output	green
4	GND	negative power supply, ground	supply	yellow
5	XOut	X-axis output	output	grey
6	SGND	signal ground	supply	pink
7	YOut	Y- axis output	output	blue
8	NC	NC	nc	nc

(1) by using a Measurement Specialties cable

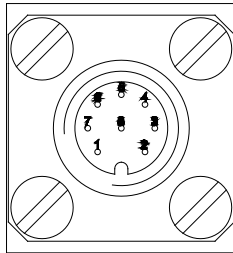

Front view of housing
connector inclinometer

For more details please use the product specification / application
note / instruction manual.

PINNING – UNIT WITH CANOPEN INTERFACE

Pin	Name	Description	Type	Color schema ⁽¹⁾
1	+Ub	positive power supply +10...+30VDC	supply	white
2	NC	nc	nc	brown
3	NC	nc	nc	green
4	GND	negative power supply, ground	supply	yellow
5	CANout	CAN Low	output	grey
6	CANgnd	CAN Ground	supply	pink
7	CANout	CAN High	output	blue
8	NC	nc	nc	nc

(1) by using a Measurement Specialties cable

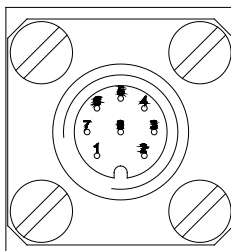

Front view of housing
connector inclinometer

For more details please use the product specification / application
note / instruction manual.

D-Series Inclinometer

ORDERING INFORMATION

PART NUMBERING	UNIT	SHORT DESCRIPTION
G-NSDMG-015	NS-5/DMG2-U	Range +/-5°, Vcc 10...30VDC, output RS232, voltage
G-NSDMG-017	NS-5/DMG2-I	Range +/-5°, Vcc 10...30VDC, output RS232, current
G-NSDMG-014	NS-5/DMG2-PWM	Range +/-5°, Vcc 10...30VDC, output RS232, PWM
G-NSDMG-016	NS-5/DMG2-S	Range +/-5°, Vcc 10...30VDC, output RS232, switch
G-NSDMG-030	NS-5/DMG2-CXD	Range +/-5°, Vcc 10...30VDC, output CANopen
G-NSDMG-019	NS-15/DMG2-U	Range +/-15°, Vcc 10...30VDC, output RS232, voltage
G-NSDMG-021	NS-15/DMG2-I	Range +/-15°, Vcc 10...30VDC, output RS232, current
G-NSDMG-018	NS-15/DMG2-PWM	Range +/-15°, Vcc 10...30VDC, output RS232, PWM
G-NSDMG-020	NS-15/DMG2-S	Range +/-15°, Vcc 10...30VDC, output RS232, switch
G-NSDMG-031	NS-15/DMG2-CXG	Range +/-15°, Vcc 10...30VDC, output CANopen
G-NSDMG-023	NS-30/DMG2-U	Range +/-30°, Vcc 10...30VDC, output RS232, voltage
G-NSDMG-025	NS-30/DMG2-I	Range +/-30°, Vcc 10...30VDC, output RS232, current
G-NSDMG-022	NS-30/DMG2-PWM	Range +/-30°, Vcc 10...30VDC, output RS232, PWM
G-NSDMG-024	NS-30/DMG2-S	Range +/-30°, Vcc 10...30VDC, output RS232, switch
G-NSDMG-032	NS-30/DMG2-CXN	Range +/-30°, Vcc 10...30VDC, output CANopen

Accessories

G-NSMIS-036	Connector	Connector, straight, 713-series
G-NSMIS-013	Connector	Connector, angle 90°, 713-series
G-NSMIS-008	Connection	2 m cable, straight connector 763-series
G-NSMIS-009	Connection	2 m cable, angle 90° connector 763-series

Other cable length on request

NORTH AMERICA	EUROPE	ASIA
Measurement Specialties, Inc. 1000 Lucas Way Hampton, VA 23666 United States Phone: +1-800-745-8008 Fax: +1-757-766-4297 Email: sales@meas-spec.com Web: www.meas-spec.com	MEAS Deutschland GmbH Hauert 13 D-44227 Dortmund Germany Phone: +49-(0)231-9740-0 Fax: +49-(0)231-9740-20 Email: info.de@meas-spec.com Web: www.meas-spec.com	Measurement Specialties China Ltd. No. 26, Langshan Road High-tech Park (North) Nanshan District, Shenzhen 518057 China Phone: +86-755-33305088 Fax: +86-755-33305099 Email: info.cn@meas-spec.com Web: www.meas-spec.com

The information in this sheet has been carefully reviewed and is believed to be accurate; however, no responsibility is assumed for inaccuracies. Furthermore, this information does not convey to the purchaser of such devices any license under the patent rights to the manufacturer. Measurement Specialties, Inc. reserves the right to make changes without further notice to any product herein. Measurement Specialties, Inc. makes no warranty, representation or guarantee regarding the suitability of its product for any particular purpose, nor does Measurement Specialties, Inc. assume any liability arising out of the application or use of any product or circuit and specifically disclaims any and all liability, including without limitation consequential or incidental damages. Typical parameters can and do vary in different applications. All operating parameters must be validated for each customer application by customer's technical experts. Measurement Specialties, Inc. does not convey any license under its patent rights nor the rights of others.