

P	LTR	DESCRIPTION	DATE	DWN	APVD
4		REVISED PER ECR-20-010947	04AUG2020	GK	AK

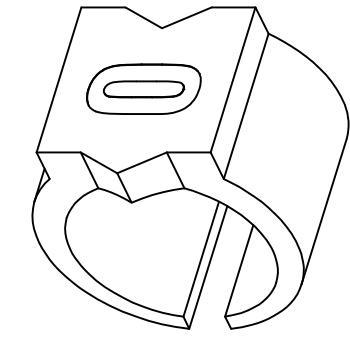

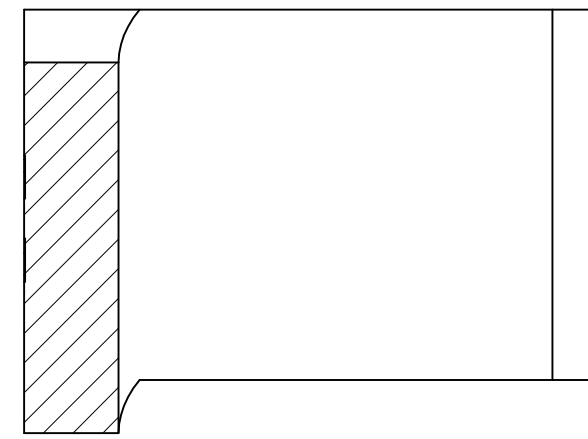
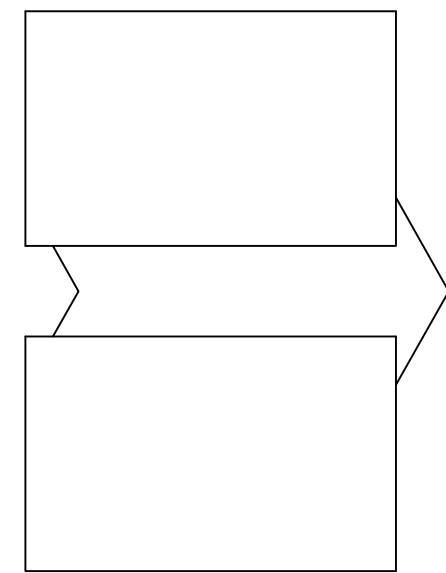
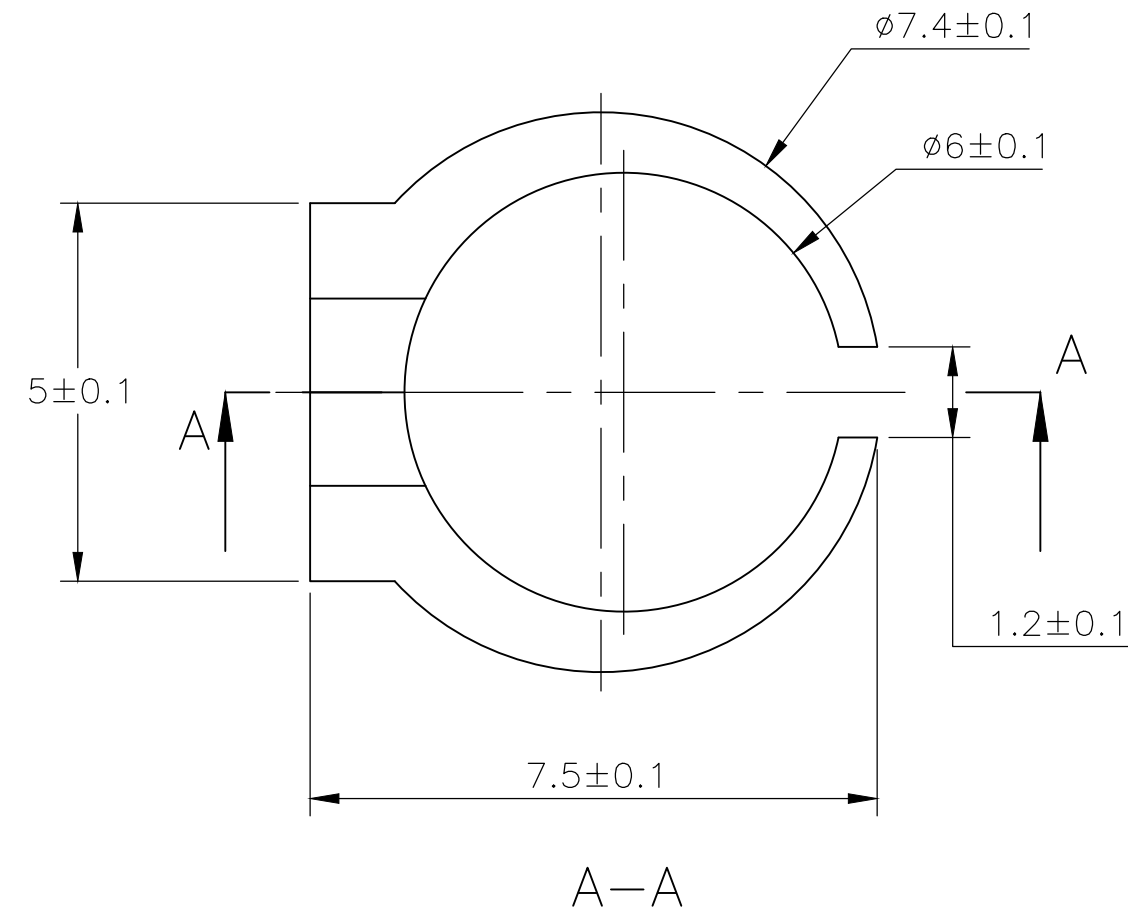
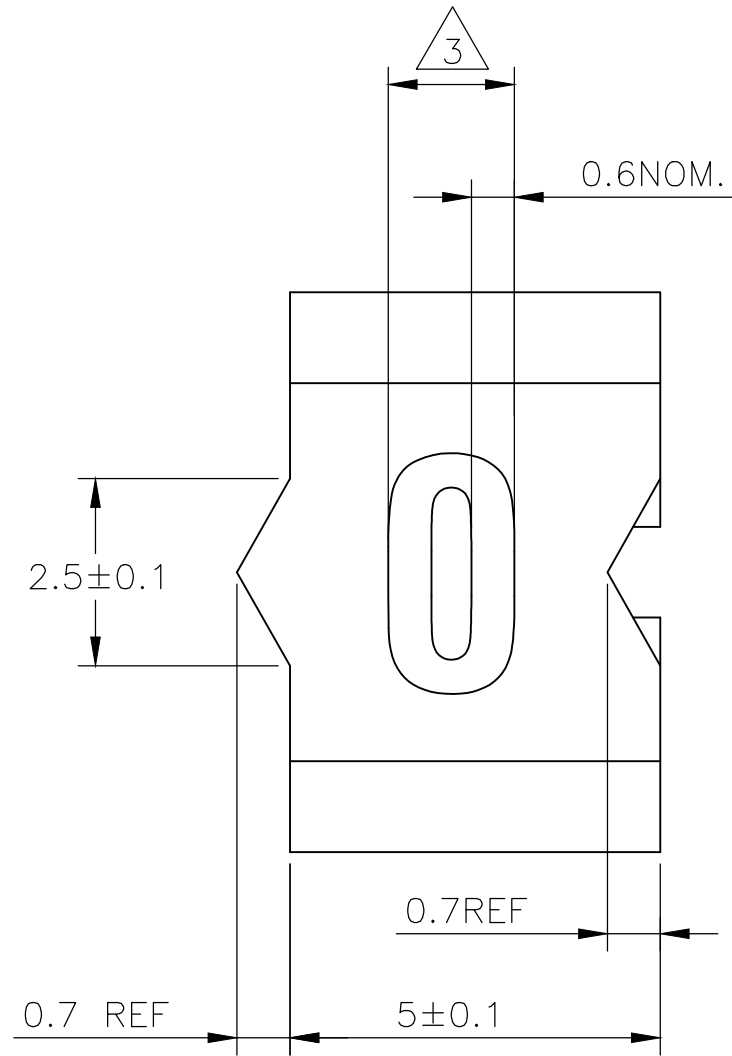

NOTES:

- 1 FOR PART NUMBER SEE SHEET 3 OF 3.
- 2 MARK SHOULD BE CENTRALLY POSITIONED ±0.1mm.
- 3 WIDTH OF MARK DEPENDS ON CHARACTER PRINTED

THIS DRAWING IS A CONTROLLED DOCUMENT.		DWN RAGHAVENDRA K 22MAR2013	TE Connectivity															
		CHK KEAN ALAN 22MAR2013																
		APVD MARIO APPELLO 22MAR2013	NAME SNAP-ON MARKER STB/STD SIZE 15 WITH APPLICATOR															
DIMENSIONS: mm		PRODUCT SPEC	-															
TOLERANCES UNLESS OTHERWISE SPECIFIED:		APPLICATION SPEC	-															
<table border="0"> <tr><td>0 PLC</td><td>± -</td></tr> <tr><td>1 PLC</td><td>± -</td></tr> <tr><td>2 PLC</td><td>± -</td></tr> <tr><td>3 PLC</td><td>± -</td></tr> <tr><td>4 PLC</td><td>± -</td></tr> <tr><td>ANGLES</td><td>± -</td></tr> </table>		0 PLC	± -	1 PLC	± -	2 PLC	± -	3 PLC	± -	4 PLC	± -	ANGLES	± -	WEIGHT	SIZE	CAGE CODE	DRAWING NO	RESTRICTED TO
0 PLC	± -																	
1 PLC	± -																	
2 PLC	± -																	
3 PLC	± -																	
4 PLC	± -																	
ANGLES	± -																	
MATERIAL		-	A3	C2290	C-7-1768045-4	-												
FINISH		-	CUSTOMER DRAWING		SCALE	SHEET												
		-			NTS	1 OF 3												
		-				REV 4												

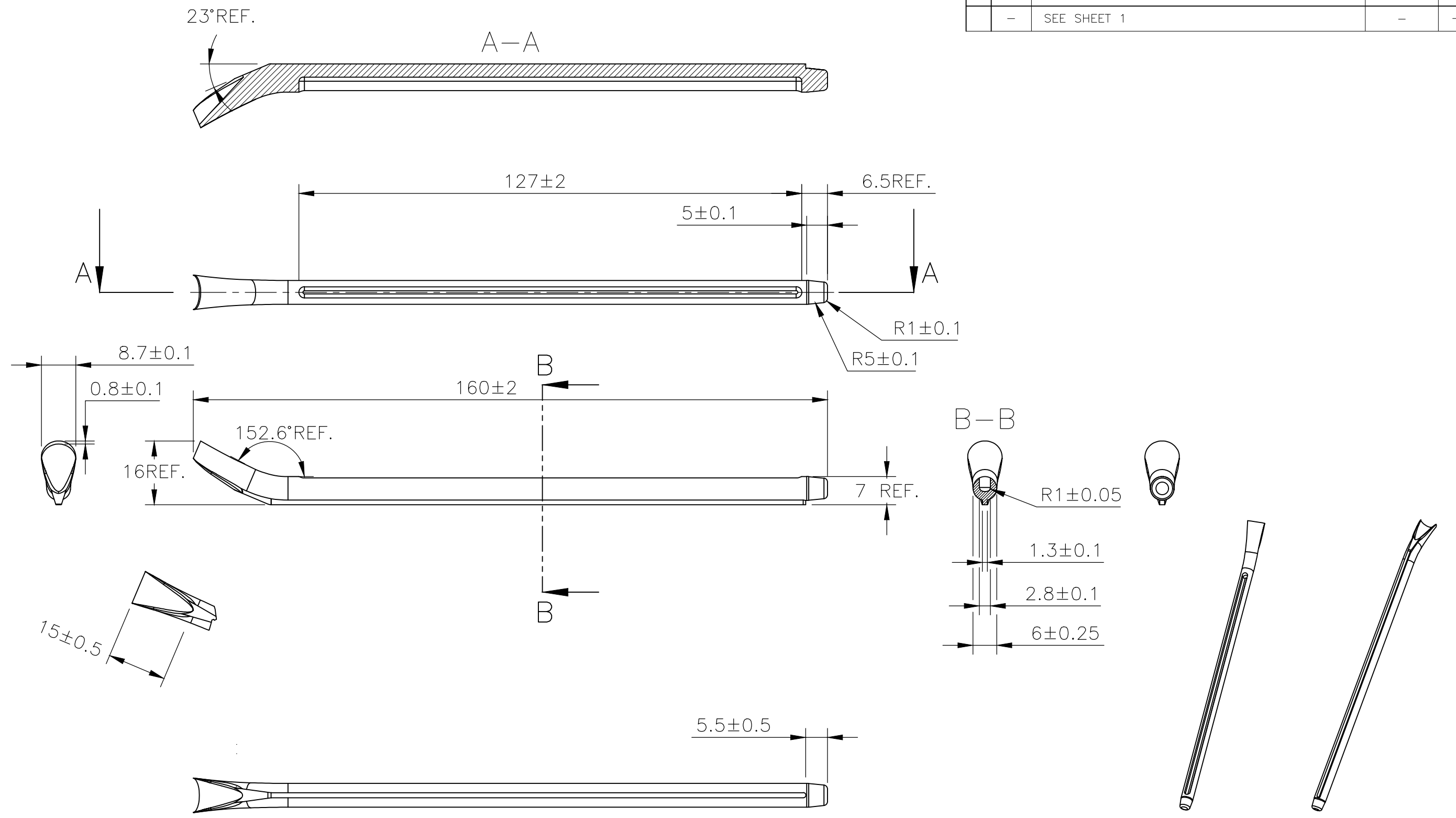
REVISIONS					
P	LTR	DESCRIPTION	DATE	DWN	APVD
-	-	SEE SHEET 1	-	-	-



THIS DRAWING IS A CONTROLLED DOCUMENT.		DWN RAGHAVENDRA K 22MAR2013	 TE Connectivity				
DIMENSIONS: mm		CHK KEAN ALAN 22MAR2013					
TOLERANCES UNLESS OTHERWISE SPECIFIED:		APVD MARIO APPELLO 22MAR2013	NAME SNAP-ON MARKER STB/STD SIZE 15 WITH APPLICATOR				
<ul style="list-style-type: none"> <li>0 PLC ± -</li> <li>1 PLC ± -</li> <li>2 PLC ± -</li> <li>3 PLC ± -</li> <li>4 PLC ± -</li> <li>ANGLES ± -</li> </ul>		PRODUCT SPEC -	APPLICATION SPEC -				
MATERIAL -		FINISH -	WEIGHT -	SIZE A3	CAGE CODE C2290	DRAWING NO C-7-1768045-4	RESTRICTED TO -
CUSTOMER DRAWING				SCALE NTS	SHEET 2 OF 3	REV 4	

REVISIONS

P	LTR	DESCRIPTION	DATE	DWN	APVD
	-	SEE SHEET 1	-	-	-

DESCRIPTION	PART NO.
STB15-0-0	6-1768039-0
STB15-1-1	6-1768039-1
STB15-1-2	2-1768413-1
STB15-1-3	9-1768412-3
STB15-1-5	6-1768039-2
STB15-2-2	6-1768039-4
STB15-2-5	6-1768039-5
STB15-3-2	2-1768413-2
STB15-3-3	6-1768039-7
STB15-4-2	2-1768413-3
STB15-5-2	2-1768413-4
STB15-5-5	7-1768039-0
STB15-6-6	7-1768039-2
STB15-7-7	7-1768039-3
STB15-8-8	7-1768039-6
STB15-A-3	7-1768039-7
STB15-A-5	7-1768039-8
STB15-BLANK-0	8-1768039-0
STB15-BLANK-1	8-1768039-1
STB15-BLANK-2	8-1768039-2
STB15-BLANK-3	8-1768039-3
STB15-BLANK-5	8-1768039-4
STB15-BLANK-6	8-1768039-5
STB15-BLANK-7	8-1768039-6
STB15-BLANK-8	8-1768039-7
STB15-F-6	8-1768039-9
STB15-H-2	9-1768039-0
STB15-H-5	7-1768418-2
STB15-L-5	9-1768039-2
STB15-R-0	9-1768039-6
STB15-R-5	9-1768039-8
STB15-S-5	7-1768418-3
STB15-0-2	2-1768413-0
STB15-6-2	2-1768413-5
STB15-7-2	2-1768413-6
STB15-9-2	2-1768413-8
STB15-B-5	7-1768039-9
STD15W-AC	5-1768045-6

DESCRIPTION	PART NO.
STB15-T-6	1768040-1
STB15-V-6	1768040-3
STD15-APPLICATOR	5-1768045-4
STD15W-0	5-1768045-5
STD15W-1	916500-000
STD15W-2	631526-000
STD15W-3	883382-000
STD15W-4	924992-000
STD15W-5	381396-000
STD15W-6	545292-000
STD15W-7	360170-000
STD15W-8	075056-000
STD15W-9	054712-000
STD15W-A	755008-000
<del>STD15W-A-LC</del>	<del>5-1768045-7</del>
STD15W-B	802902-000
STD15W-BLANK	5-1768045-8
STD15W-C	838714-000
STD15W-D	629606-000
<del>STD15W-D-LC</del>	<del>6-1768045-0</del>
STD15W-DOT	6-1768045-1
STD15W-E	133110-000
STD15W-EARTH	6-1768045-2
STD15W-F	537002-000
STD15W-G	685362-000
STD15W-H	863976-000
<del>STD15W-H-LC</del>	<del>6-1768045-2</del>
STD15W-I	913588-000
STD15W-J	344640-000
STD15W-K	501372-000
STD15W-L	002648-000
STD15W-COLON	126530-000

DESCRIPTION	PART NO.
STD15W-M	347828-000
STD15W-MINUS	6-1768045-9
STD15W-N	612672-000
STD15W-P	388482-000
STD15W-PLUS	7-1768045-2
STD15W-Q	621494-000
STD15W-R	325234-000
STD15W-S	544426-000
STD15W-SLASH	857128-000
STD15W-T	845482-000
STD15W-U	126270-000
STD15W-V	907764-000
STD15W-W	071812-000
STD15W-X	362816-000
STD15W-Y	578440-000
STD15W-Z	063698-000
STD15Y-0	7-1768045-4
STD15Y-1	7-1768045-5
STD15Y-2	7-1768045-6
STD15Y-3	7-1768045-7
STD15Y-4	7-1768045-8
STD15Y-5	7-1768045-9
STD15Y-6	8-1768045-0
STD15Y-7	8-1768045-1
STD15Y-8	8-1768045-2
STD15Y-9	8-1768045-3
STD15Y-A	8-1768045-4
STD15Y-B	8-1768045-7
STD15Y-BLANK	8-1768045-8
STD15Y-C	9-1768045-0

DESCRIPTION	PART NO.
STD15Y-COLON	9-1768045-1
STD15Y-D	9-1768045-2
STD15Y-DOT	9-1768045-4
STD15Y-E	9-1768045-5
STD15Y-EARTH	9-1768045-6
STD15Y-F	9-1768045-8
STD15Y-G	1768046-1
STD15Y-H	1768046-3
STD15Y-I	1768046-5
STD15Y-J	1768046-6
STD15Y-K	1768046-7
STD15Y-L	1768046-9
STD15Y-M	1-1768046-1
STD15Y-MINUS	1-1768046-2
STD15Y-N	1-1768046-4
STD15Y-P	1-1768046-6
STD15Y-PLUS	1-1768046-7
STD15Y-Q	1-1768046-8
STD15Y-R	1-1768046-9
STD15Y-S	2-1768046-1
STD15Y-SLASH	2-1768046-2
STD15Y-T	2-1768046-3
STD15Y-U	2-1768046-4
STD15Y-V	2-1768046-5
STD15Y-W	2-1768046-6
STD15Y-X	2-1768046-7
STD15Y-Y	2-1768046-8
STD15Y-Z	2-1768046-9
STD15Y-AC	8-1768045-5

4

4

4

4 OBSOLETE PART

THIS DRAWING IS A CONTROLLED DOCUMENT.

DIMENSIONS: mm	TOLERANCES UNLESS OTHERWISE SPECIFIED:
	0 PLC ± -
	1 PLC ± -
	2 PLC ± -
	3 PLC ± -
	4 PLC ± -
	ANGLES ± -
MATERIAL	FINISH
-	-

DWN	22MAR2013
RAGHAVENDRA K	
CHK	22MAR2013
KEAN ALAN	
APVD	22MAR2013
MARIO APPELLO	
PRODUCT SPEC	
APPLICATION SPEC	
WEIGHT	-
CUSTOMER DRAWING	

				TE Connectivity	
NAME				SNAP-ON MARKER STB/STD SIZE 15 WITH APPLICATOR	
SIZE	CAGE CODE	DRAWING NO	RESTRICTED TO		
A3	C2290	G-7-1768045-4	-		
SCALE			SHEET	REV	
NTS			3 OF 3	4	