

THIS DRAWING IS UNPUBLISHED. RELEASED FOR PUBLICATION  
 © COPYRIGHT - By - ALL RIGHTS RESERVED.

REVISIONS					
P	LTR	DESCRIPTION	DATE	DWN	APVD
	Y1	REVISED PER ECR-18-007177	4MAY2018	HX	WH

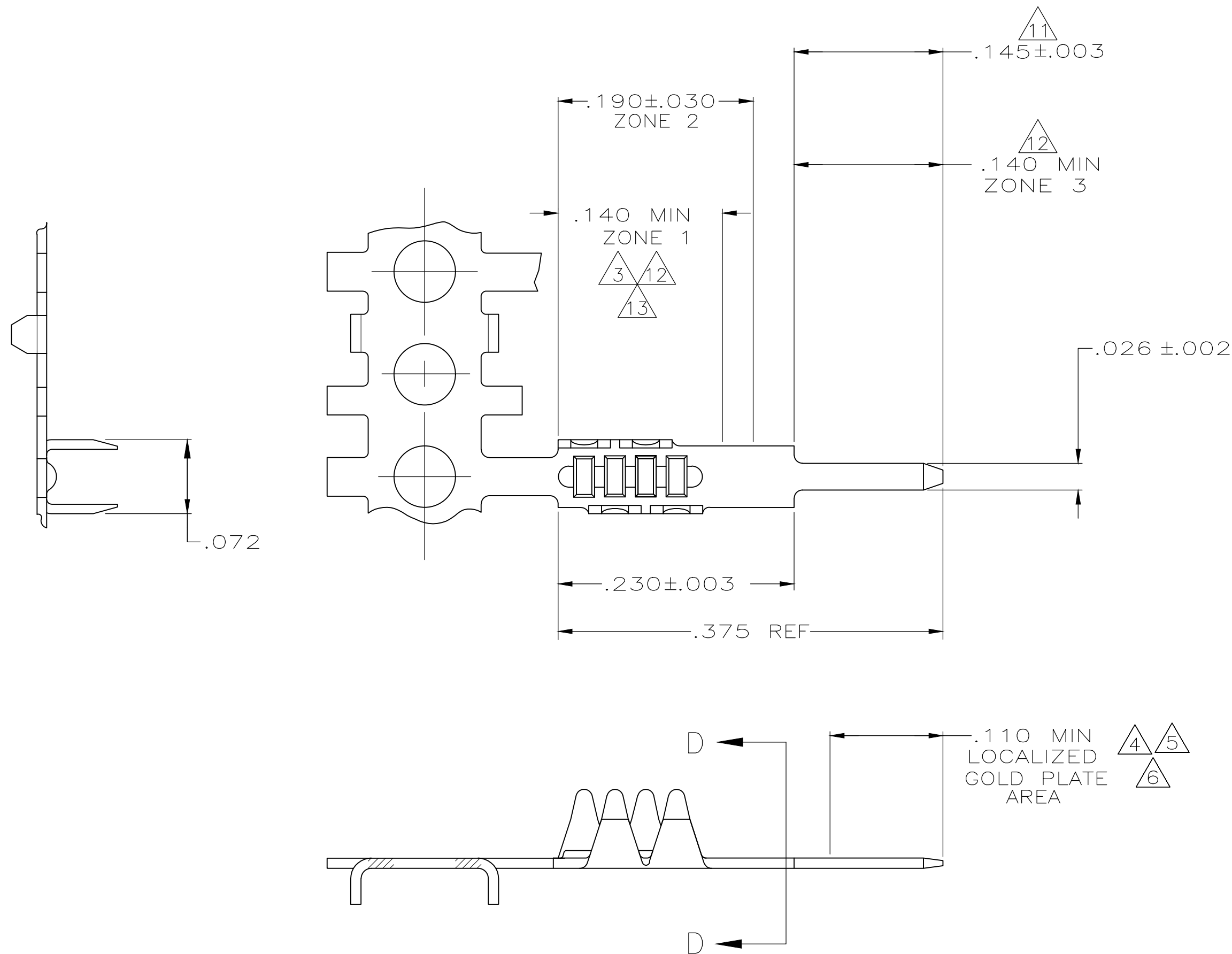

- 1 .000050 MIN THK NICKEL UNDERPLATE OVER ENTIRE CONTACT.
- 2 .000150 MIN BRIGHT TIN/LEAD OVER ENTIRE CONTACT.
- 3 .000100 MIN THK BRIGHT TIN/LEAD IN ZONE 1.
- 4 GOLD FLASH IN LOCALIZED GOLD PLATE AREA.
- 5 .000015 MIN GOLD IN LOCALIZED GOLD PLATE AREA
- 6 .000030 MIN GOLD IN LOCALIZED GOLD PLATE AREA
- 7. TO BE APPLIED PER AMP APPLICATION SPEC 114-16015.
- 8. RECOMMENDED HOLE SIZE IS .031-.035 DIA.
- 9 FOR SOLDERABILITY SEE AMP PRODUCT SPEC 108-9024.
- 10 .000150 MIN TIN-LEAD IN ZONE 2.
- 11 AREA TO BE UNPLATED (-9 ONLY).
- 12 GOLD FLASH IN ZONE 1. .000150 MIN TIN IN ZONE 3.
- 13 GOLD FLASH IN ZONE 1.
- 14 GOLD PLATING MAY OR MAY NOT BE PRESENT ON THE BOTTOM OF THE CRIMP BARREL IN THIS AREA.
- 15 .000150 MIN TIN ENTIRE CONTACT.

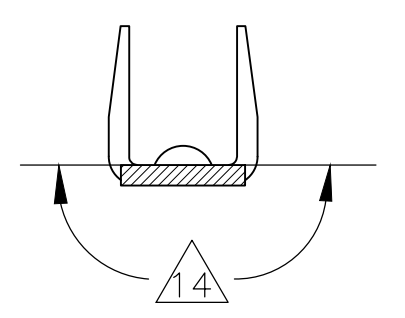
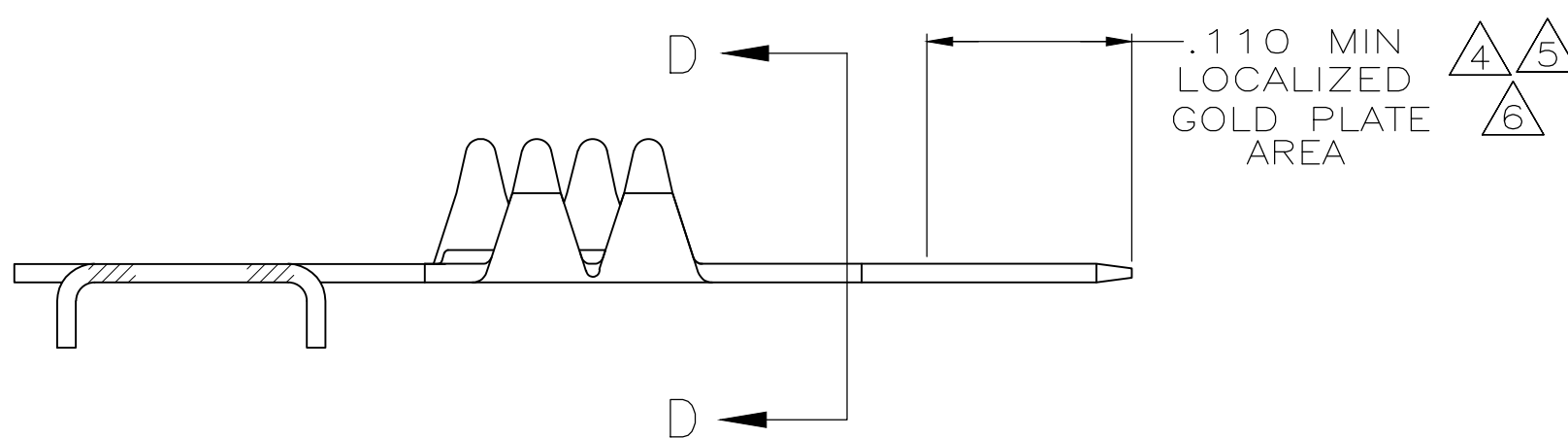

SECTION D-D

	1 15 9	2-88997-7
	1 6 13 14	1-88997-4
	1 5 13 14	1-88997-3
	1 9 12 14	1-88997-2
OBSOLETE	10 11	88997-9
	1 3 6	88997-5
	1 3 5	88997-4
SUPERSEDED BY 88997-5	1 3 4	88997-3
	1 2 9	88997-2
	FINISH	PART NO

THIS DRAWING IS A CONTROLLED DOCUMENT.		DWN B. MCMASTER 10MAR04	TE Connectivity	
DIMENSIONS: INCHES		CHK S. BOLASH 10MAR04		
TOLERANCES UNLESS OTHERWISE SPECIFIED:		APVD M. WALMSLEY 10MAR04	NAME CONTACT, SOLDER TAB, FFC, .100 ̢	
0 PLC ± -		PRODUCT SPEC 108-9024	SIZE A2	CAGE CODE 00779
1 PLC ± -		APPLICATION SPEC 114-16015	DRAWING NO C-88997	RESTRICTED TO -
2 PLC ± -		WEIGHT 0.000000	SCALE 10:1	SHEET 1 OF 1
3 PLC ± .005		CUSTOMER DRAWING	REV Y1	
4 PLC ± -				
ANGLES ± -				
FINISH SEE TABLE				