

PD57/60/86-x-1260 Hardware Manual

Hardware Version V1.10 | Document Revision V1.31 • 2021-AUG-18

The PANdrive™ PD57-1-1260, PD57-2-1260, PD60-3-1260, PD60-4-1260, and PD86-3-1260 are powerful and compact full mechatronic solutions including NEMA23 / 57mm or NEMA24 / 60mm or NEMA34 / 86mm flange size stepper motors, the TCM-1260 controller / driver electronics and TRINAMIC™ sensOstep™ encoder for step-loss detection.

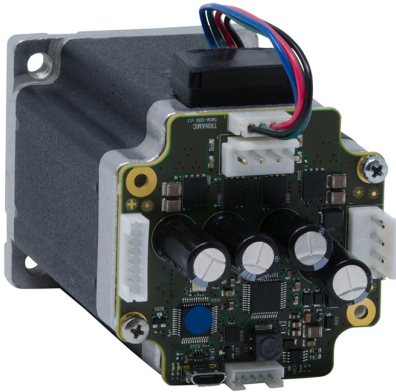

Features

- Stepper Motor NEMA23 / 57mm or NEMA24 / 60mm or NEMA34 / 86mm
- 0.55 - 7.0Nm
- with controller / driver
- Linear and sixPoint™ ramps
- +24V and +48V DC supply voltage
- Up to 5.5A RMS motor current
- RS485, CAN & USB interface
- integrated sensOstep encoder and support for external encoder
- S/D interface
- multi-purpose inputs and outputs

Applications

- Laboratory Automation
- Manufacturing
- Semiconductor Handling
- Robotics
- Factory Automation
- Test & Measurement
- Life Science
- Biotechnology
- Liquid Handling

Simplified Block Diagram

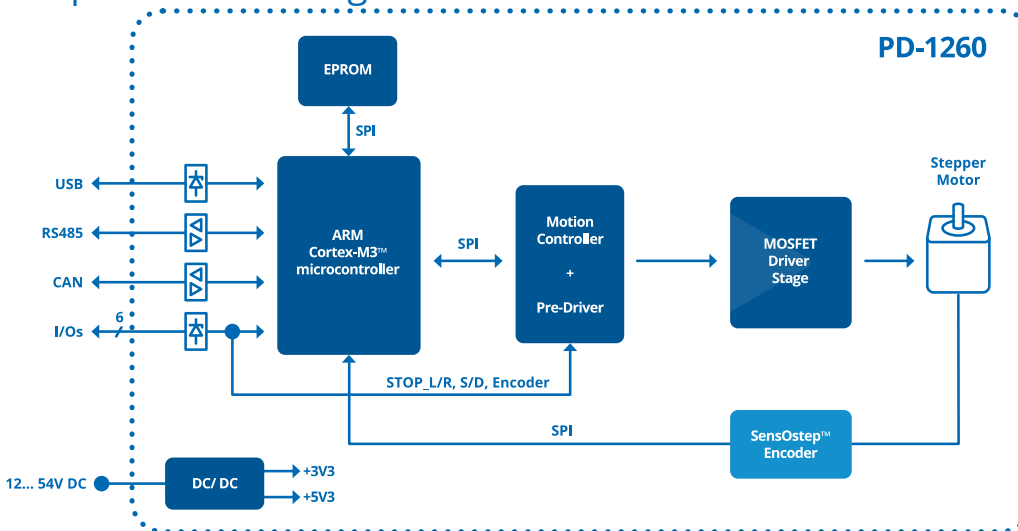

©2021 TRINAMIC Motion Control GmbH & Co. KG, Hamburg, Germany
 Terms of delivery and rights to technical change reserved.
 Download newest version at: www.trinamic.com



Read entire documentation.

Contents

1	Features	4
2	Order Codes	6
3	Mechanical and Electrical Interfacing	9
3.1	PD57-1-1260 and PD57-2-1260 Dimensions	9
3.2	PD60-3-1260 and PD60-4-2-1260 Dimensions	10
3.3	PD86-3-1260 Dimensions	11
3.4	Stepper motor	12
3.5	Integrated sensOstep™ encoder	13
4	Connectors	14
4.1	Power Supply Input Connector	15
4.2	Motor Connector	16
4.3	RS485 + CAN Connector	16
4.4	USB Connector	17
4.5	I/O Connector	17
5	On-Board LEDs	18
6	Reset to Factory Defaults	19
7	I/Os	20
7.1	Analog input IN0	20
7.2	Digital inputs IN1 and IN2	20
7.3	HOME/STOP_L/STOP_R switch inputs	21
7.4	External incremental encoder input	21
7.5	Step/Direction inputs	22
8	Communication	23
8.1	RS485	23
8.2	CAN	24
9	Motor driver current	26
10	Torque curves	28
10.1	PD57-1-1260 Torque Curve	28
10.2	PD57-2-1260 Torque Curve	29
10.3	PD60-3-1260 Torque Curve	30
10.4	PD60-4-1260 Torque Curve	31
10.5	PD86-3-1260 Torque Curve	32
11	Functional Description	33
12	Operational Ratings and Characteristics	34
13	Abbreviations used in this Manual	36
14	Figures Index	37
15	Tables Index	38
16	Supplemental Directives	39
16.1	Producer Information	39



16.2 Copyright	39
16.3 Trademark Designations and Symbols	39
16.4 Target User	39
16.5 Disclaimer: Life Support Systems	39
16.6 Disclaimer: Intended Use	39
16.7 Collateral Documents & Tools	40
17 Revision History	41
17.1 Hardware Revision	41
17.2 Document Revision	41



1 Features

The PANdrive™ PD57-1-1260, PD57-2-1260, PD60-3-1260, PD60-4-1260, and PD86-3-1260 are powerful and compact full mechatronic solutions including NEMA23 / 57mm or NEMA24 / 60mm or NEMA34 / 86mm flange size stepper motors, the TMCM-1260 controller / driver electronics and TRINAMIC™ sensOstep™ encoder for step-loss detection. The five PANdrives include stepper motors with different lengths and different holding torques (PD57-1-1260: 0.55Nm, PD57-2-1260: 1.01Nm, PD60-3-1260: 2.1Nm and PD60-4-1260: 3.1Nm and PD86-3-1260: 7.0Nm) but, same electronics and encoder setup. The PANdrives support both, stand-alone operation e.g. using the on-board I/Os together with the build-in TMCL scripting feature and remote operation using one of the available communication interfaces and even a mixture of both.

Motion Controller

- Motion profile calculation in real-time
- On the fly alteration of motor parameters (e.g. position, velocity, acceleration)
- Linear and unique sixPoint™ramp in hardware
- Encoder interface and Reference / Stop switch inputs

Driver

- Motor current: 5.5A RMS, 7.7A peak (programmable in software)
- Supply voltage: +24V and +48V DC (+12... +54V DC)
- 256 microsteps per fullstep
- spreadCycle™highly dynamic current control chopper
- stealthChop™for quiet operation and smooth motion
- programmable Step/Dir interface for driver-only applications with microstep interpolation

Encoder

- integrated sensOstep absolut position magnetic encoder (resolution: 1024 increments per rotation) for step-loss detection under all operating conditions and positioning supervision (accuracy: +/- 5 encoder steps)
- support for external A/B incremental encoder in addition / as an alternative for the integrated encoder
- programmable encoder scaling and support for motor stop on encoder deviation

Interfaces

- RS485 interface (up-to 1Mbit/s)
- CAN interface (up-to 1Mbit/s)
- USB 2.0 full speed (12Mbit/s) device interface (micro-USB connector)
- Step/Dir input (optically isolated)
- Left and Right STOP switch inputs (optically isolated, shared with Step/Dir inputs)
- 2 general purpose digital inputs
- Encoder input for incremental A/B encoder signals (shared with general purpose digital inputs)



- 1 analog input (0..10V nom. input range)
- HOME switch input (shared with analog input)

Mechanical data

- PD57-1-1260 size: 60mm x 60mm, length = 69mm (without mating connectors and motor axis)
- PD57-2-1260 size: 60mm x 60mm, length = 79mm (without mating connectors and motor axis)
- PD60-3-1260 size: 60mm x 60mm, length = 93mm (without mating connectors and motor axis)
- PD60-4-1260 size: 60mm x 60mm, length = 114mm (without mating connectors and motor axis)
- PD86-3-1260 size: 86mm x 86mm, length = 126mm (without mating connectors and motor axis)
- 4 mounting holes for M3 screws

Software

- TMCL™ remote (direct mode) and standalone operation (memory for up to 1024 TMCL™ commands), fully supported by TMCL-IDE (PC based integrated development environment). Please see PD57/60/86-x-1260 TMCL firmware manual for more details
- CANopen firmware with CANopen standard protocol stack for the CAN interface. Please see PD57/60/86-x-1260 CANopen firmware manual for more details.



2 Order Codes

The combination of motor and motor mounted controller/driver electronic is currently available with three different stepper motor series (NEMA23 / 57mm flange size or NEMA24 / 60mm flange size or NEMA34 / 86mm flange size) and five different stepper motors (different length and holding torque): The length of the PANdrives is specified without the length of the axis. For the overall length of the product please add ca. 24mm.

Order Code	Description	Size (LxWxH)
PD57-1-1260-TMCL	PANdrive™with NEMA23 stepper motor, 0.55Nm max., TCM-1260 electronics, 2.8A RMS, +48V, integrated sensOstep™ encoder, S/D input, ext. Encoder input, 1 analog input, 4 digital inputs, 1 OD output, CAN, RS485 and USB interfaces, TMCL firmware	60mm x 60mm x 69mm
PD57-2-1260-TMCL	PANdrive™with NEMA23 stepper motor, 1.01Nm max., TCM-1260 electronics, 2.8A RMS, +48V, integrated sensOstep™ encoder, S/D input, ext. Encoder input, 1 analog input, 4 digital inputs, 1 OD output, CAN, RS485 and USB interfaces, TMCL firmware	60mm x 60mm x 79mm
PD60-3-1260-TMCL	PANdrive™with NEMA24 stepper motor, 2.1Nm max., TCM-1260 electronics, 2.8A RMS, +48V, integrated sensOstep™ encoder, S/D input, ext. Encoder input, 1 analog input, 4 digital inputs, 1 OD output, CAN, RS485 and USB interfaces, TMCL firmware	60mm x 60mm x 93mm
PD60-4-1260-TMCL	PANdrive™with NEMA24 stepper motor, 3.1Nm max., TCM-1260 electronics, 2.8A RMS, +48V, integrated sensOstep™ encoder, S/D input, ext. Encoder input, 1 analog input, 4 digital inputs, 1 OD output, CAN, RS485 and USB interfaces, TMCL firmware	60mm x 60mm x 114mm
PD86-3-1260-TMCL	PANdrive™with NEMA34 stepper motor, 7.0Nm max., TCM-1260 electronics, 5.5A RMS, +48V, integrated sensOstep™ encoder, S/D input, ext. Encoder input, 1 analog input, 4 digital inputs, 1 OD output, CAN, RS485 and USB interfaces, TMCL firmware	86mm x 86mm x 126mm
PD57-1-1260-CANopen	PANdrive™with NEMA23 stepper motor, 0.55Nm max., TCM-1260 electronics, 2.8A RMS, +48V, integrated sensOstep™ encoder, S/D input, ext. Encoder input, 1 analog input, 4 digital inputs, 1 OD output, CAN, RS485 and USB interfaces, CANopen firmware	60mm x 60mm x 69mm



Order Code	Description	Size (LxWxH)
PD57-2-1260-CANopen	PANdrive™with NEMA23 stepper motor, 1.01Nm max., TCMC-1260 electronics, 2.8A RMS, +48V, integrated sensOstep™ encoder, S/D input, ext. Encoder input, 1 analog input, 4 digital inputs, 1 OD output, CAN, RS485 and USB interfaces, CANopen firmware	60mm x 60mm x 79mm
PD60-3-1260-CANopen	PANdrive™with NEMA24 stepper motor, 2.1Nm max., TCMC-1260 electronics, 2.8A RMS, +48V, integrated sensOstep™ encoder, S/D input, ext. Encoder input, 1 analog input, 4 digital inputs, 1 OD output, CAN, RS485 and USB interfaces, CANopen firmware	60mm x 60mm x 93mm
PD60-4-1260-CANopen	PANdrive™with NEMA24 stepper motor, 3.1Nm max., TCMC-1260 electronics, 2.8A RMS, +48V, integrated sensOstep™ encoder, S/D input, ext. Encoder input, 1 analog input, 4 digital inputs, 1 OD output, CAN, RS485 and USB interfaces, CANopen firmware	60mm x 60mm x 114mm
PD86-3-1260-CANopen	PANdrive™with NEMA34 stepper motor, 7.0Nm max., TCMC-1260 electronics, 5.5A RMS, +48V, integrated sensOstep™ encoder, S/D input, ext. Encoder input, 1 analog input, 4 digital inputs, 1 OD output, CAN, RS485 and USB interfaces, CANopen firmware	86mm x 86mm x 126mm

Table 1: TCMC-1260 Order Code

A cable loom set is available for this module:

Order Code	Description
TCMC-1260-CABLE	<p>Cable loom for TCMC-1260:</p> <ul style="list-style-type: none"> • 1x cable loom for power supply connector (cable length 200mm, 4pin JST VH connector at one end, open wires at other end) • 1x cable loom for RS485 + CAN connector (cable length 200mm, 5pin JST PH connector at one end, open wires at other end) • 1x cable loom for motor connector (cable length 200mm, 4pin JST EH connector at one end, open wires at other end) • 1x cable loom for (alternate high power) motor connector (cable length 200mm, 4pin JST VH connector at one end, open wires at other end) • 1x cable loom for I/O connector (cable length 200mm, 8pin JST PH connector at one end, open wires at other end) • 1x Micro-USB cable

Table 2: TCMC-1260 Cable Loom



The TMCM-1260 controller/driver electronics is also available separately. Please refer to TMCM-1260 hardware manual for further details.



3 Mechanical and Electrical Interfacing

3.1 PD57-1-1260 and PD57-2-1260 Dimensions

The PD57-1-1260 and PD57-2-1260 include one NEMA23 / 57mm stepper motors with 2.8A RMS rated coil current with the same TCMC-1260 controller / driver electronics mounted on its backside and integrated sensOstep™ encoder. The PD57-1-1260 uses the QSH5718-41-28-055 stepper motor with 0.55Nm holding torque and the PD57-2-1260 uses the QSH5718-51-28-101 stepper motor with 1.01Nm holding torque. Please see also stepper motor manuals and TCMC-1260 hardware and firmware manuals for more details.

NOTICE

Note: In order to make proper use of the integrated sensOstep™ encoder (the sensor IC is placed on the bottom of the pcb) the TCMC-1260 electronics should not be removed/moved relative to the motor. In case the integrated encoder feature is not used, the electronics may be moved or even removed from the motor and placed somewhere else according to application requirements.

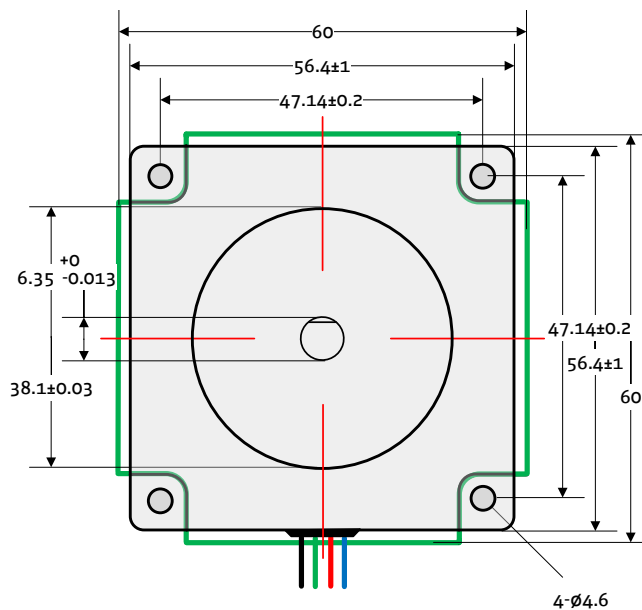
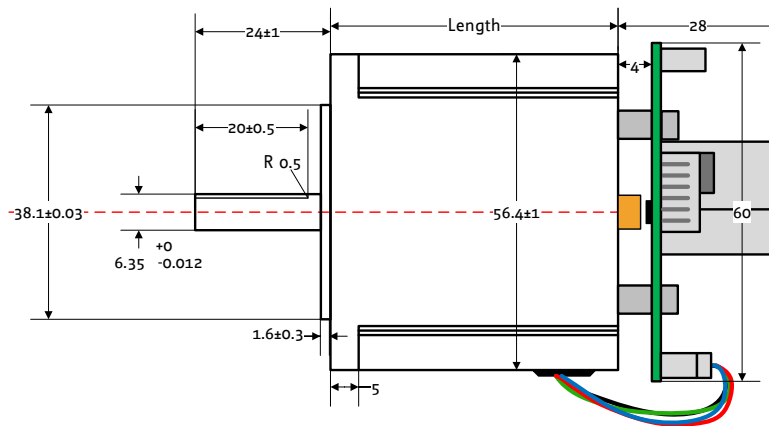

Length of the stepper motor “body” itself is 41mm for the PD57-1-1260 and 51mm for the PD57-2-1260.

3.2 PD60-3-1260 and PD60-4-2-1260 Dimensions

The PD60-3-1260 and PD60-4-1260 include one NEMA24 / 60mm stepper motors with 2.8A RMS rated coil current with the same TCMC-1260 controller / driver electronics mounted on its backside and integrated sensOstep™ encoder. The PD60-3-1260 uses the QSH6018-65-28-210 stepper motor with 2.1Nm holding torque and the PD60-4-1260 uses the QSH6018-86-28-310 stepper motor with 3.1Nm holding torque. Please see also stepper motor manuals and TCMC-1260 hardware and firmware manuals for more details.

NOTICE

Note: In order to make proper use of the integrated sensOstep™ encoder (the sensor IC is placed on the bottom of the pcb) the TCMC-1260 electronics should not be removed/moved relative to the motor. In case the integrated encoder feature is not used, the electronics may be moved or even removed from the motor and placed somewhere else according to application requirements.

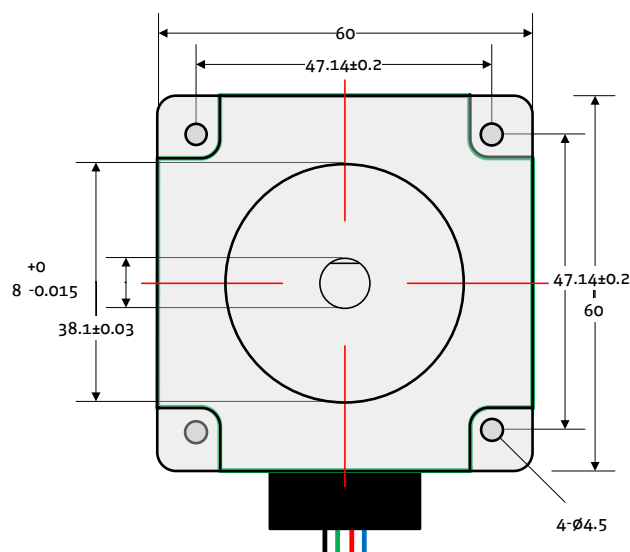
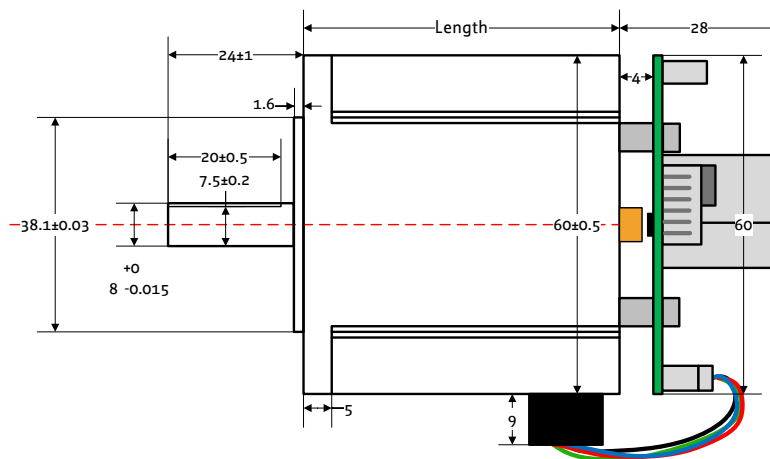

Length of the stepper motor “body” itself is 65mm for the PD60-3-1260 and 86mm for the PD60-4-1260.

3.3 PD86-3-1260 Dimensions

The PD86-3-1260 includes a NEMA34 / 86mm stepper motors with 5.5A RMS rated coil current with the TCMC-1260 controller / driver electronics mounted on its backside and integrated sensOstep™ encoder. The PD86-3-1260 uses the QSH8618-96-55-700 stepper motor with 7.0Nm holding torque. Please see also stepper motor manuals and TCMC-1260 hardware and firmware manuals for more details.

NOTICE **Note:** In order to make proper use of the integrated sensOstep™ encoder (the sensor IC is placed on the bottom of the pcb) the TCMC-1260 electronics should not be removed/moved relative to the motor. In case the integrated encoder feature is not used, the electronics may be moved or even removed from the motor and placed somewhere else according to application requirements.

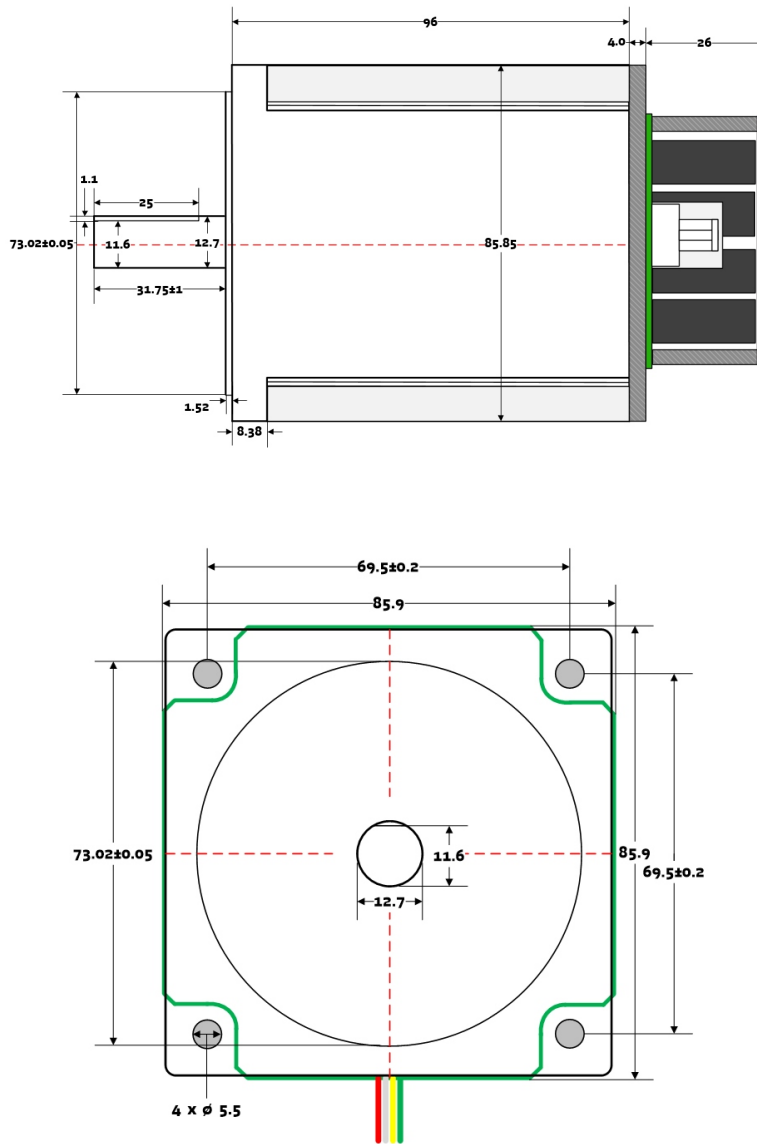

Length of the stepper motor “body” itself is 96mm for the PD86-3-1260.

3.4 Stepper motor

Main characteristics of the five different motors available as part of the PD57-x-1260 and PD60-x-1260 and PD86-3-1260 PANdrive™:

Specifications	Unit	PD57-1-1260	PD57-2-...	PD60-3-...	PD60-4-...	PD86-3-...
Step angle	°	1.8	1.8	1.8	1.8	1.8
Step angle accuracy	%	+/-5	+/-5	+/-5	+/-5	+/-5
Ambient temperature	°C	-20...+50	-20...+50	-20...+50	-20...+50	-20...+50
Max. motor temperature	°C	80	80	80	80	80
Shaft radial play (450g load)	mm	0.02	0.02	0.02	0.02	0.02
Shaft axial play (450g load)	mm	0.08	0.08	0.08	0.08	0.08
Max radial force (20mm from front flange)	N	57	57	57	57	220
Max axial force	N	15	15	15	15	60
Rated voltage	V	2.0	2.3	3.36	4.17	2.57
Rated phase current	A	2.8	2.8	2.8	2.8	5.5
Phase resistance at 20°C	Ω	0.7	0.83	1.2	1.5	0.45
Phase inductance (typ.)	mH	1.4	2.2	4.6	6.8	4.5
Holding torque	Nm	0.55	1.01	2.1	3.1	7.0
Insulation class		B	B	B	B	B
Rotor inertia	g cm ²	120	275	570	840	2700
Weight	kg	0.45	0.65	1.2	1.4	2.8

Table 3: NEMA23, NEMA24, and NEMA34 stepper motor technical data



3.5 Integrated sensOstep™ encoder

The PD57/60/86-x-1260 PANdrives offer integrated sensOstep™ encoders based on hall sensor technology. As the name "sensOstep™" already indicates intended use of this type of compact and highly integrated encoder is step loss detection of motor movements. As soon as the motor has been moved to a new location the position may be verified using this encoder feedback. In case the stepper motor has lost one or multiple steps during movement e.g. due to overload / any obstacle encountered during movement the motor axes will jump for at least one electrical period / 4 full steps. This can be detected using the integrated encoder. In addition, step losses may be already detected during motor movements using the "deviation" setting available as part of the TMCL firmware (see PD57/60/86-x-1260 / TMCM-1240 firmware manual for more details).

While the encoder offers 10bit (1024 steps) resolution per motor revolution the absolute position information is less accurate and depends on the displacement of the hall sensor based encoder IC relative to the magnet and motor axis among other factors. Every PANdrive™ has been tested for maximum deviation of +/- 5 encoder steps (static performance) relative to commanded microstep target position during final tests after assembly at our factory. This will ensure more than adequate performance of the integrated sensOstep™ encoder for step loss detection during motor movements.

NOTICE

Do not disassemble PANdrive™ when using integrated encoder In order to make proper use of the integrated sensOstep™ encoder (the sensor IC is placed on the bottom center of the pcb) the TMCM-1260 electronics should not be removed/moved relative to the motor! Otherwise encoder performance might suffer / not work.

Note: In case the integrated encoder feature is not used, the TMCM-1260 electronics may be moved or even removed from the motor and placed somewhere else according to application requirements.

NOTICE

Keep the electronics free of (metal) particles! The integrated sensOstep™ encoder uses a magnet at the end of the motor axis in order to monitor position of the motor axis. ««««< HEAD The magnet naturally attracts especially tiny metal particles. These particles might be held on the top side of the PCB and even worse - start moving in accordance with the rotating magnetic field ===== The magnet naturally attracts especially tiny metal particles. These particles might be held on the top side of the PCB and - even worse - start moving in accordance with the rotating magnetic field »»»»> 364467ec9aaa611190ef248caabb852f276fb5e4 as soon as the motor starts moving. This might lead to shorts of electronic contacts / wires on the board and totally erratic behavior of the module! Use compressed air for cleaning the module if necessary (especially in prototype setups).

In order to prevent shorts and better protect the electronics the TMCM-1260 printed circuit board is coated after assembly of components.



4 Connectors

The PD57/60/86-x-1260 offers six connectors altogether. There is one power supply connector and two interface connectors - one with five pins for RS485 and CAN and a dedicated micro-USB connector. All other inputs and outputs are concentrated on one 8 pin connector. Furthermore, there is one connection for the stepper motor with four pins with a choice between two connectors with different size, pitch and current rating. For the line of PANdrives™ the smaller one is used and already connected to the attached motor.

NOTICE

Start with power supply OFF and do not connect or disconnect motor during operation! Motor cable and motor inductivity might lead to voltage spikes when the motor is (dis)connected while energized. These voltage spikes might exceed voltage limits of the driver MOSFETs and might permanently damage them. Therefore, always switch off / disconnect power supply or at least disable driver stage before connecting / disconnecting motor.

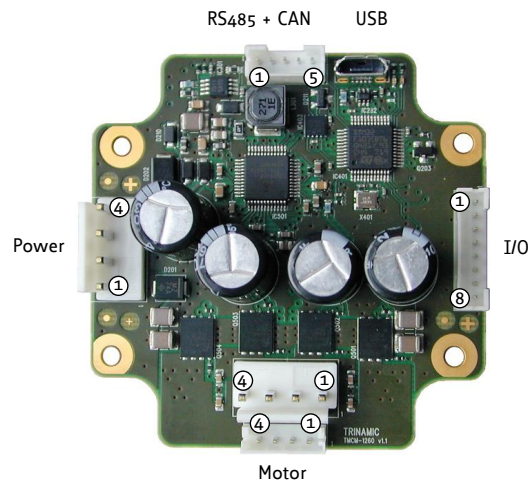

Figure 1: PD57/60/86-x-1260 connectors

Connector Types and Mating Connectors		
Connector	Connector type on-board	Mating connector type
Power	JST B4P-VH (JST VH series, 4pins, 3.96mm pitch)	Connector housing: JST VHR-4N Contacts: JST SVH-21T-P1.1 Wire: 0.83mm ² , AWG 18
Motor	JST JST B4P-VH (JST VH series, 4pins, 3.96mm pitch) or JST JST B4B-EH-A (JST EH series, 4pins, 2.5mm pitch)	Connector housing: JST VHR-4N Contacts: JST SVH-21T-P1.1 Wire: 0.83mm ² , AWG 18 or Connector housing: JST EHR-4 Contacts: JST SEH-001T-P0.6 Wire: 0.33mm ² , AWG 22
RS485+CAN	JST B5B-PH-K-S (JST PH series, 5pins, 2mm pitch)	Connector housing: JST PHR-5 Contacts: JST SPH-002T-P0.5S Wire: 0.22mm ² , AWG 24



Connector	Connector type on-board	Mating connector type
USB	USB-micro B female connector	USB-micro B male connector
I/O	JST B8B-PH-K-S (JST PH series, 8pins, 2mm pitch)	Connector housing: JST PHR-8 Contacts: JST SPH-002T-P0.5S Wire: 0.22mm ² , AWG 24

Table 4: Connector Types and Mating Connectors of the PD57/60/86-x-1260

4.1 Power Supply Input Connector

The PD57/60/86-x-1260 offers one 4pin JST VH series power supply input connector. In addition to main power supply input and related ground connection this connector offers a separate logic supply input with the option to keep the on-board logic alive while the driver stage is switched off. It is not necessary to connect the logic supply input in case separate supplies are not required as the main power supply input will always supply power to the driver stage and the logic part.

The power supply input connector offers a driver enable input. This input has to be connected to any voltage above 3.5V up-to max. supply voltage of 54V in order to enable the driver stage. Leaving this pin unconnected or connected to ground (voltage below 2.4V) will disable the driver stage regardless of any settings in software. This input may be connected to main power supply input permanently in case an enable input in hardware is not required.

Power Supply Connector Pin Assignment			
Pin	Label	Direction	Description
1	GND	Power (GND)	Common system supply and signal ground
2	V _{MAIN}	Power (input)	Main power supply input for the driver and on-board logic 12...54V
3	Enable	Digital input	Driver enable input. A voltage above 3.5V is required here in order to enable the on-board stepper motor driver. This input maybe connected to main power supply input in order to enable the driver stage.
4	V _{LOGIC}	Power (input)	Optional separate power supply input for the on-board logic 12...54V

Table 5: Power Supply Connector Pin Assignment

NOTICE

Do not connect or disconnect motor during operation! Motor cable and motor inductivity might lead to voltage spikes when the motor is (dis)connected while energized. These voltage spikes might exceed voltage limits of the driver MOSFETs and might permanently damage them. Therefore, always switch off / disconnect power supply or at least disable driver stage before connecting / disconnecting motor.

NOTICE

Take care of polarity, wrong polarity can destroy the board!

NOTICE

Connect Enable pin to voltage >3.5V in order to enable motor movements!



4.2 Motor Connector

Two four pin motor connectors are available. Either of them can be used for connecting a bipolar stepper motor. Both connectors are connected to the same driver stage therefore, just one connector should be used at the same time. While the more compact 4pin JST EH series connector is suitable for motor currents up-to 3A RMS the larger JST VH series connector is able to support all motor current up-to 6A RMS (limit of the unit). With the PANdrive version motor current is limited to 3A RMS and the JST EH connector is used, only.

Motor Connector Pin Assignment			
Pin	Label	Direction	Description
1	B1	out	Pin 1 of motor coil B
2	B2	out	Pin 2 of motor coil B
3	A1	out	Pin 1 of motor coil A
4	A2	out	Pin 2 of motor coil A

Table 6: Motor Connector Pin Assignment

NOTICE

Connect just one motor connector at the same time! Both connectors are connected to the same driver stage.

NOTICE

Do not connect or disconnect motor during operation! Motor cable and motor inductivity might lead to voltage spikes when the motor is (dis)connected while energized. These voltage spikes might exceed voltage limits of the driver MOSFETs and might permanently damage them. Therefore, always switch off / disconnect power supply or at least disable driver stage before connecting / disconnecting motor.

NOTICE

Do not mix-up power supply connector and the larger motor connector!

4.3 RS485 + CAN Connector

For serial communication the PD57/60/86-x-1260 offers selection between RS485, CAN and USB interfaces. While the USB interface is available for configuration and service of the board, mainly (e.g. parameter settings, firmware updates) a 5-pin JST PH series connector offers 2-wire RS485 and CAN interfaces for in system communication.

NOTICE

Due to hardware resource sharing USB and CAN communication interfaces are not available at the same time. As soon as USB is physically attached to a host or hub the CAN interface will be switched off.

RS485 + CAN Connector Pin Assignment			
Pin	Label	Direction	Description
1	GND	Power (GND)	Common system supply and signal ground
2	RS485+	Bidirectional	RS485 interface, diff. signal (non-inverting)



Pin	Label	Direction	Description
3	RS485-	Bidirectional	RS485 interface, diff. signal (inverting)
4	CAN_H	Bidirectional	CAN interface, diff. signal (non-inverting)
5	CAN_L	Bidirectional	CAN interface, diff. signal (inverting)

Table 7: RS485 + CAN Connector Pin Assignment

4.4 USB Connector

For serial communication the PD57/60/86-x-1260 offers selection between RS485, CAN and USB interfaces. The USB interface via on-board micro-USB connector (type B) is available for configuration and service of the board, mainly (e.g. parameter settings, firmware updates). The USB device interface supports full speed (12Mbit/s) communication and supports bus powered and self-powered operation. During bus-powered operation the low voltage logic part of the board will be powered, only. This includes the microcontroller and the non-volatile memory and therefore allows parameter settings and firmware updates of the board using a standard USB cable, only. Of course, for any motor movement main supply via supply input connector is required.

NOTICE

Due to hardware resource sharing USB and CAN communication interfaces are not available at the same time. As soon as USB is physically attached to a host or hub the CAN interface will be switched off.

USB Connector Pin Assignment			
Pin	Label	Direction	Description
1	VBUS	Power (+5V)	USB +5V nom. power supply input
2	D-	Bidirectional	USB interface, diff. signal (inverting)
3	D+	Bidirectional	USB interface, diff. signal (inverting)
4	ID	Input	connected to GND (via 100k resistor)
5	GND	Power (GND)	Common system supply and signal ground

Table 8: USB Connector Pin Assignment

4.5 I/O Connector

The PD57/60/86-x-1260 offers several inputs (two of them optically isolated) and one digital (open-drain) output. The inputs include support for stop switches (left and right), home switch, step/direction, incremental A/B channel encoder and analog (0...+10V) input. All this functionality is available via one 8pin JST PH series I/O connector.

USB Connector Pin Assignment			
Pin	Label	Direction	Description
1	GND	Power (GND)	Common system supply and signal ground
2	IN0/HOME	Input	Analog input (0...+10V) HOME switch input +24V tolerant, programmable (separate) pull-up to +5V



Pin	Label	Direction	Description
3	IN1/ENC_A	Input	General purpose digital input Incremental encoder input channel A <i>+24V tolerant, programmable pull-up (for IN1/IN2 together) to +5V</i>
4	IN2/ENC_B	Input	General purpose digital input Incremental encoder input channel B <i>+24V tolerant, programmable pull-up (for IN1/IN2 together) to +5V</i>
5	STOP_L/STEP	Input	STOP left switch input STEP pulse input <i>input optically isolated, +24V compatible</i>
6	STOP_R/DIR	Input	STOP right switch input DIR input <i>input optically isolated, +24V compatible</i>
7	ISO_COM	Power	Common positive (+24V_ISO) or negative (GND_ISO) isolated supply input for optically isolated inputs
8	OUT0	Output (OD)	Open-Drain output. Output will be pulled low when activated. <i>Voltages up-to logic supply input level (or main supply input in case separate logic supply is not used) are supported here. Max. continuous pull-down current: 100mA</i>

Table 9: I/O Connector Pin Assignment

All pins marked light green offer functional isolation towards main supply input. In case this is not required ISO_COM may be connected to main ground or supply input, of course. The opto-coupler used are AC types. This way, either high side switches or low side switches for both inputs are supported.

5 On-Board LEDs

The board offers two LEDs in order to indicate board status. The function of both LEDs is dependent on the firmware version. With standard TMCL firmware the green LED should be flashing slowly during operation and the red LED should be off. When there is no valid firmware programmed into the board or during firmware update the red and green LEDs are permanently switched on. During reset to factory default values the green LED will be flashing fast. With CANopen firmware both LEDs are switched on/off/flashing according to standard definition.



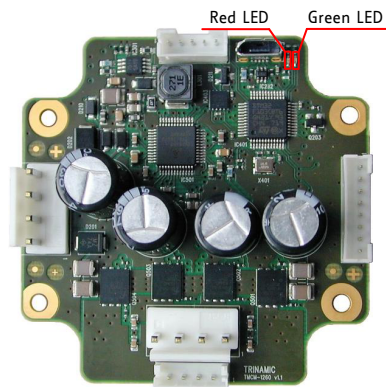

Figure 2: PD57/60/86-x-1260 LEDs

6 Reset to Factory Defaults

It is possible to reset all settings in firmware for the PD57/60/86-x-1260 to factory defaults without establishing a working communication connection. This might be helpful in case communication parameters of the preferred interface have been set to unknown values or got lost.

For this procedure two pads on the bottom side of the module have to be shorted (electrically connected with each other) during power-on.

Please perform the following steps:

1. Switch power supply OFF (and disconnect USB cable if applicable)
2. Short CLK and DIO pads of programming pads on bottom of pcb (see figure 3)
3. Switch power supply ON again (or connect USB again if applicable)
4. Wait until the on-board red and green LEDs start flashing fast (this might take a while)
5. Switch power supply OFF again (and disconnect USB cable if applicable)
6. Remove short between pads
7. After switching power supply ON again (and / or connecting USB cable) all permanent settings have been restored to factory defaults

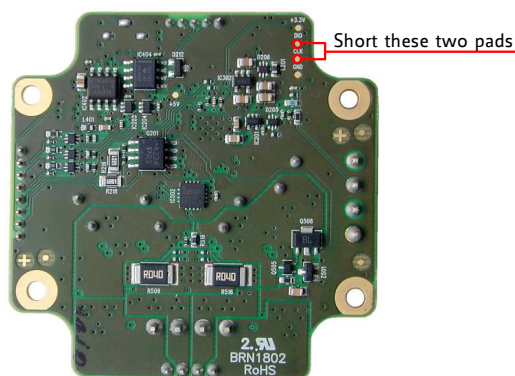

Figure 3: Reset to factory default settings



7 I/Os

The I/O connector (8pin JST PH series) offers one analog input, two non-isolated digital inputs with integrated pull-ups (programmable) and two optically isolated inputs. All inputs can be used for different purposes explained in more detail in the following subsections.

7.1 Analog input IN0

The PD57/60/86-x-1260 offers one analog input. The analog input voltage range is approx. 0..+10V. For voltages above +10V saturation takes place but, up-to 30V higher voltages are tolerated without destroying the input. For analog to digital conversion the integrated ADC of the on-board microcontroller is used. Resolution of this converter is 12bit (0..4095).

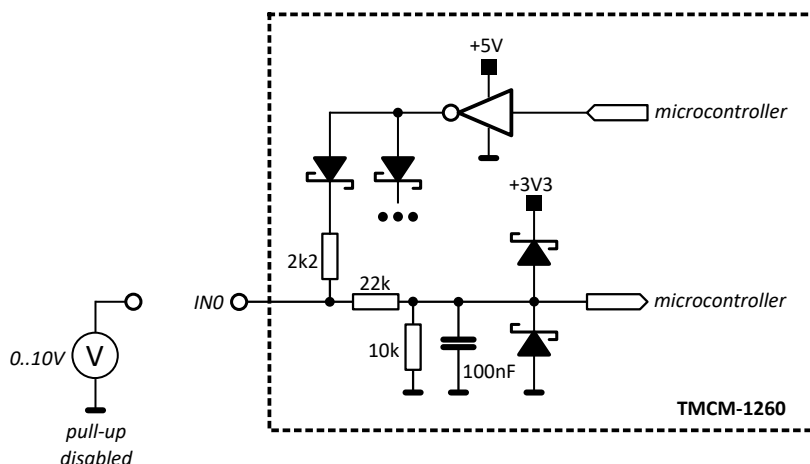

Figure 4: Analog input IN0

The analog input can be used as digital input, also. There is an integrated pull-up to +5V which can be switched on of off in software. When using this input as analog input the pull-up should be usually switched off.

7.2 Digital inputs IN1 and IN2

The PD57/60/86-x-1260 offers two digital inputs IN1 and IN2 which accept signals between 0 and 30V with voltages above approx. 2.9V recognized as logical '1' and below 1V as logical '0'. Both inputs offer intergated pull-ups to +5V which can be switched on or off in software (always together). When using the inputs with low-side switches (connected to GND), pull-ups usually should be switched on (default). In case high-side switches are used the pull-ups must be switched off. For push-pull signals the pull-ups may be either switched on or off.



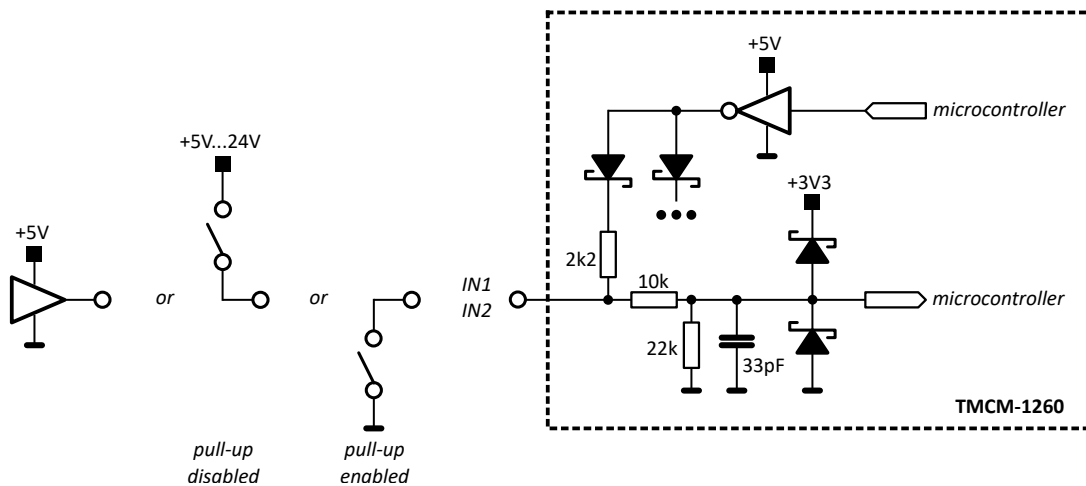

Figure 5: Digital inputs IN1 and IN2

7.3 HOME/STOP_L/STOP_R switch inputs

The PD57/60/86-x-1260 offers two optically isolated inputs which can be used as left (STOP_L) and right (STOP_R) stop switch inputs. When enabled in software the STOP_L switch input will stop motor movement in negative direction (step counter decreasing) while activated. Likewise the STOP_R switch input will stop motor movement in positive direction (step counter increasing) while activated.

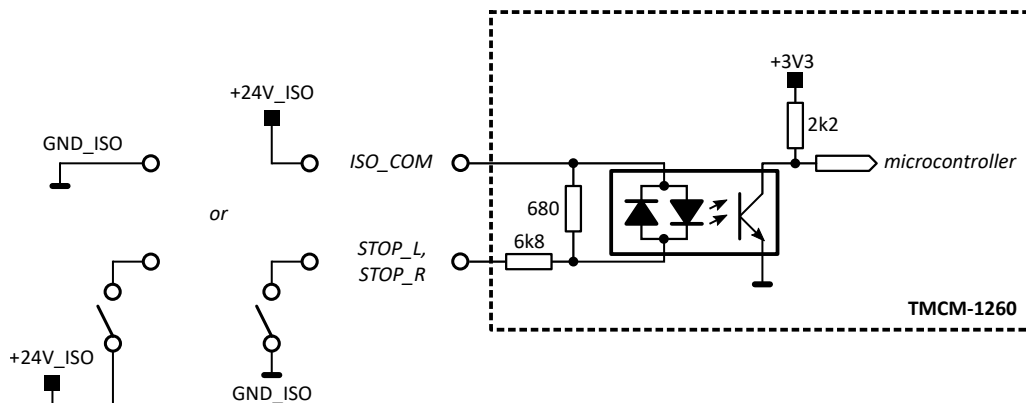

Figure 6: Stop switch inputs

A separated / isolated supply may be used for the switches - as indicated in the drawing (+24V_ISO and related GND_ISO) - but, same supply as for the PD57/60/86-x-1260 can be used, also, of course.

7.4 External incremental encoder input

The PD57/60/86-x-1260 offers an integrated hall-sensor based magnet encoder. In addition, an external incremental A/B encoder may be connected to the two digital inputs IN1 and IN2. Encoder with push-pull signals (e.g. +5V TTL) and open-drain output signals are supported (single-ended). For open-drain outputs the internal pull-ups should be activated in software (default mode).



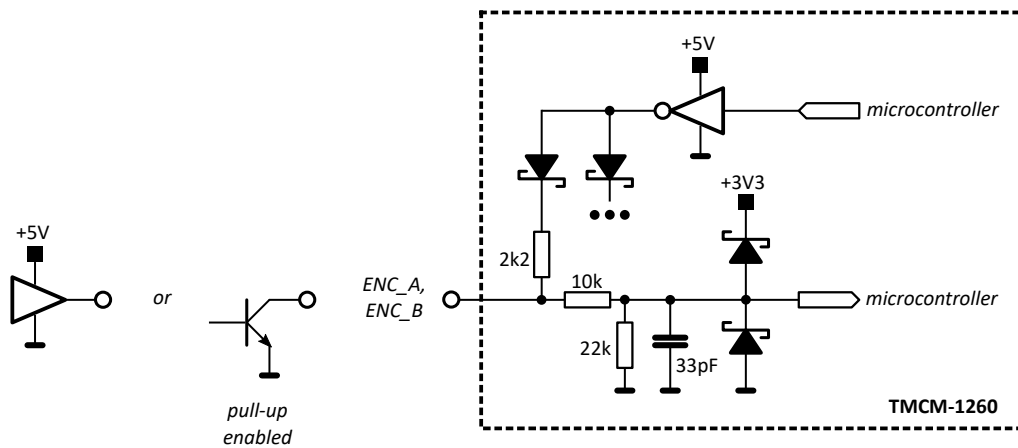

Figure 7: External encoder input

7.5 Step/Direction inputs

The PD57/60/86-x-1260 may be used as driver with an external motion controller. In this case the Step/Direction output signals of the external motion controller may be connected to the optically isolated Step/Dir inputs of the PD57/60/86-x-1260. Please note that these signals should be 24V signals. For lower voltage signals a simple small signal transistor may be inserted as level converter.

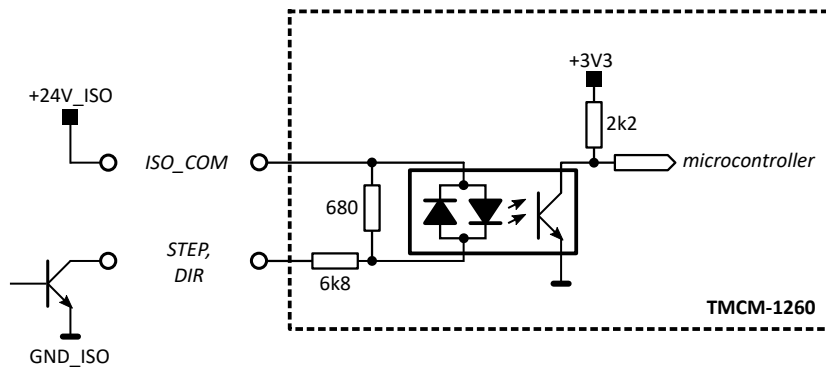

Figure 8: Step/Direction input

Due to limitations of the opto-isolators the maximum step frequency of these inputs is limited to around 20kHz. For higher motor speed the step interpolator of the driver stage should be activated or the microstep resolution reduced (default 256 microsteps per fullstep).



8 Communication

8.1 RS485

For remote control and communication with a host system the PD57/60/86-x-1260 provides a two wire RS485 bus interface. For proper operation the following items should be taken into account when setting up an RS485 network:

1. **BUS STRUCTURE:**

The network topology should follow a bus structure as closely as possible. That is, the connection between each node and the bus itself should be as short as possible. Basically, it should be short compared to the length of the bus.

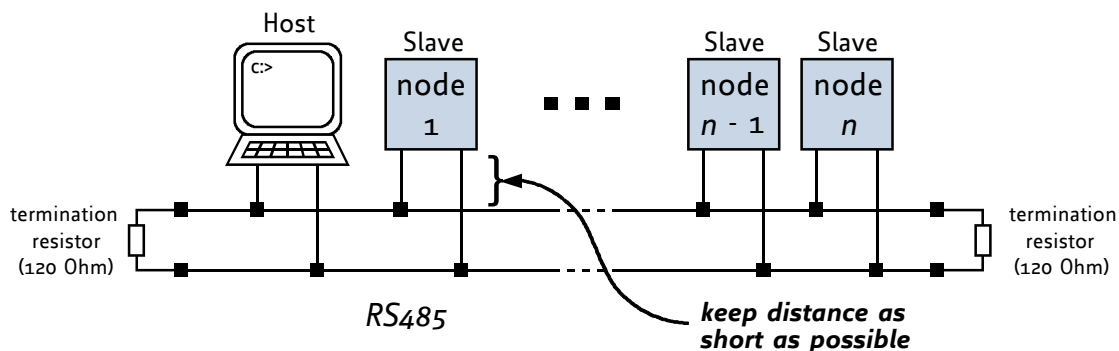

Figure 9: RS485 bus structure with termination resistors

2. **BUS TERMINATION:**

Especially for longer busses and/or multiple nodes connected to the bus and/or high communication speeds, the bus should be properly terminated at both ends. The PD57/60/86-x-1260 does not integrate any termination resistor. Therefore, 120 Ohm termination resistors at both ends of the bus have to be added externally.

3. **NUMBER OF NODES:**

The RS485 electrical interface standard (EIA-485) allows up to 32 nodes to be connected to a single bus. The bus transceiver used on the PD57/60/86-x-1260 units (SN65HVD1781D) offers a significantly reduced bus load compared to the standard and allows a maximum of 255 units to be connected to a single RS485 bus using standard TMCL firmware. *Please note: usually it cannot be expected to get reliable communication with the maximum number of nodes connected to one bus and maximum supported communication speed at the same time. Instead, a compromise has to be found between bus cable length, communication speed and number of nodes.*

4. **COMMUNICATION SPEED:**

The maximum RS485 communication speed supported by the PD57/60/86-x-1260 hardware is 1Mbit/s. Factory default is 9600 bit/s. Please see separate PD57/60/86-x-1260 TMCL firmware manual for information regarding other possible communication speeds below the upper hardware limit.

5. **NO FLOATING BUS LINES:**

Avoid floating bus lines while neither the host/master nor one of the slaves along the bus line is transmitting data (all bus nodes switched to receive mode). Floating bus lines may lead to communication errors. In order to ensure valid signals on the bus it is recommended to use a resistor network connecting both bus lines to well defined logic levels.

There are actually two options which can be recommended: Add resistor (bias) network on one side of the bus, only (120R termination resistor still at both ends):



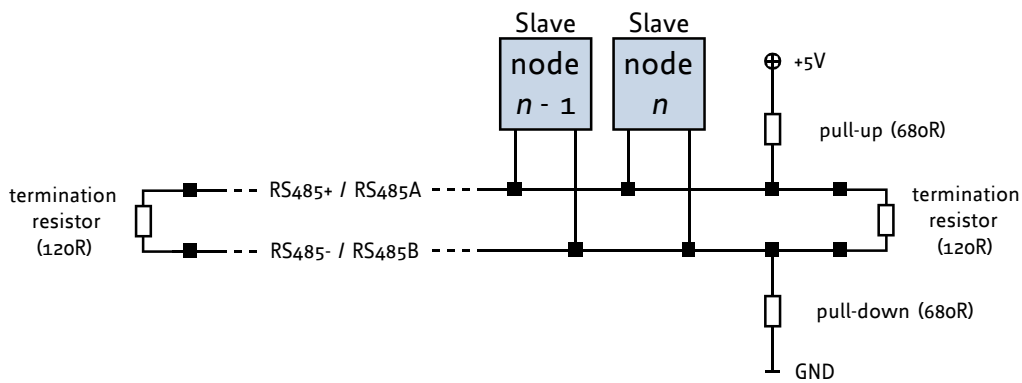

Figure 10: RS485 bus lines with resistor (bias) network on one side, only

Or add resistor network at both ends of the bus (like Profibus™ termination):

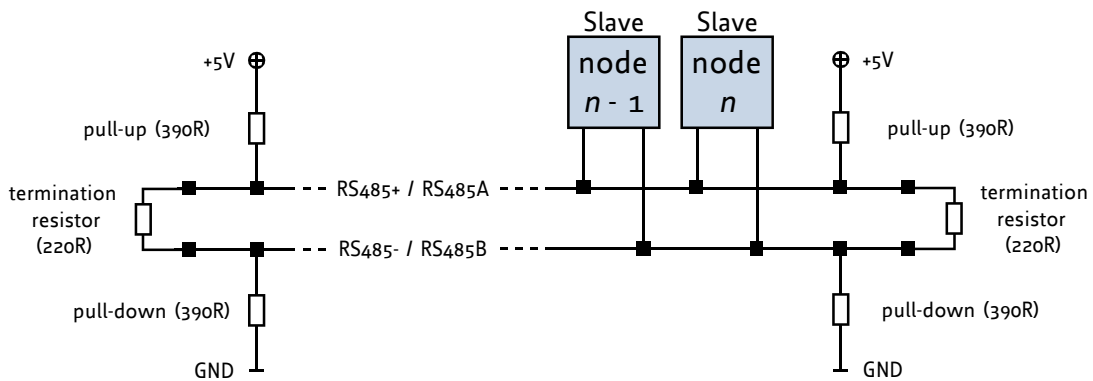

Figure 11: RS485 bus lines with Profibus™ recommended line termination

8.2 CAN

For remote control and communication with a host system the PD57/60/86-x-1260 provides a CAN bus interface. Please note that the CAN interface is not available in case USB is connected. For proper operation the following items should be taken into account when setting up a CAN network:

1. BUS STRUCTURE:

The network topology should follow a bus structure as closely as possible. That is, the connection between each node and the bus itself should be as short as possible. Basically, it should be short compared to the length of the bus.



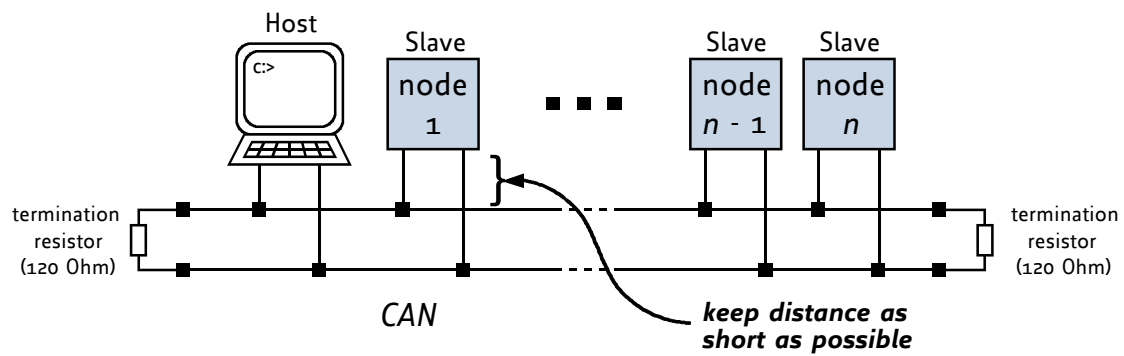

Figure 12: CAN bus structure with termination resistors

2. **BUS TERMINATION:**

Especially for longer busses and/or multiple nodes connected to the bus and/or high communication speeds, the bus should be properly terminated at both ends. The PD57/60/86-x-1260 does not integrate any termination resistor. Therefore, 120 Ohm termination resistors at both ends of the bus have to be added externally.

3. **BUS TERMINATION:**

The bus transceiver used on the PD57/60/86-x-1260 units (TJA1051T) supports at least 110 nodes under optimum conditions. Practically achievable number of nodes per CAN bus highly depend on bus length (longer bus -> less nodes) and communication speed (higher speed -> less nodes).



9 Motor driver current

The on-board stepper motor driver operates current controlled. The driver current may be programmed in software with 32 effective scaling steps in hardware.

Explanation of different columns in table below:

Motor current setting in software (TMCL) These are the values for TMCL axis parameter 6 (motor run current) and 7 (motor standby current). They are used to set the run / standby current using the following TMCL commands:

SAP 6, 0, <value> // set run current

SAP 7, 0, <value> // set standby current

(read-out value with GAP instead of SAP. Please see separate PD57/60/86-x-1260 firmware manual for further information)

Motor current I_{RMS} [A] Resulting motor current based on motor current setting

NOTICE

For the PD57-1-1260, PD57-2-1260, PD60-3-1260 and PD60-4-1260 line of PAN-Drives™ the maximum motor current setting for the TMCM-1260 electronics has been limited to 3A RMS in order to avoid any damage to the attached motors. The TMCM-1260 separately available without motor supports motor current settings up-to 6A RMS.

Motor current setting in software (TMCL)	Current scaling step (CS)	Motor current I_{COIL} [A] peak	Motor current I_{COIL} [A] RMS
0...7	0	0.127	0.090
8...15	1	0.254	0.180
16...23	2	0.381	0.269
24...31	3	0.508	0.359
32...39	4	0.635	0.449
40...47	5	0.762	0.539
48...55	6	0.889	0.628
56...63	7	1.016	0.718
64...71	8	1.143	0.808
72...79	9	1.270	0.898
80...87	10	1.396	0.987
88...95	11	1.523	1.077
96...103	12	1.650	1.167
104...111	13	1.777	1.257
112...119	14	1.904	1.347
120...127	15	2.031	1.436



Motor current setting in software (TMCL)	Current scaling step (CS)	Motor current I_{COIL} [A] peak	Motor current I_{COIL} [A] RMS
128...135	16	2.158	1.526
136...143	17	2.285	1.616
144...151	18	2.412	1.706
152...159	19	2.539	1.795
160...167	20	2.666	1.885
168...175	21	2.793	1.975
176...183	22	2.920	2.065
184...191	23	3.047	2.154
192...199	24	3.174	2.244
200...207	25	3.301	2.334
208...215	26	3.428	2.424
216...223	27	3.555	2.514
224...231	28	3.682	2.603
232...239	29	3.809	2.693
240...247	30	3.936	2.783
248...255	31	4.063	2.873

Table 11: Available motor current settings

In addition to the settings in the table the motor current may be switched off completely (free-wheeling) using axis parameter 204 (see PD57/60/86-x-1260 firmware manual).



10 Torque curves

10.1 PD57-1-1260 Torque Curve

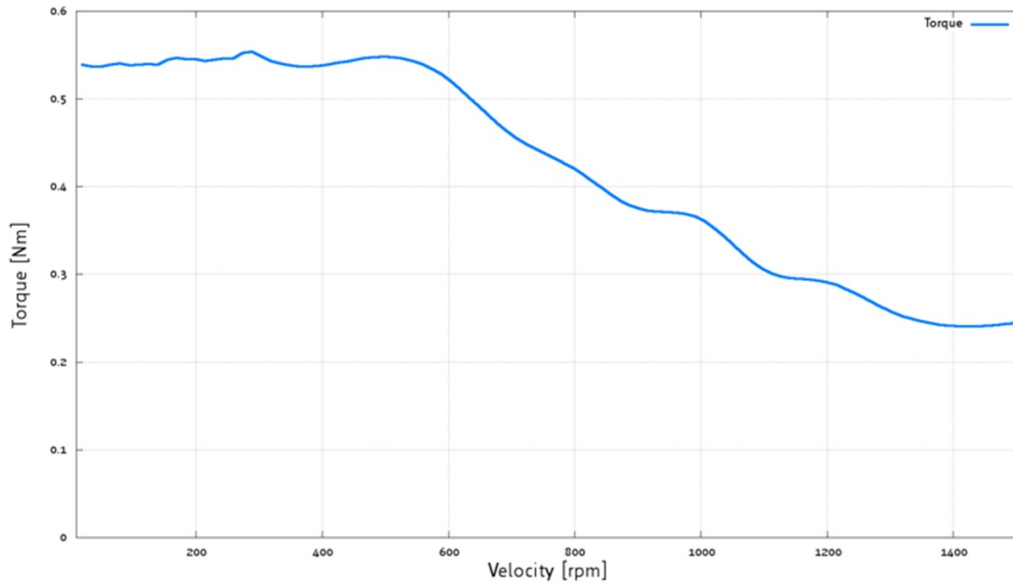

Figure 13: PD57-1-1260 torque vs. velocity 24V / 2.8A, 256µsteps

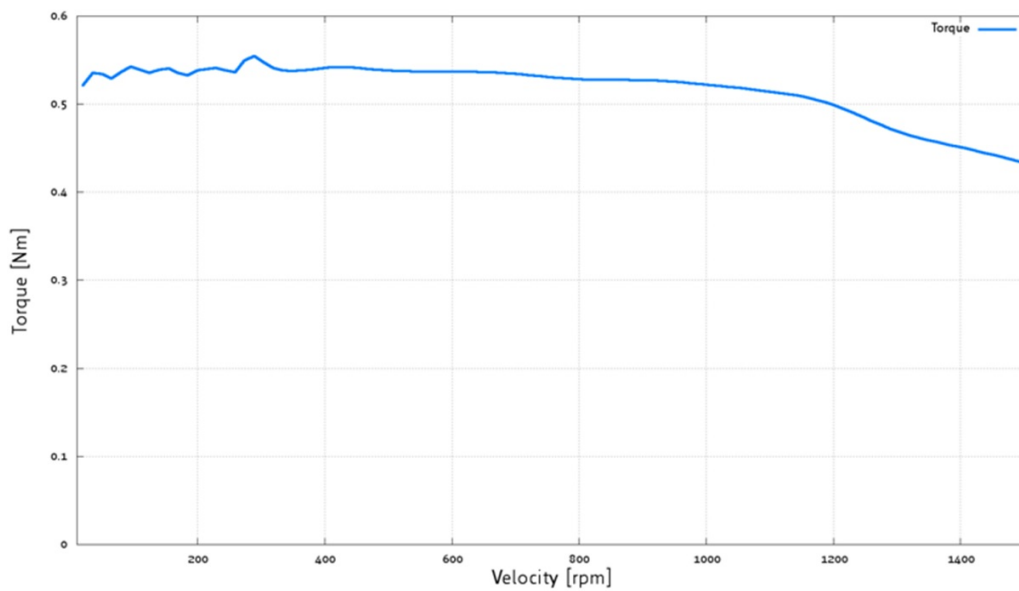

Figure 14: PD57-1-1260 torque vs. velocity 48V / 2.8A, 256µsteps



10.2 PD57-2-1260 Torque Curve

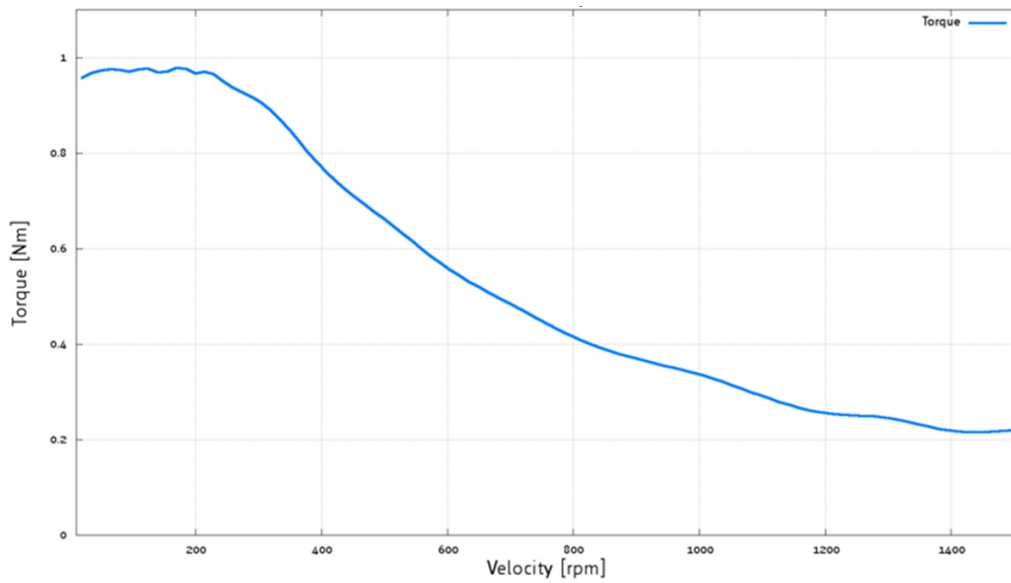

Figure 15: PD57-2-1260 torque vs. velocity 24V / 2.8A, 256µsteps

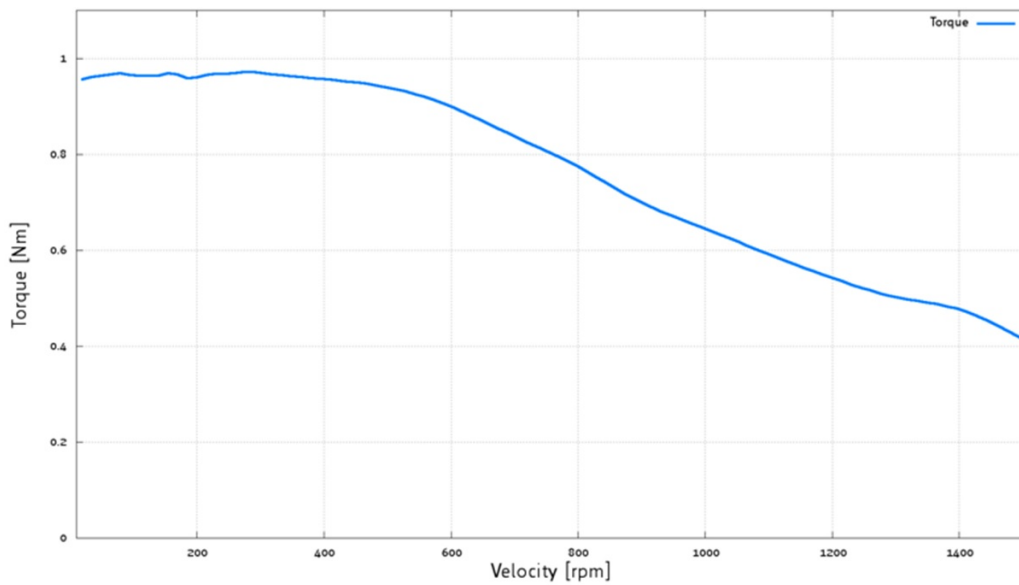

Figure 16: PD57-2-1260 torque vs. velocity 48V / 2.8A, 256µsteps



10.3 PD60-3-1260 Torque Curve

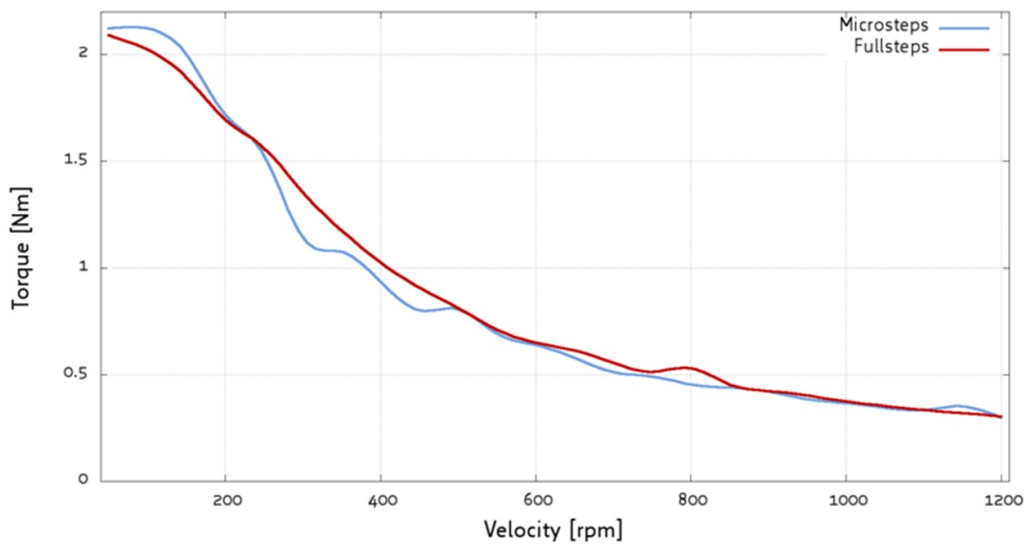

Figure 17: PD60-3-1260 torque vs. velocity 24V / 2.8A, 256µsteps

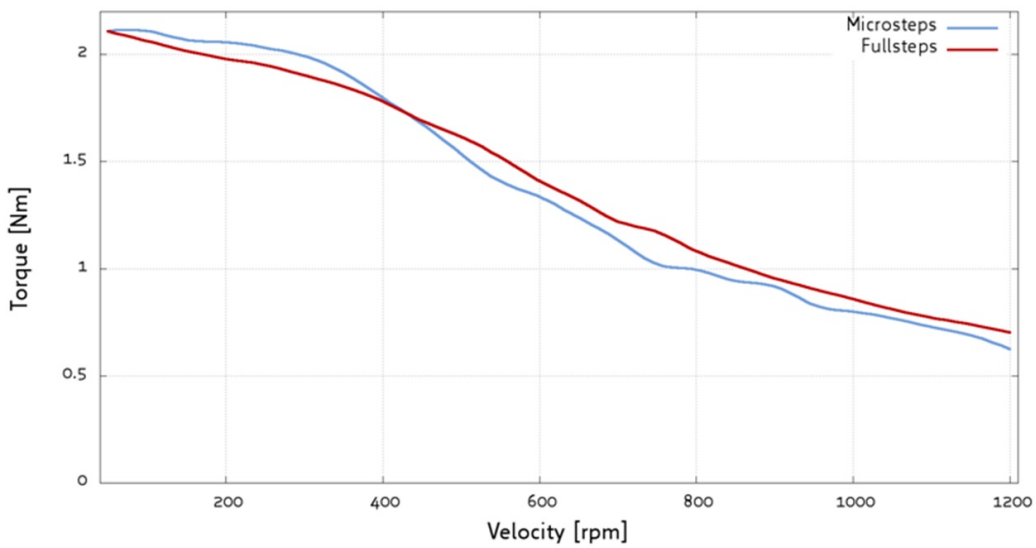

Figure 18: PD60-3-1260 torque vs. velocity 48V / 2.8A, 256µsteps



10.4 PD60-4-1260 Torque Curve

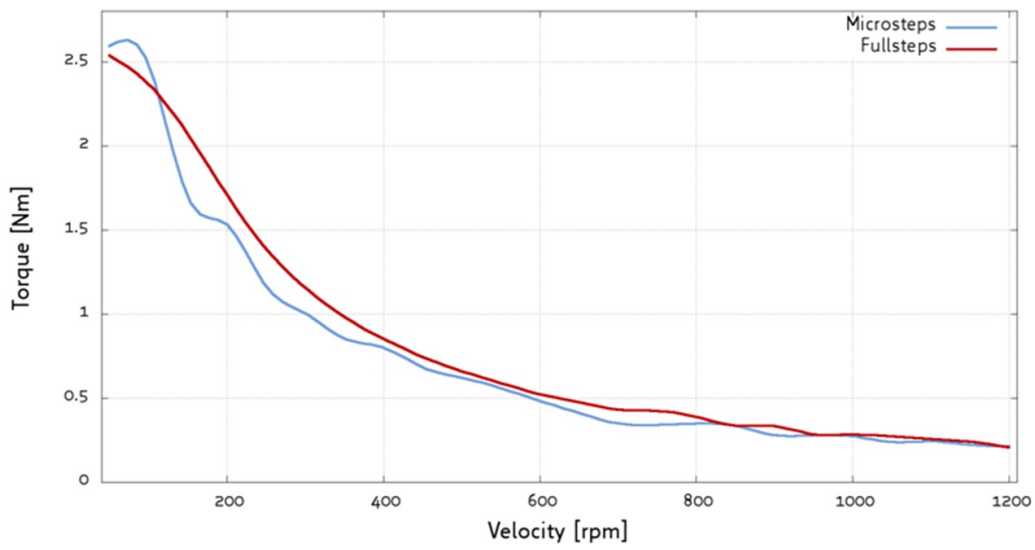

Figure 19: PD60-4-1260 torque vs. velocity 24V / 2.8A, 256µsteps

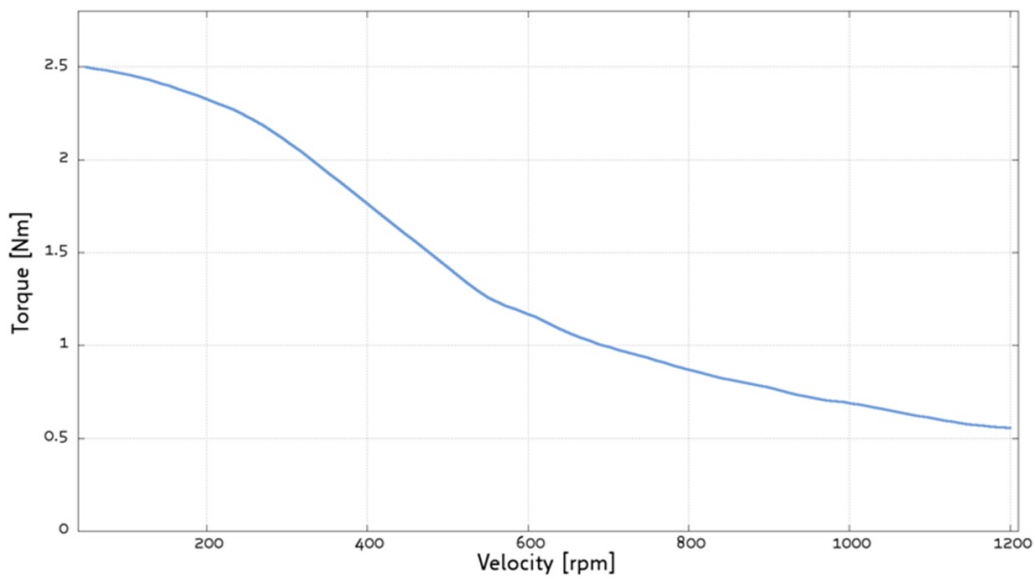

Figure 20: PD60-4-1260 torque vs. velocity 48V / 2.8A, 256µsteps



10.5 PD86-3-1260 Torque Curve

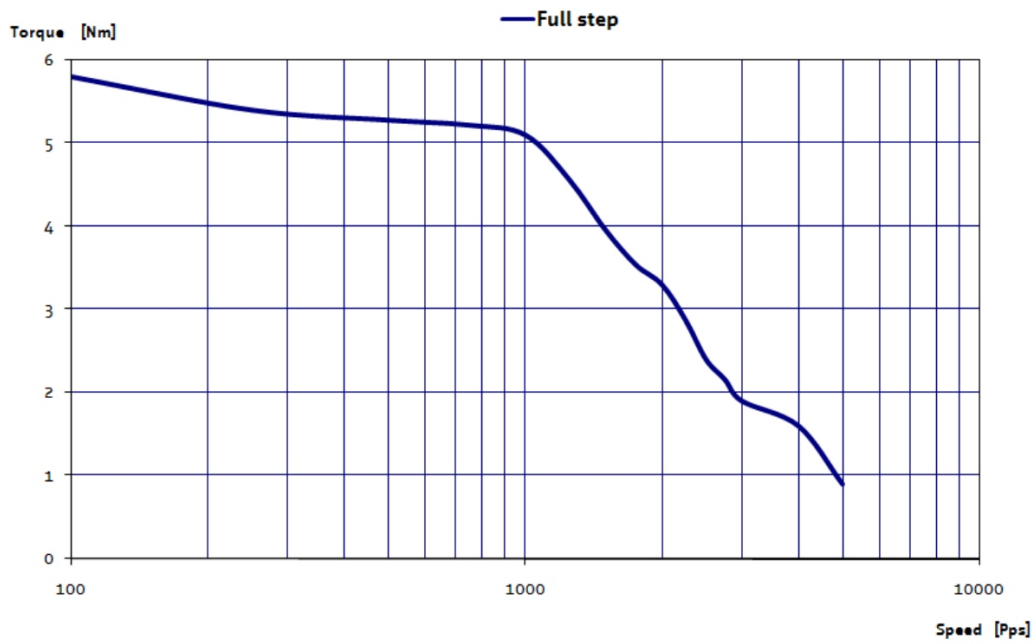

Figure 21: PD86-3-1260 torque vs. velocity 48V / 5.5A, full step operation



11 Functional Description

The PD57/60/86-x-1260 is a full mechatronic solution including a NEMA23 or NEMA24 or NEMA34 flange size bipolar stepper motor. It includes the controller / driver electronics TMCM-1260 and a choice between five different NEMA 23 / 57mm and NEMA24 / 60mm and NEMA34 / 86mm flange size bipolar hybrid stepper motors with different length and torque. The PD57/60/86-x-1260 can be controlled via USB, RS485 or CAN serial interfaces. There are three general purpose digital inputs which can be used, also as STOP_L / STOP_R / HOME switch inputs (for reference movements, as end switches etc. depending on firmware, mode and configuration) or for connecting an additional external encoder (incremental A/B/N). In addition, there is one dedicated analog input for 0...+10V analog signals and two general-purpose outputs (one open-drain and one switchable +5V supply output).

The PD57/60/86-x-1260 with TMCL™ firmware option is supported by the PC based software development environment TMCL-IDE for the Trinamic Motion Control Language (TMCL™). Using predefined TMCL™ high level commands like move to position a rapid and fast development of motion control applications is guaranteed. Please refer to the PD57/60/86-x-1260 or TMCM-1260 firmware manuals for more information about TMCL™ commands.

Communication traffic is kept low since all time critical operations, e.g. ramp calculation are performed on board. Complete stand-alone or full remote control or anything in-between is possible. The firmware of the module can be updated via the serial interface. As an alternative to TMCL, a CANopen firmware is available.

The PD57/60/86-x-1260 module contains the following main components:

- Microcontroller (ARM Cortex-M3™), responsible for overall control and communication
- Highly integrated advanced stepper motor controller supporting linear and unique 6-points ramps in hardware
- Advanced stepper motor driver with stallGuard2™ and coolStep™ with MOSFET driver stage (8x power N-MOSFETs for bipolar stepper motor)
- RS485, CAN and USB transceivers
- On-board voltage regulators (+5V and +3V3) required for supply of all on-board digital circuits

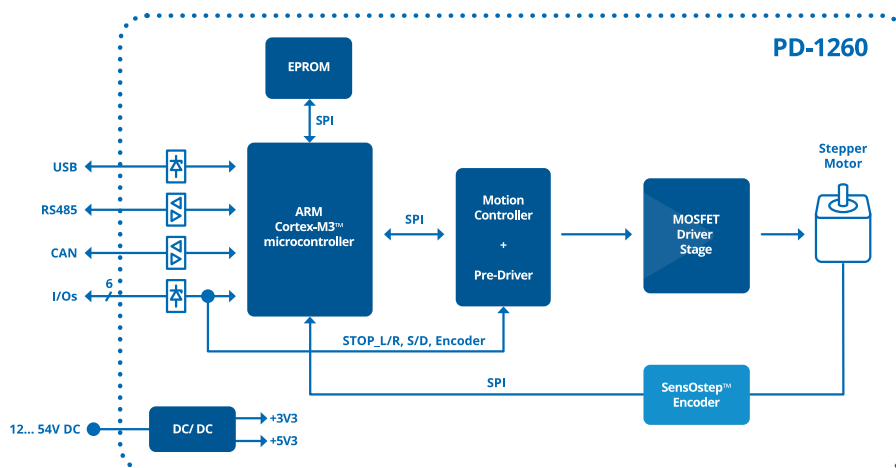

Figure 22: PD57/60/86-x-1260 block diagram



12 Operational Ratings and Characteristics

NOTICE

Never Exceed the absolute maximum ratings! Keep the power supply voltage below the upper limit of +54V! Otherwise the board electronics will seriously be damaged! Especially, when the selected operating voltage is near the upper limit a regulated power supply is highly recommended.

General Operational Ratings					
Symbol	Parameter	Min	Typ	Max	Unit
V_{Power}	Power supply voltage	12	24...48	54	V
I_{Power}	Power supply current		$\ll I_{COIL_RMS}$	$1.4 \times I_{COIL_RMS}$	A
V_{USB}	Power supply via USB connector		5		V
I_{USB}	Current withdrawn from USB supply when USB bus powered (no other supply connected)		43		mA
$I_{COIL_PEAK5760}$	Motor coil current for sine wave peak for PD57-x-1260 and PD60-x-1260 (chopper regulated, adjustable via software)	0		4	A
I_{COIL_PEAK86}	Motor coil current for sine wave peak for PD86-3-1260 (chopper regulated, adjustable via software)	0		8.2	A
I_{COIL_RMS}	Continuous motor current (RMS)	0		6	A
T_{ENV}	Environmental temperature at maximum rated current (no forced cooling required)	-30		40	°C

Table 12: General operational ratings of the module

Operational Ratings of the I/Os					
Symbol	Parameter	Min	Typ	Max	Unit
V_{OUT0}	Voltage at open drain output OUT0 (switched off)	0		$+V_{Power}$	V
I_{OUT0}	Output sink current of open drain output OUT0 (switched on)			100	mA
$V_{IN0/1/2}$	Input voltage for IN0...IN2	0	0...+24	+30	V
V_{IN0}	Measurement range for analog input IN0	0		+10 ¹	V
$V_{IN1/2_L}$	Low level voltage for IN1 and IN2 (digital inputs)			1	V
$V_{IN1/2_H}$	High level voltage for IN1 and IN2 (digital inputs)	2.9			V
V_{STOP_L/R_ON}	Switch-On opto-isolated inputs (voltage between input and ISO_COM)		20-24	30	V

¹ approx. 0...+10.56V at the analog input IN0 is translated to 0...4095 (12bit ADC, raw values). Above approx. +10.56V the analog input will saturate but, not being damaged (up-to VDD).



Operational Ratings of the I/Os					
Symbol	Parameter	Min	Typ	Max	Unit
V_{STOP_L/R_OFF}	Switch-off opto-isolated inputs (voltage between input and ISO_COM)	0	0-16		V
$f_{STEP/DIR}$	Max. frequency for step/direction opto-isolated inputs		20		kHz

Table 13: Operational ratings of I/Os

Operational Ratings of the RS485 Interface					
Symbol	Parameter	Min	Typ	Max	Unit
N_{RS485}	Number of nodes connected to single RS485 network			256	
f_{RS485}	Max. speed for RS485 network			1Mbit/s	

Table 14: Operational ratings of the RS485 interface

Operational Ratings of the CAN Interface					
Symbol	Parameter	Min	Typ	Max	Unit
N_{CAN}	Number of nodes connected to single CAN network			>110	
f_{CAN}	Max. speed for CAN network			1Mbit/s	

Table 15: Operational ratings of the CAN interface



13 Abbreviations used in this Manual

Abbreviation	Description
IDE	Integrated Development Environment
LED	Light Emmitting Diode
RMS	Root Mean Square value
TMCL	TRINAMIC Motion Control Language

Table 16: Abbreviations used in this Manual



14 Figures Index

1	PD57/60/86-x-1260 connectors	14	14	PD57-1-1260 torque vs. velocity 48V / 2.8A, 256 μ steps	28
2	PD57/60/86-x-1260 LEDs	19	15	PD57-2-1260 torque vs. velocity 24V / 2.8A, 256 μ steps	29
3	Reset to factory default settings	19	16	PD57-2-1260 torque vs. velocity 48V / 2.8A, 256 μ steps	29
4	Analog input IN0	20	17	PD60-3-1260 torque vs. velocity 24V / 2.8A, 256 μ steps	30
5	Digital inputs IN1 and IN2	21	18	PD60-3-1260 torque vs. velocity 48V / 2.8A, 256 μ steps	30
6	Stop switch inputs	21	19	PD60-4-1260 torque vs. velocity 24V / 2.8A, 256 μ steps	31
7	External encoder input	22	20	PD60-4-1260 torque vs. velocity 48V / 2.8A, 256 μ steps	31
8	Step/Direction input	22	21	PD86-3-1260 torque vs. velocity 48V / 5.5A, full step operation	32
9	RS485 bus structure with termination resistors	23	22	PD57/60/86-x-1260 block diagram	33
10	RS485 bus lines with resistor (bias) network on one side, only	24			
11	RS485 bus lines with Profibus™recommended line termination	24			
12	CAN bus structure with termination resistors	25			
13	PD57-1-1260 torque vs. velocity 24V / 2.8A, 256 μ steps	28			



15 Tables Index

1	TMCM-1260 Order Code	7	9	I/O Connector Pin Assignment	18
2	TMCM-1260 Cable Loom	7	11	Available motor current settings	27
3	NEMA23, NEMA24, and NEMA34 stepper motor technical data	12	12	General operational ratings of the module	34
4	Connector Types and Mating Connectors of the PD57/60/86-x-1260	15	13	Operational ratings of I/Os	35
5	Power Supply Connector Pin Assignment	15	14	Operational ratings of the RS485 interface	35
6	Motor Connector Pin Assignment	16	15	Operational ratings of the CAN interface	35
7	RS485 + CAN Connector Pin Assignment	17	16	Abbreviations used in this Manual	36
8	USB Connector Pin Assignment	17	17	Hardware Revision	41
			18	Document Revision	41



16 Supplemental Directives

16.1 Producer Information

16.2 Copyright

TRINAMIC owns the content of this user manual in its entirety, including but not limited to pictures, logos, trademarks, and resources. © Copyright 2021 TRINAMIC. All rights reserved. Electronically published by TRINAMIC, Germany.

Redistribution of sources or derived formats (for example, Portable Document Format or Hypertext Markup Language) must retain the above copyright notice, and the complete data sheet, user manual, and documentation of this product including associated application notes; and a reference to other available product-related documentation.

16.3 Trademark Designations and Symbols

Trademark designations and symbols used in this documentation indicate that a product or feature is owned and registered as trademark and/or patent either by TRINAMIC or by other manufacturers, whose products are used or referred to in combination with TRINAMIC's products and TRINAMIC's product documentation.

This Hardware Manual is a non-commercial publication that seeks to provide concise scientific and technical user information to the target user. Thus, trademark designations and symbols are only entered in the Short Spec of this document that introduces the product at a quick glance. The trademark designation /symbol is also entered when the product or feature name occurs for the first time in the document. All trademarks and brand names used are property of their respective owners.

16.4 Target User

The documentation provided here, is for programmers and engineers only, who are equipped with the necessary skills and have been trained to work with this type of product.

The Target User knows how to responsibly make use of this product without causing harm to himself or others, and without causing damage to systems or devices, in which the user incorporates the product.

16.5 Disclaimer: Life Support Systems

TRINAMIC Motion Control GmbH & Co. KG does not authorize or warrant any of its products for use in life support systems, without the specific written consent of TRINAMIC Motion Control GmbH & Co. KG.

Life support systems are equipment intended to support or sustain life, and whose failure to perform, when properly used in accordance with instructions provided, can be reasonably expected to result in personal injury or death.

Information given in this document is believed to be accurate and reliable. However, no responsibility is assumed for the consequences of its use nor for any infringement of patents or other rights of third parties which may result from its use. Specifications are subject to change without notice.

16.6 Disclaimer: Intended Use

The data specified in this user manual is intended solely for the purpose of product description. No representations or warranties, either express or implied, of merchantability, fitness for a particular purpose



or of any other nature are made hereunder with respect to information/specification or the products to which information refers and no guarantee with respect to compliance to the intended use is given.

In particular, this also applies to the stated possible applications or areas of applications of the product. TRINAMIC products are not designed for and must not be used in connection with any applications where the failure of such products would reasonably be expected to result in significant personal injury or death (safety-Critical Applications) without TRINAMIC's specific written consent.

TRINAMIC products are not designed nor intended for use in military or aerospace applications or environments or in automotive applications unless specifically designated for such use by TRINAMIC. TRINAMIC conveys no patent, copyright, mask work right or other trade mark right to this product. TRINAMIC assumes no liability for any patent and/or other trade mark rights of a third party resulting from processing or handling of the product and/or any other use of the product.

16.7 Collateral Documents & Tools

This product documentation is related and/or associated with additional tool kits, firmware and other items, as provided on the product page at: www.trinamic.com.



17 Revision History

17.1 Hardware Revision

Version	Date	Author	Description
V1.0	2017-OCT-30	GE	Initial version
V1.1	2018-FEB-21	GE	Linear pre-regulator for driver supply added for better heat distribution on the pcb

Table 17: Hardware Revision

17.2 Document Revision

Version	Date	Author	Description
1.00	2018-MAR-29	GE	Initial version based on TMCM-1260 hardware manual
1.10	2018-APR-30	GE	Motor current settings updated. Max. motor current limited to 3A RMS for PANdrive™ versions.
1.20	2019-MAR-22	SK	PD86-3-1260 as additional PANdrive™ using TMCM-1260 added.
1.30	2019-DEC-06	GE	I/O Connector pin assignment corrected.
1.31	2021-AUG-18	OK	New block diagram.

Table 18: Document Revision

