

GBU4B Thru GBU4M

High Current Glass Passivated Molding Single-Phase Bridge Rectifier

Reverse Voltage 100 to 1000V Forward Current 4A

FEATURES

- Plastic Package has Underwriters Laboratory Flammability Classification 94V-0
- High current capacity with small package
- Glass passivated chip junctions
- Superior thermal conductivity
- High IFSM



1. Maximum & Thermal Characteristics Ratings at 25°C ambient temperature unless otherwise specified.

Parameter Symbol	Symbol	GBU4B	GBU4D	GBU4G	GBU4J	GBU4K	GBU4M	Unit
Maximum repetitive voltage	VRRM	100	200	400	600	800	1000	V
Maximum RMS Voltage	VRMS	70	140	280	420	560	700	V
Maximum non-repetitive voltage	VDC	110	220	440	660	880	1100	V
Maximum DC Blocking Voltage	VDC	100	200	400	600	800	1000	V
Maximum DC reverse current TA=25 °C	IR	5						μA
at rated DC blocking voltage TA=125°C		500						
Maximum average forward rectified output current at Tc=100°C ⁽¹⁾	Io	4						A
Unites mounted on P.C.B. without heat-sink Ta=40°C ⁽²⁾		3						
Peak forward surge current 8.3ms single half sine-wave superimposed on rated load	IFSM	150						A
Rating of fusing (t<8.3ms)	I ² t	93						A ² sec
Dielectric strength terminals to case, AC 1 minute Current 1mA	Vdia	2.5						KV
Max instantaneous forward voltage at 2.0A	VF	1.05						V
Maximum thermal on P.C.B. without heat-sink	R _{θJA}	MAX 22						°C/W
resistance per leg on Al plate heat-sink	R _{θJC}	MAX 3.5						
Operating junction temperature	TJ	-55~150						°C
Storage temperature	Tstg	-55~150						°C
Mounting torque	Tor	Rating Torque : 0.8 (Suggests 0.45~0.65)						N.m

GBU4B Thru GBU4M

2. Ratings and Characteristic Curves (TA = 25°C unless otherwise noted)

Fig. 1 Derating Curve

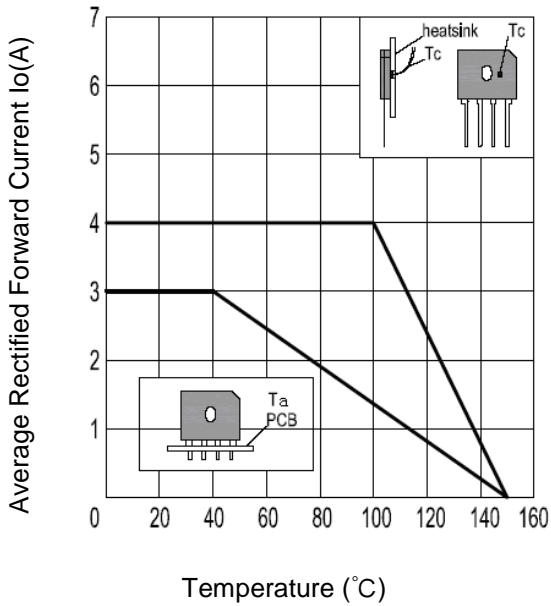

Fig.2 Typical Reverse Characteristics

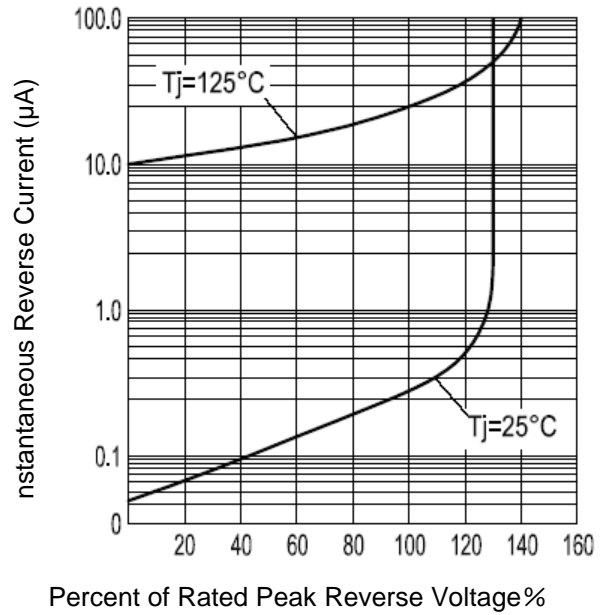

Fig.3 Forward Voltage

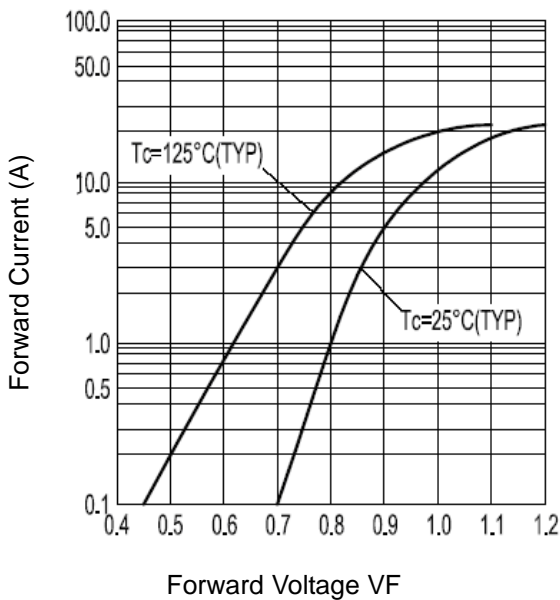
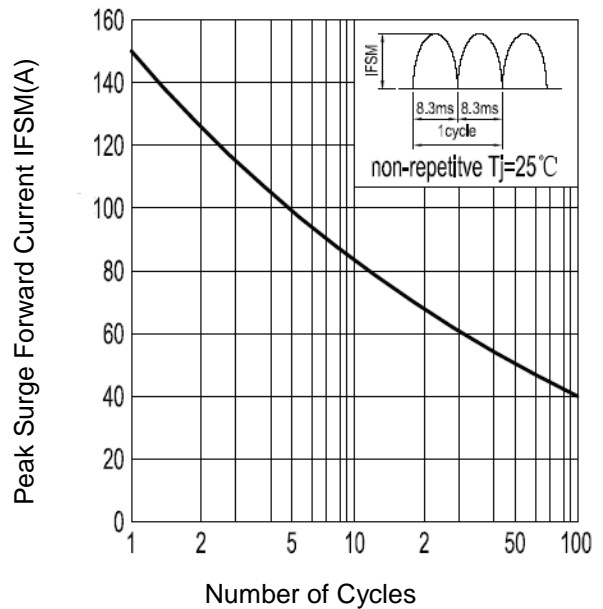
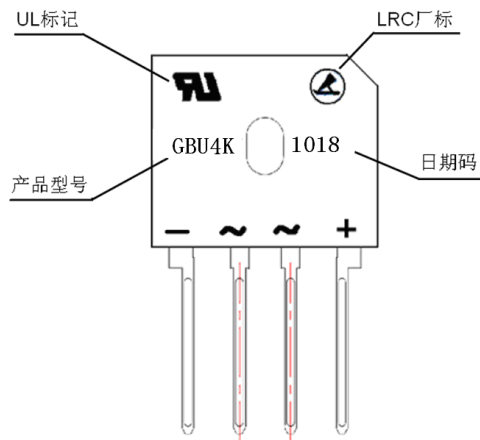

Fig.4 Peak Surge Forward Capability



GBU4B Thru GBU4M

3. Marking Identification



Note:

生产日期码包含4位数字，例如“1018”，前两个数字“10”表示为2010年，另外二个数字“18”是指第18周，即表示该产品为2010年18周生产。

型号:

GBU

4

K

bridge reverse voltage=800V

average rectified forward Current=4A

mean: GBU series bridge

4. Dimension

