

Certificate	No:
CQC	CQC15001131387
VDE,ENEC	40043123
KC	SU02089-15002
UL , cUL	E473864

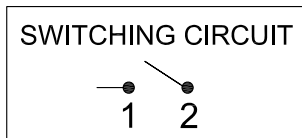

**Technical requirements:**

- Rating : CQC: 16A 125/250V~  
12(4) A 125/250V~  
VDE,ENEC,KC: 12(4) A 250V~  
UL , cUL : 16 A 125V~  
12(6) A 125/250V~  
1/2HP 125/250V~
- Operating force: 650±350gf
- Contact resistance: ≤50mΩ
- Electrical life: ≥10000 cycles
- Withstand Voltage :Between all terminals:  
1500VAC (50-60Hz) 5s  
Terminals to Button:  
3000V AC (50-60Hz) 5s  
Leakage Current : 5mA
- Insulation Resistance : ≥100MΩ 500V DC
- Environmental temperature: : -25~+125°C

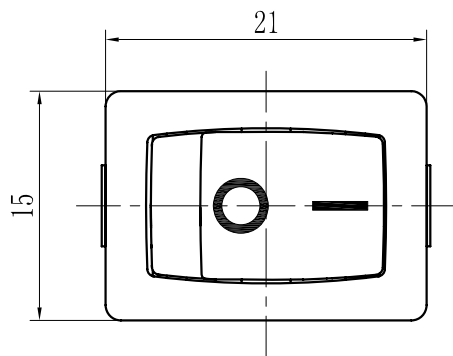
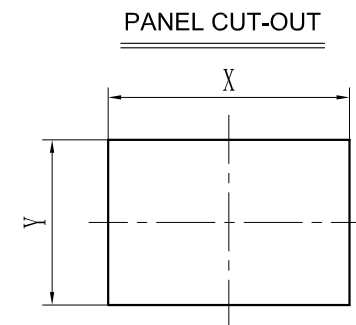
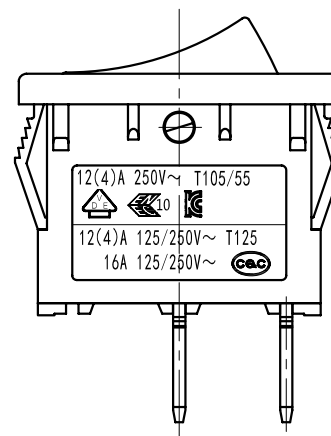
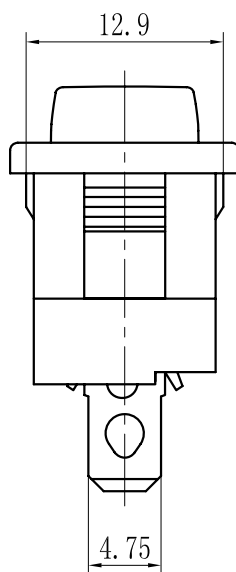
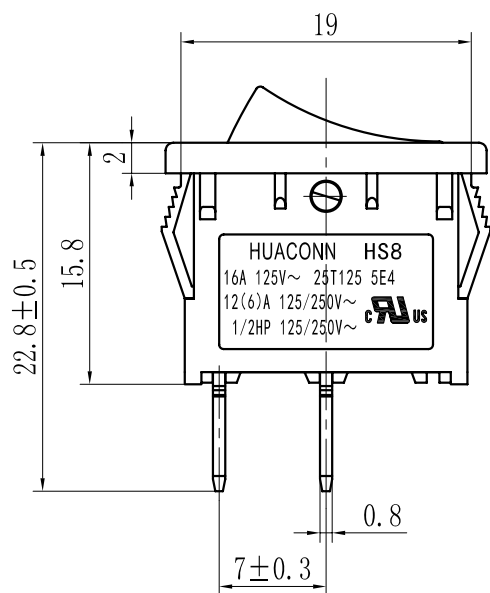

PANEL THICKNESS	DIM.X	DIM.Y
0.75~1.25	19.0~19.2	13.0
1.25~2.0	19.3~19.5	13.0
2.0~3.0	19.6~19.8	13.0

UNIT单位: mm

COMMON TOLERANCE 普通公差	ISSUE版本	DATE日期	DESCRIPTIONS修改	APPD.核准	PRODUCT NAME 产品名称: Rocker switch	DWN. 绘制: 胡新旺	DATE日期: 2016.01.09
	A	2016/01/09			PART NO. 料号: HS8-F3-8-01Q100-BB03	CHK'D审核: <i>[Signature]</i>	DATE日期: 2016.01.09
0~10 ±0.1; 10~20 ±0.2; 20~50 ±0.3; 50~ ±0.5;					PRODUCT MODEL 型号: HS8	APPD.核准: <i>[Signature]</i>	DATE日期: 2016.01.09
		SCALE比例: FREE	华琴电子有限公司 HUACONN ELECTRONICS CO.,LTD			Figure No. 图号	
						HS8F3C1002	