

SM5150BF thru SM5200BF

Schottky Barrier Rectifiers

Reverse Voltage 150 & 200V Forward Current 5.0A

FEATURES

- * Plastic package has Underwriters Laboratory Flammability Classification 94V-0
- * Low power loss,high efficiency
- * For use in low voltage high frequency inverters, free wheeling,and polarity protection applications
- * Guardring for over voltage protection
- * High temperature soldering guaranteed: 260°C/10 seconds at terminals

Mechanical Data

Case: JEDEC SMB-FL

molded plastic over glass die

Terminals: Plated leads, solderable per MIL-STD-750, Method 2026

Polarity: Color band denotes cathode end

Mounting Position: Any

Weight: 0.066 g

Handling precaution:None

Electrical Characteristic

1.Maximum Ratings & Thermal Characteristics Ratings at 25°C ambient temperature unless otherwise specified.

Parameter Symbol	symbol	SM5150BF	SM5200BF	Unit
device marking code		S515	S520	
Maximum repetitive peak reverse voltage	V_{RRM}	150	200	V
Maximum RSM voltage	V_{RSM}	105	140	V
Maximum DC blocking voltage	V_{DC}	150	200	V
Maximum average forward rectified current lead length at TC = 75°C	$I_F(AV)$	5.0		A
Peak forward surge current 8.3ms single half sine-wave superimposed on rated load (JEDEC Method)	I_{FSM}	100		A
Typical thermal resistance (Note1)	$R_{\theta JA}$ $R_{\theta JC}$	135 25		°C/W
Operating junction and storage temperature range	T_J , T_{STG}	-40 to +150		°C

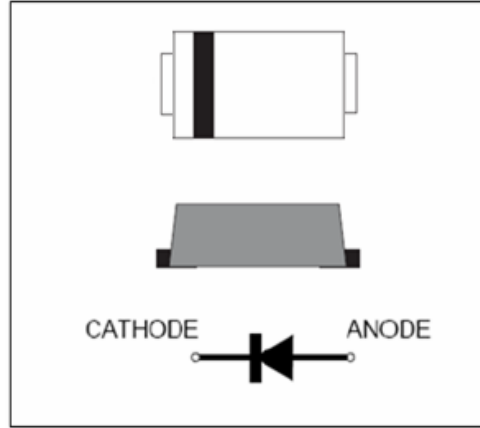

we declare that the material of product is halogen free (green epoxy compound).

Electrical Characteristics Ratings at 25°C ambient temperature unless otherwise specified.

Parameter Symbol	symbol	SM5150BF	SM5200BF	Unit
Maximum instantaneous forward voltage at 5.0A	V_F	0.87		V
Maximum DC reverse current $T_A = 25^\circ\text{C}$ at rated DC blocking voltage $T_J = 125^\circ\text{C}$	I_R	0.1 10.0		mA
Typical junction capacitance at 4.0V, 1MHz	C_J	110		PF

NOTES:

1. 8.0mm² (.013mm thick) land areas

SM5150BF thru SM5200BF

2. Ratings and Characteristic Curves (TA = 25°C unless otherwise noted)

Fig. 1 - Forward Current Derating Curve

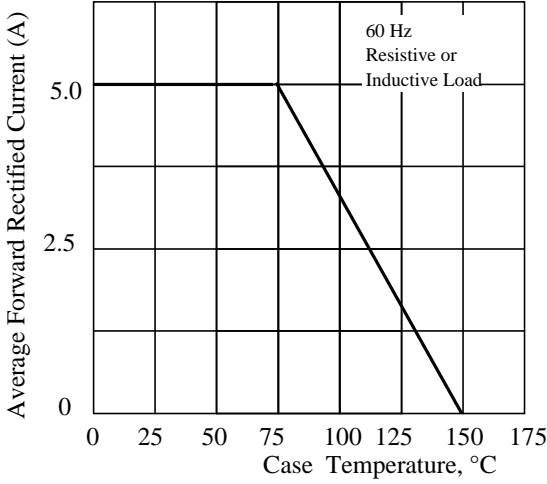

Fig. 2 - Maximum Non-repetitive Peak Forward Surge Current

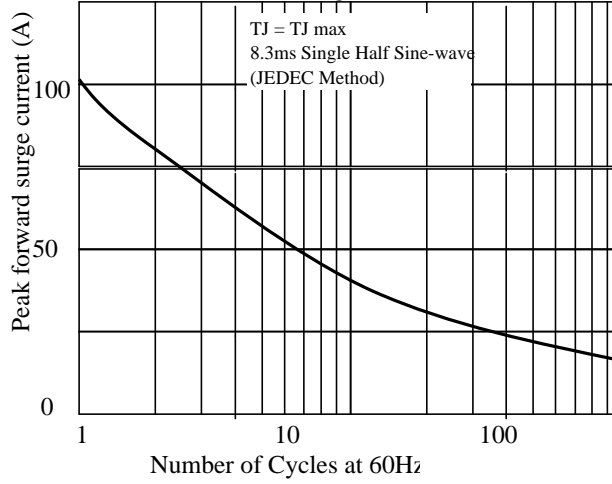

Fig 3. - Typical Instantaneous Forward Characteristics

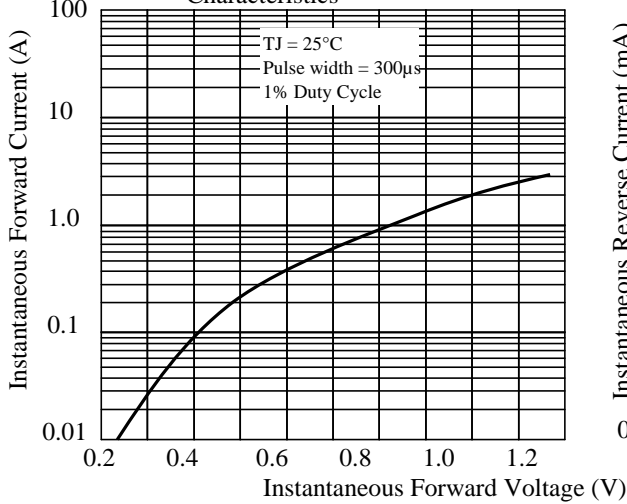

Fig 4. - Typical Reverse Characteristics

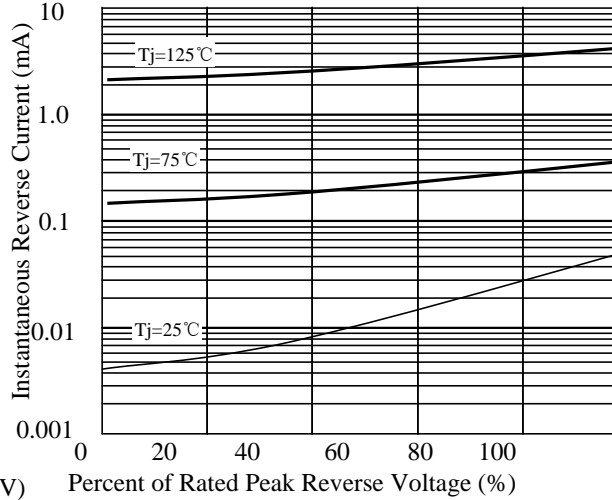

Fig 5. - typical transient thermal impedance

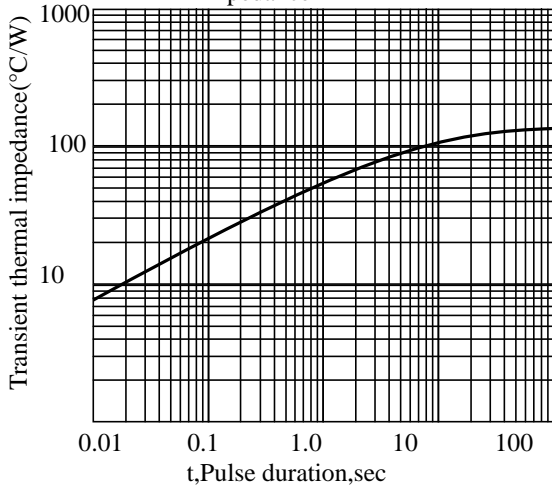
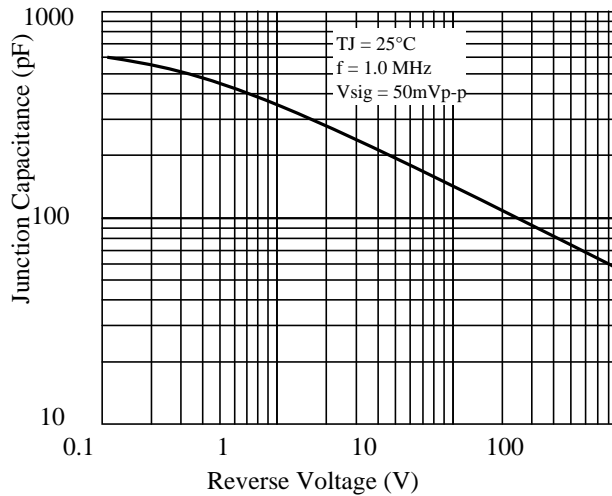

Fig 6. - Typical Junction Capacitance



SM5150BF thru SM5200BF

3. dimension:

SMB-FL

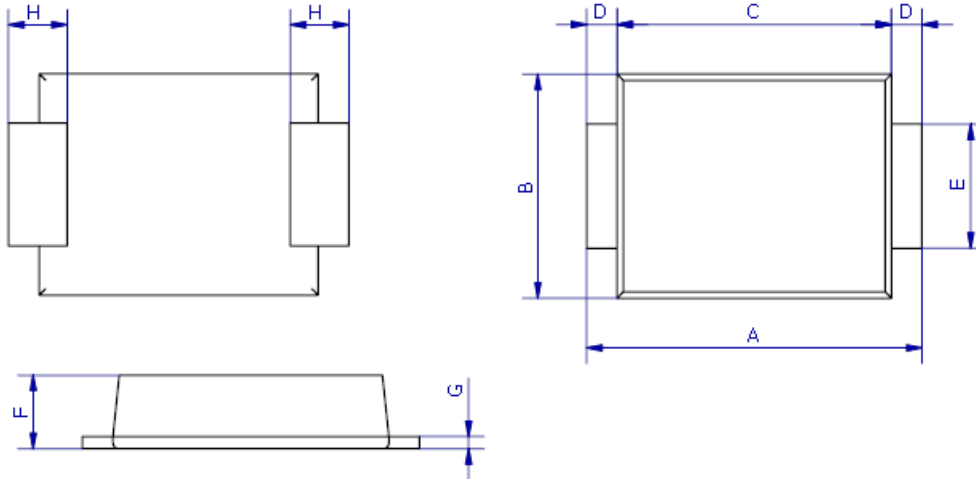

DIM	MILLIMETERS		INCHES	
	MIN	MAX	MIN	MAX
A	5.3	5.7	0.209	0.224
B	3.4	3.8	0.134	0.150
C	4.3	4.7	0.169	0.185
D	0.45Typ		0.018Typ	
E	1.9	2.1	0.0748	0.08268
F	1.05	1.40	0.04134	0.05512
G	0.2	0.3	0.00591	0.00984
H	0.95Typ		0.037Typ	

Mounting Pad Layout

--- SMB-FL

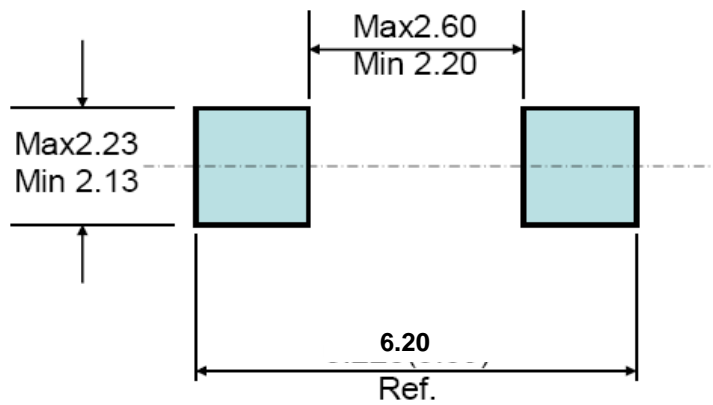

5.1 、 SMD Packing Reel Spec & Packing Quantity

5.1.1 Reel Packing

A. Reel Spec



unit: mm

SPEC	A	B	C	W	Quantity/Reel
SMA-FL 7" reel	177.0±2.0	54.0±0.5	13.0±0.5	13.2±0.2	3K
TO277 13" reel	330.0±2.0	75.0±0.5	13.0±0.5	13.2±0.2	5K
SOD123FL 7" reel	177.0±2.0	50.0±0.5	13.0±0.5	9.4±1.5	3K
SOD323HE 7" reel	177.0±2.0	50.0±0.5	13.0±0.5	9.4±1.5	3K
SMB-FL 13" reel	330.0±2.0	75.0±0.5	13.0±0.5	13.2±0.2	5K

B. 13" reel packing box



unit: mm

size	A	B	C
	335±5.0	335±2.0	40±1.0

as per above packing

Spec	Q' ty/Box
TO277 13" reel	10K
SMB-FL 13" reel	10K

C. 7" reel packing box

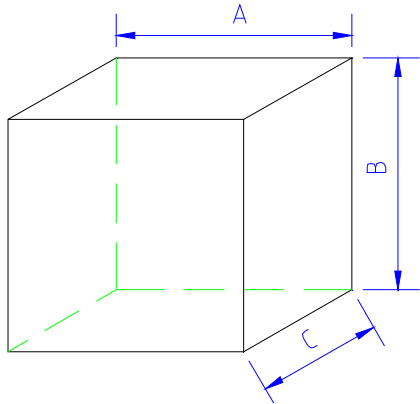

unit: mm

	A	B	C
SMA-FL			
SOD123FL			
SOD323HE	186±2.0	139±2.0	185±2.0

as per above packing

	Q' ty/Box
SMA-FL	30K
SOD123FL	30K
SOD323HE	30K

D. reel packing carton

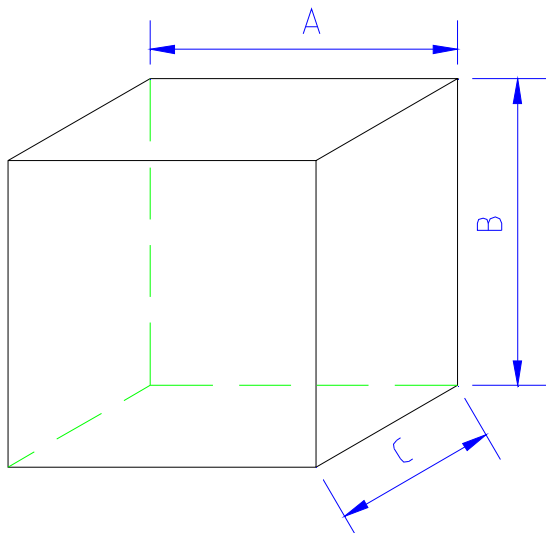

unit: mm

	A	B	C
size	350±2.0	340±2.0	350±2.0

as per above packing

Spec	Q' ty/Carton
TO277 13" reel	80K
SMB-FL 13" reel	80K

unit: mm

	A	B	C
SMA-FL			
SOD123FL			
SOD323HE	455±2.0	400±2.0	410±2.0

as per above packing

Spec	Q' ty/Carton
SMA-FL 7" reel	360K
SOD123-FL 7" reel	360K
SOD323HE 7" reel	360K

5.1.2 Tape Spec

A. Cover Tape

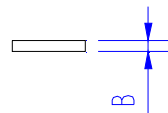

unit: mm

	A	B
SMA-FL	9.5±0.10	0.062±0.007
SMB-FL		
TO277		
SOD123FL	5.4±0.10	
SOD323HE		

B. Carrier Tape

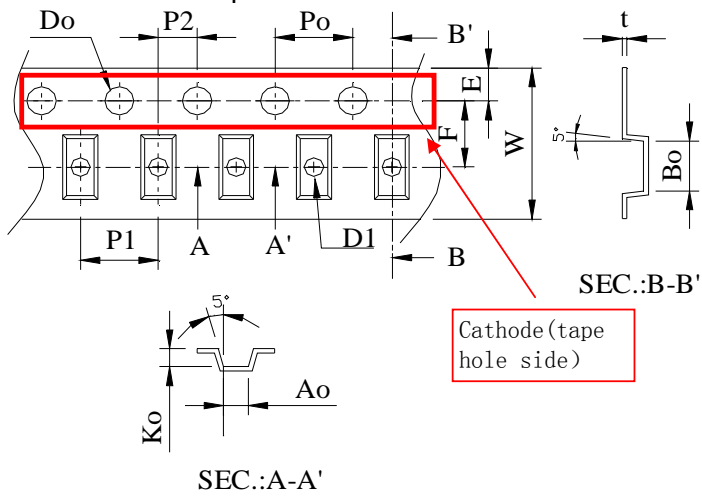

Item	SOD323HE	SOD123FL	SMA-FL	SMB-FL	TO277
W	8±0.3	8±0.3	12±0.3	12±0.3	12±0.3
P1	4±0.1	4±0.1	4±0.1	8±0.1	8±0.1
E	1.75±0.1	1.75±0.1	1.75±0.1	1.75±0.1	1.75±0.1
F	3.5±0.05	3.5±0.05	5.5±0.05	5.5±0.05	5.5±0.05
D0	1.55±0.05	1.55±0.05	1.55±0.05	1.55±0.05	1.55±0.05
D1	1.1±0.1	1.1±0.1	1.5±0.1	1.55±0.05	1.5±0.1
P0	4±0.1	4±0.1	4±0.1	4±0.1	4±0.1
P2	2±0.05	2±0.05	2±0.05	2±0.05	2±0.05
10P0	40±0.2	40±0.2	40±0.2	40±0.2	40±0.2
A0	1.45±0.1	1.95±0.1	2.83±0.1	3.8±0.1	4.3±0.1
B0	2.75±0.1	3.95±0.1	4.75±0.1	5.75±0.1	6.8±0.1
K0	0.80±0.1	1.30±0.1	1.42±0.1	1.4±0.1	1.35±0.1
T	0.25±0.05	0.25±0.05	0.25±0.05	0.25±0.05	0.25±0.05

Title:

Power Diode SMD Package Packing Spec

DOC NO.: WI-258

Version: 5 Modification: 0

Page: 5

5.2、SMD Power Diode General Packing Spec

A. 7" reel

all labels will be at cathode side of reel ;

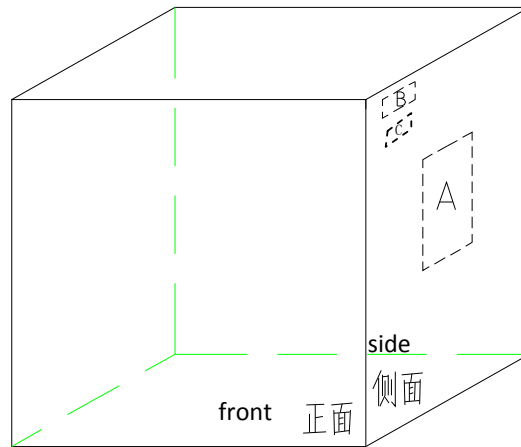
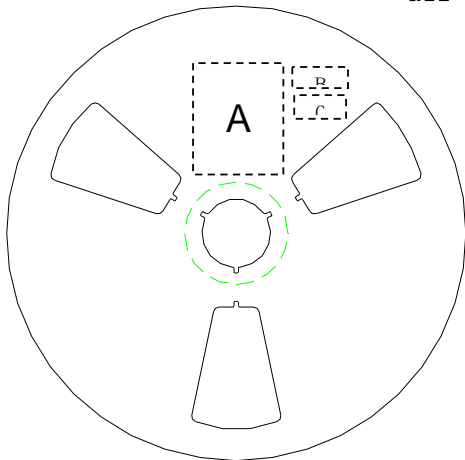

A:LRC label;

B:Environment Label C:Halide free label

B. 13" reel

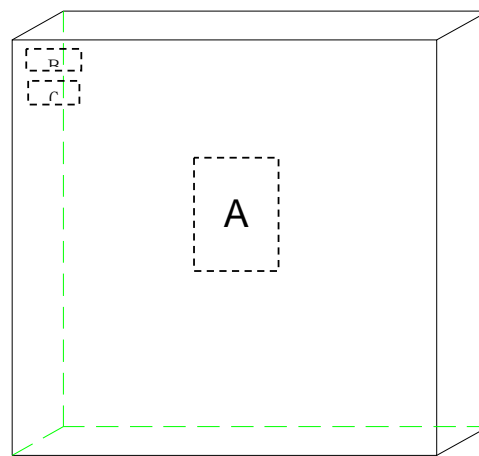
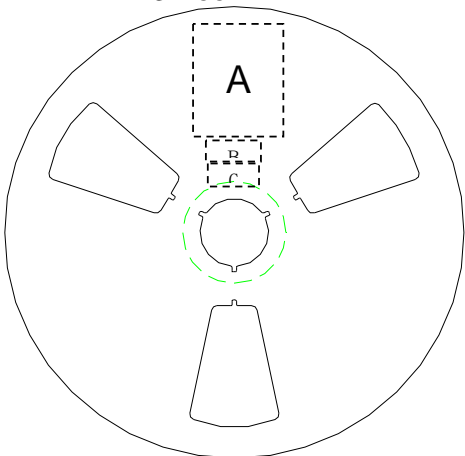

A:LRC label;

B:Environment Labe C:Halide free label

C. Tape lead: face anode side of the reel, upper side is the tape lead position. All labels are at cathode side of the reel.



标题: Power Diode SMD Package Packing Spec	DOC NO.: WI-258
	Version: 5 Modification: 0
	Page: 6

C. Label Content :
LRC Label

P/N → (1P) LPN: **SM140A**
 Lot No. → (1T) LOT: **140106049X**
 Date code → (9D) DTE: **1403**
 Quantity → (Q) QTY: **10000**

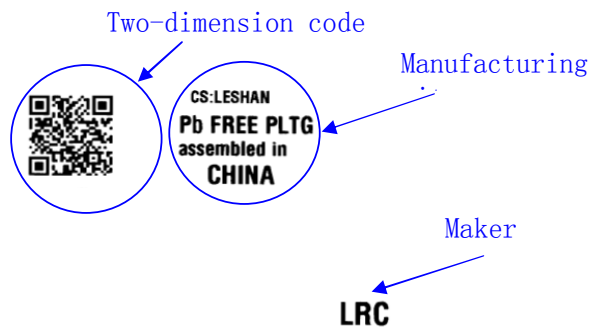

lot: 140106049X: 140106---2014/1/6; 049----lot number:49; X: product code

Environment Label



Halide-free Label



SM5150BF thru SM5200BF

4. Update Record

版次	更新记录	更新作者	更新日期
1	第一版	周杰	2014.05.19