

TO-220-3L Plastic-Encapsulate MOSFETS

IRF640 MOSFET(N-Channel)

FEATURE

- Dynamic dv/dt Rating
- Repetitive Avalanche Rated
- Fast Switching
- Ease of Paralleling
- Simple Drive Requirement

DESCRIPTION

Third Generation HEXFETs from international Rectifier provide the designer with the best combination of fast switching ,ruggedized device design,low on-resistance and cost effectiveness.

The TO-220-3L package is universally preferred for all commercial-industrial applications at power dissipation levels to approximately 50 watts. The low thermal resistance and low package cost of the TO-220-3L contribute to its wide acceptance throughout the industry.

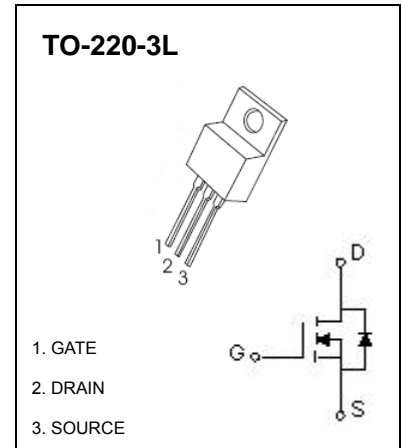

MAXIMUM RATINGS($T_a=25^{\circ}\text{C}$ unless otherwise noted)

Symbol	Parameter	Value	Units
I_D	Continuous Drain Current, V_{GS} @ 10 V	18	A
P_D	Power Dissipation	2	W
	Linear Derating Factor	1.0	W/ $^{\circ}\text{C}$
V_{GS}	Gate-Source Voltage	± 20	V
E_{AS}	Single Pulse Avalanche Energy (note 1)	580	mJ
$R_{\theta JA}$	Thermal Resistance from Junction to Ambient	62.5	$^{\circ}\text{C}/\text{W}$
T_J	Junction Temperature	150	$^{\circ}\text{C}$
T_{STG}	Storage Temperature	-55~+150	$^{\circ}\text{C}$

ELECTRICAL CHARACTERISTICS (T_a=25°C unless otherwise specified)

Parameter	Symbol	Test conditions	Min	Typ	Max	Unit
Drain-source breakdown voltage	V _{(BR)DSS}	V _{GS} =0V, I _D =250μA	200			V
Gate-threshold voltage	V _{(GS)th}	V _{DS} =V _{GS} , I _D =250μA	2		4	
Gate-body leakage	I _{GSS}	V _{DS} =0V, V _{GS} =±20V			±100	nA
Zero gate voltage drain current	I _{DSS}	V _{DS} =200V, V _{GS} =0V			25	μA
Drain-source on-resistance (note 2)	R _{DS(on)}	V _{GS} =10V, I _D =11A			0.18	Ω
Forward transconductance (note 2)	g _{fs}	V _{DS} =50V, I _D =11A	6.7			S
Diode forward voltage (note 2)	V _{SD}	I _S =18A, V _{GS} =0V			2	V
Input capacitance (note 3)	C _{iss}	V _{DS} =25V, V _{GS} =0V, f=1MHz		1300		pF
Output capacitance (note 3)	C _{oss}			430		
Reverse transfer capacitance (note 3)	C _{rss}			130		
Turn-on time(note 2,3)	t _{d(on)}	V _{DD} =100V, R _D =5.4Ω, I _D =18A, R _G =9.1Ω		14		ns
Rise time	t _r			51		
Turn-off time (note 2,3)	t _{d(off)}			45		
Fall time (note 2,3)	t _f			36		

Notes:

1. V_{DD}=50V, starting T_J=25°C, L=2.7mH, R_G=25Ω, I_{AS}=18A.
2. Pulse test: Pulse width≤300μs, duty cycle≤2%.
3. These parameters have no way to verify.

Typical Characteristics

IRF640

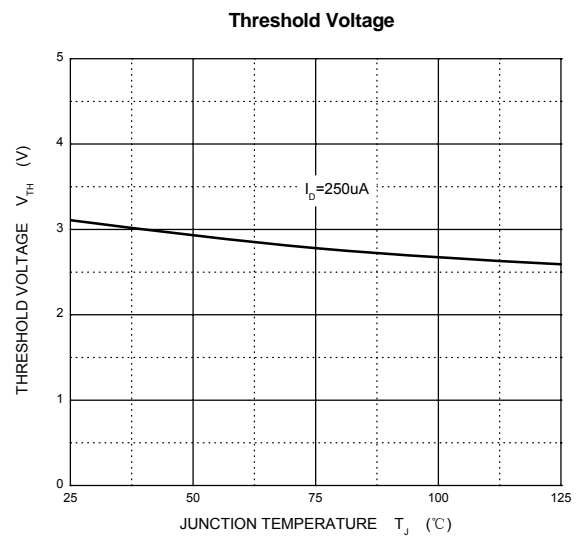
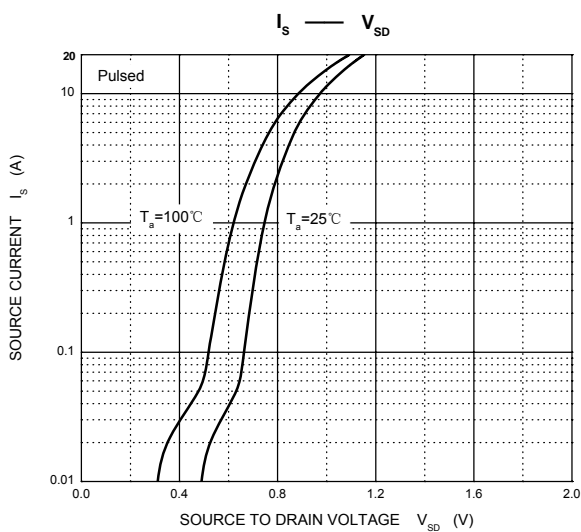
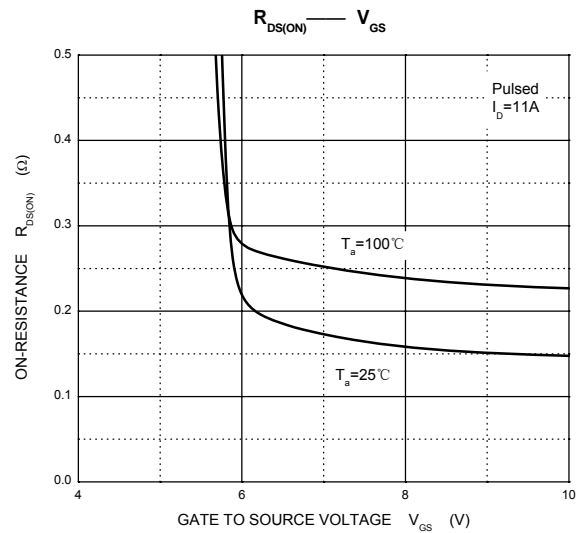
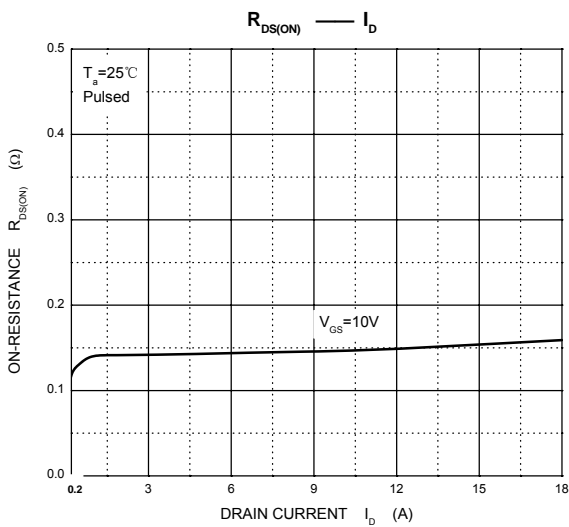
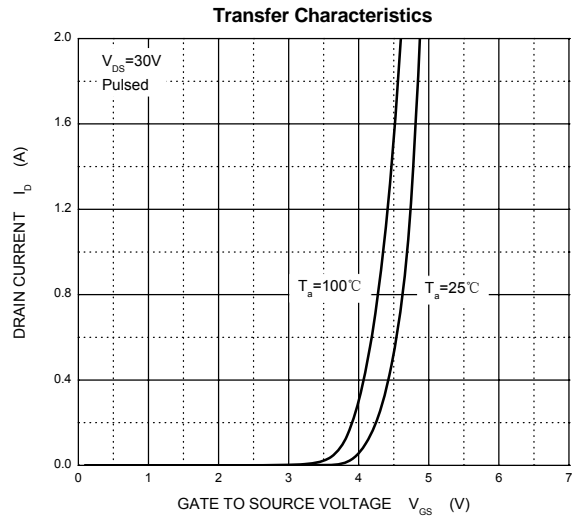
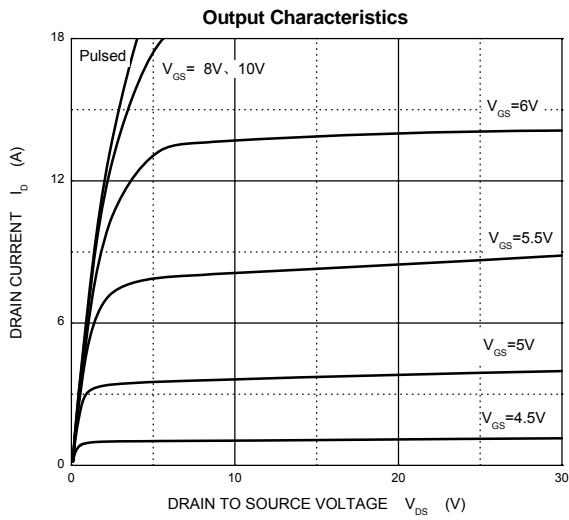

TO-220-3L Package Outline Dimensions

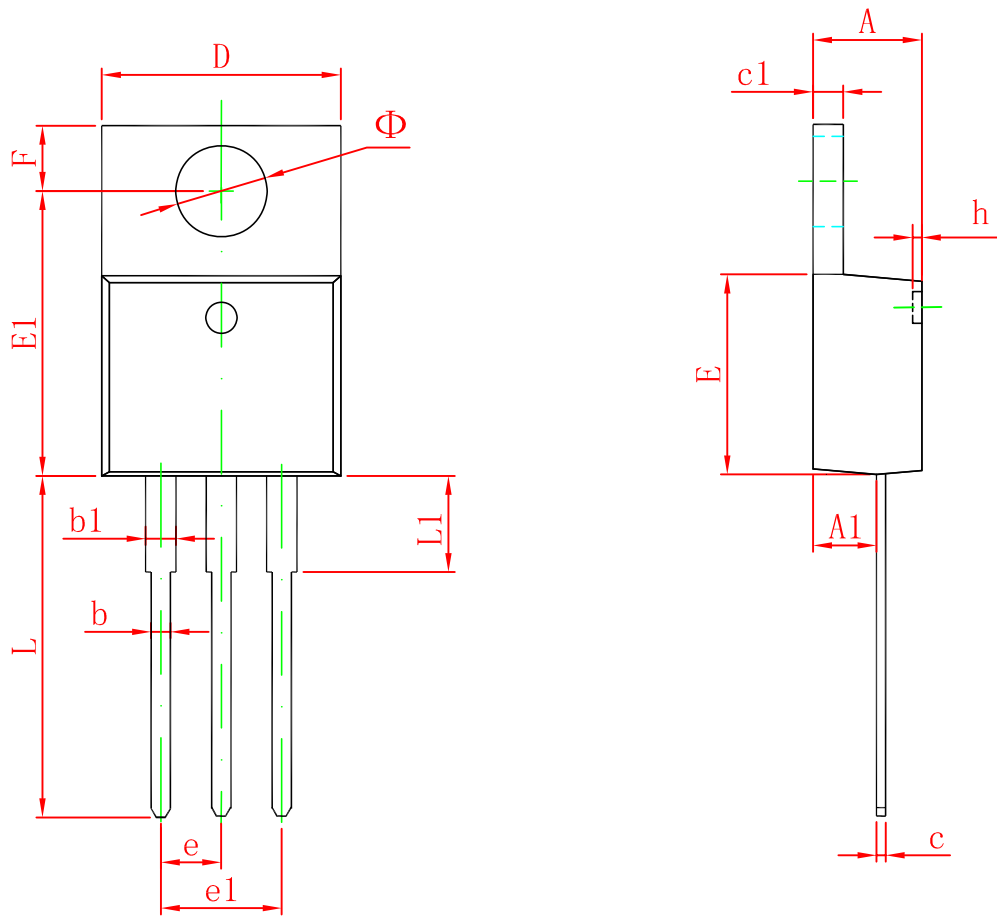

Symbol	Dimensions In Millimeters		Dimensions In Inches	
	Min	Max	Min	Max
A	4.470	4.670	0.176	0.184
A1	2.520	2.820	0.099	0.111
b	0.710	0.910	0.028	0.036
b1	1.170	1.370	0.046	0.054
c	0.310	0.530	0.012	0.021
c1	1.170	1.370	0.046	0.054
D	10.010	10.310	0.394	0.406
E	8.500	8.900	0.335	0.350
E1	12.060	12.460	0.475	0.491
e	2.540 TYP		0.100 TYP	
e1	4.980	5.180	0.196	0.204
F	2.590	2.890	0.102	0.114
h	0.000	0.300	0.000	0.012
L	13.400	13.800	0.528	0.543
L1	3.560	3.960	0.140	0.156
Φ	3.735	3.935	0.147	0.155