

## TO-92 Plastic-Encapsulate Transistors

**2N4401** TRANSISTOR (NPN)

**FEATURES**

Power dissipation

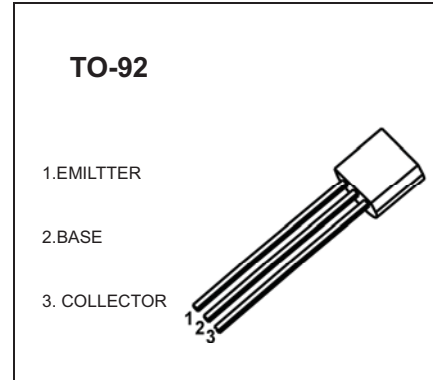

**MARKING**

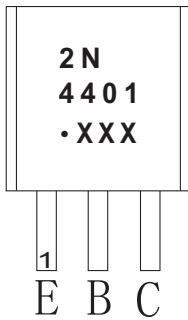

2N4401=Device code  
Solid dot=Green molding compound device,  
if none,the normal device  
XXX=Code

**Equivalent Circuit**

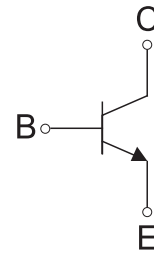

**ORDERING INFORMATION**

Part Number	Package	Packing Method	Pack Quantity
2N4401	TO-92	Bulk	1000pcs/Bag
2N4401-TA	TO-92	Tape	2000pcs/Box

**MAXIMUM RATINGS (T<sub>a</sub>=25°C unless otherwise noted)**

Symbol	Parameter	Value	Unit
V <sub>CB0</sub>	Collector-Base Voltage	60	V
V <sub>CE0</sub>	Collector-Emitter Voltage	40	V
V <sub>EB0</sub>	Emitter-Base Voltage	6	V
I <sub>c</sub>	Collector Current -Continuous	600	mA
P <sub>c</sub>	Collector Power dissipation	0.625	W
T <sub>J</sub>	Junction Temperature	150	°C
T <sub>stg</sub>	Storage Temperature	-55 ~ +150	°C
R <sub>θJA</sub>	Thermal Resistance, junction to Ambient	357	°C/mW

## ELECTRICAL CHARACTERISTICS

$T_a=25^\circ\text{C}$  unless otherwise specified

Parameter	Symbol	Test conditions	Min	Max	Unit
Collector-base breakdown voltage	$V_{(BR)CBO}$	$I_C=100\mu\text{A}$ , $I_E=0$	60		V
Collector-emitter breakdown voltage	$V_{(BR)CEO}$	$I_C=1\text{mA}$ , $I_B=0$	40		V
Emitter-base breakdown voltage	$V_{(BR)EBO}$	$I_E=100\mu\text{A}$ , $I_C=0$	6		V
Collector cut-off current	$I_{CBO}$	$V_{CB}=35\text{V}$ , $I_E=0$		0.1	$\mu\text{A}$
Emitter cut-off current	$I_{EBO}$	$V_{EB}=5\text{V}$ , $I_C=0$		0.1	$\mu\text{A}$
DC current gain	$h_{FE(1)}$	$V_{CE}=1\text{V}$ , $I_C=0.1\text{mA}$	20		
	$h_{FE(2)}$	$V_{CE}=1\text{V}$ , $I_C=1\text{mA}$	40		
	$h_{FE(3)}$	$V_{CE}=1\text{V}$ , $I_C=10\text{mA}$	80		
	$h_{FE(4)}$	$V_{CE}=1\text{V}$ , $I_C=150\text{mA}$	100	300	
	$h_{FE(5)}$	$V_{CE}=2\text{V}$ , $I_C=500\text{mA}$	40		
Collector-emitter saturation voltage	$V_{CE(sat)1}$	$I_C=150\text{mA}$ , $I_B=15\text{mA}$		0.4	V
	$V_{CE(sat)2}$	$I_C=500\text{mA}$ , $I_B=50\text{mA}$		0.75	V
Base-emitter saturation voltage	$V_{BE(sat)1}$	$I_C=150\text{mA}$ , $I_B=15\text{mA}$		0.95	V
	$V_{BE(sat)2}$	$I_C=500\text{mA}$ , $I_B=50\text{mA}$		1.2	V
Transition frequency	$f_T$	$V_{CE}=10\text{V}$ , $I_C=20\text{mA}$ , $f=100\text{MHz}$	250		MHz
Output Capacitance	$C_{ob}$	$V_{CB}=10\text{V}$ , $I_E=0$ , $f=100\text{KHz}$		6.5	pF
Delay time	$t_d$	$V_{CC}=30\text{V}$ , $V_{BE(OFF)}=2\text{V}$		15	ns
Rise time	$t_r$		$I_C=150\text{mA}$ , $I_{B1}=15\text{mA}$		20
Storage time	$t_s$	$V_{CC}=30\text{V}$ , $I_C=150\text{mA}$		225	ns
Fall time	$t_f$		$I_{B1}=-I_{B2}=15\text{mA}$		30

# Typical Characteristics

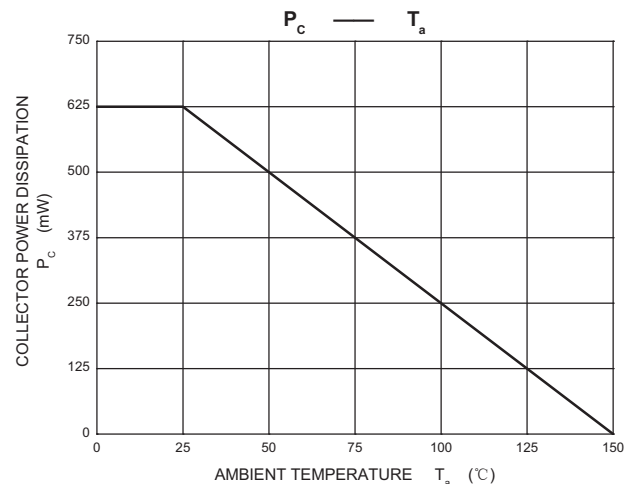
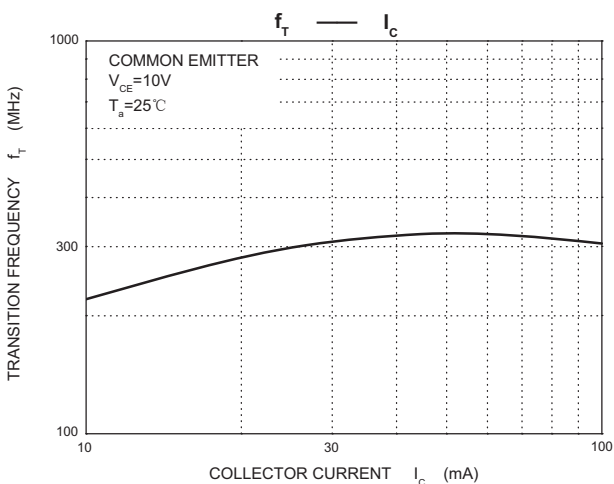
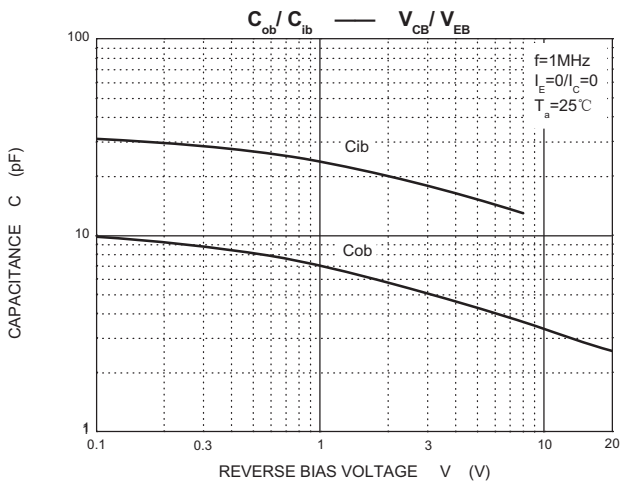
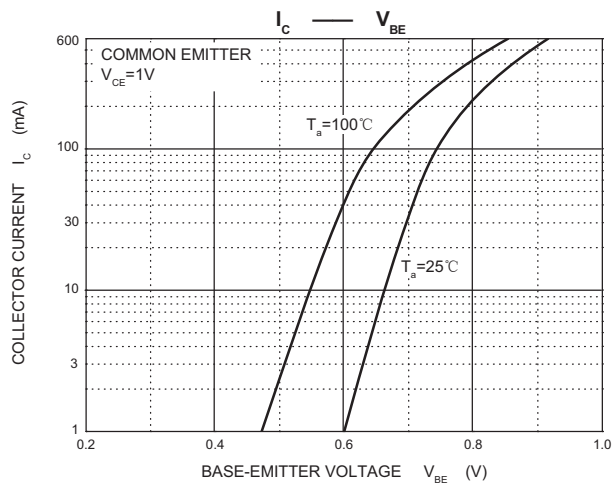
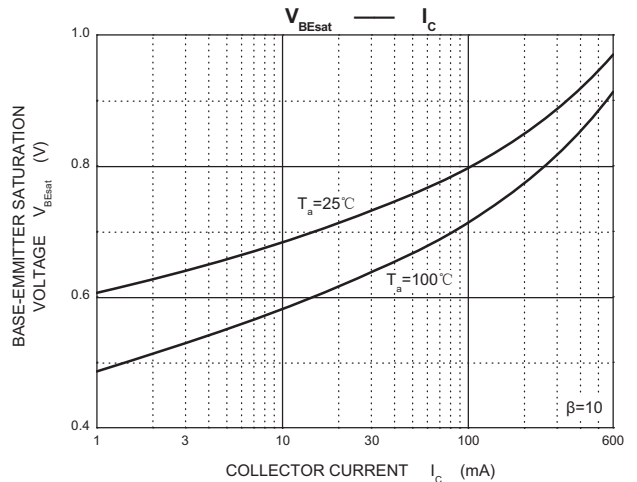
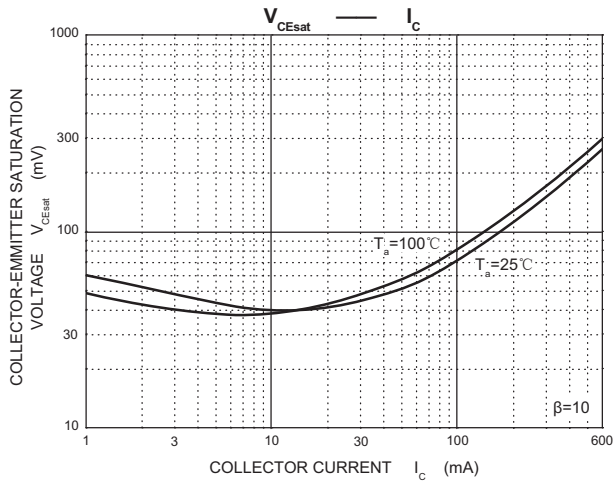
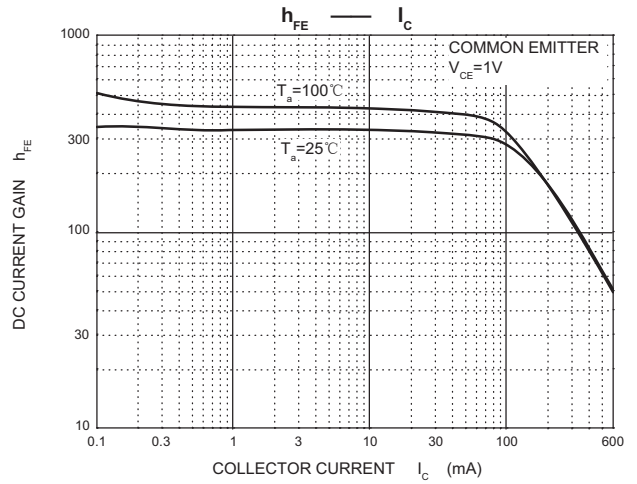
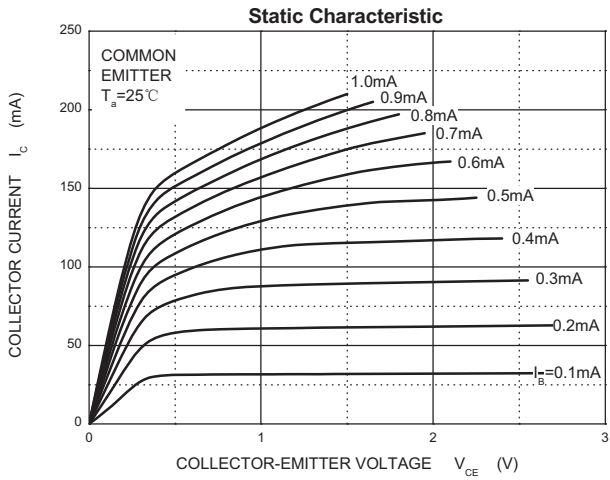

## TO-92 Package Outline Dimensions

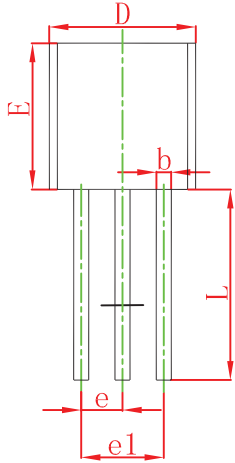
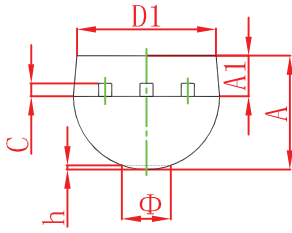

Symbol	Dimensions In Millimeters		Dimensions In Inches	
	Min	Max	Min	Max
A	3.300	3.700	0.130	0.146
A1	1.100	1.400	0.043	0.055
b	0.380	0.550	0.015	0.022
c	0.360	0.510	0.014	0.020
D	4.300	4.700	0.169	0.185
D1	3.430		0.135	
E	4.300	4.700	0.169	0.185
e	1.270 TYP		0.050 TYP	
e1	2.440	2.640	0.096	0.104
L	14.100	14.500	0.555	0.571
Φ		1.600		0.063
h	0.000	0.380	0.000	0.015

## TO-92 Suggested Pad Layout

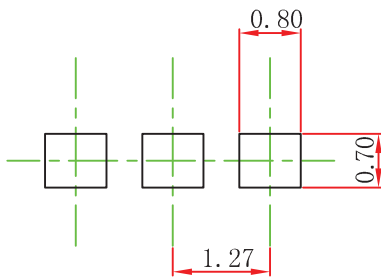

### Note:

1. Controlling dimension: in millimeters.
2. General tolerance:  $\pm 0.05$ mm.
3. The pad layout is for reference purposes only.

### NOTICE

JCET reserve the right to make modifications, enhancements, improvements, corrections or other changes without further notice to any product herein. JCET does not assume any liability arising out of the application or use of any product described herein.

TO-92 PACKAGE TAPEING DIMENSION

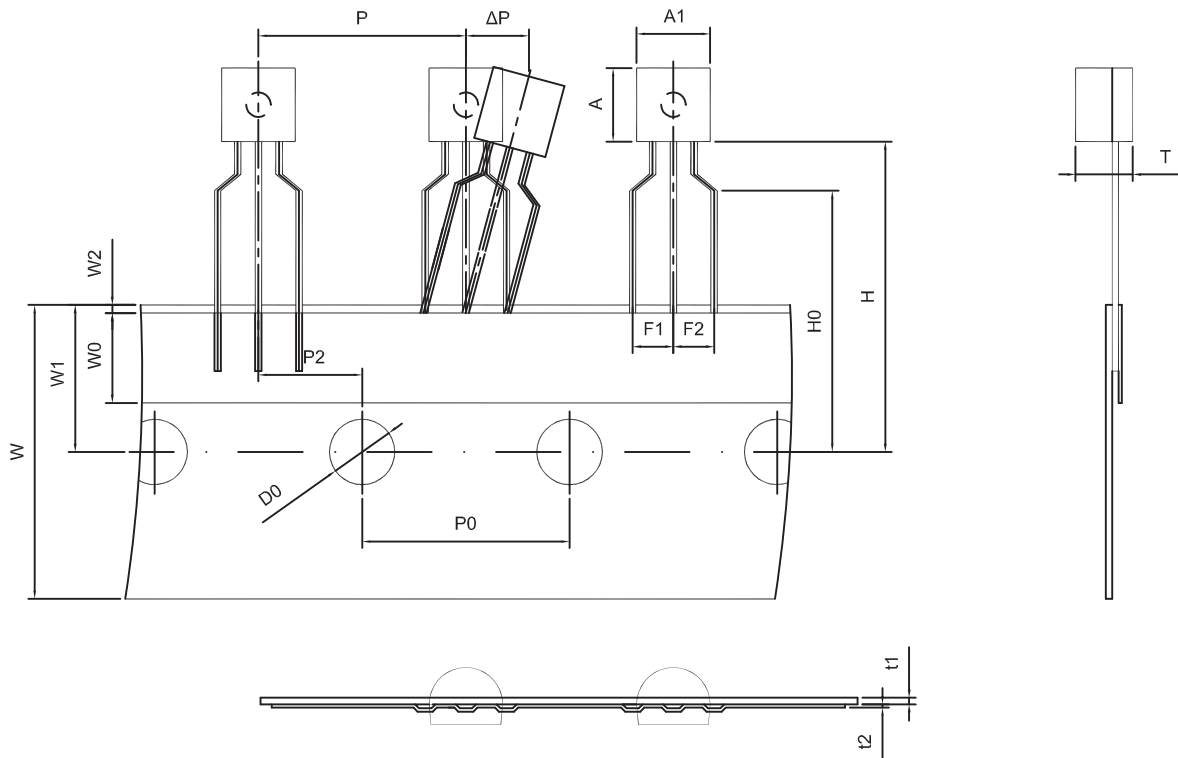

Dimiensions are in millimeter								
A1	A	T	P	P0	P2	F1	F2	W
4.5	4.5	3.5	12.7	12.7	6.35	2.5	2.5	18.0
W0	W1	W2	H	H0	D0	t1	t2	ΔP
6.0	9.0	1.0 MAX.	19.0	16.0	4.0	0.4	0.2	0

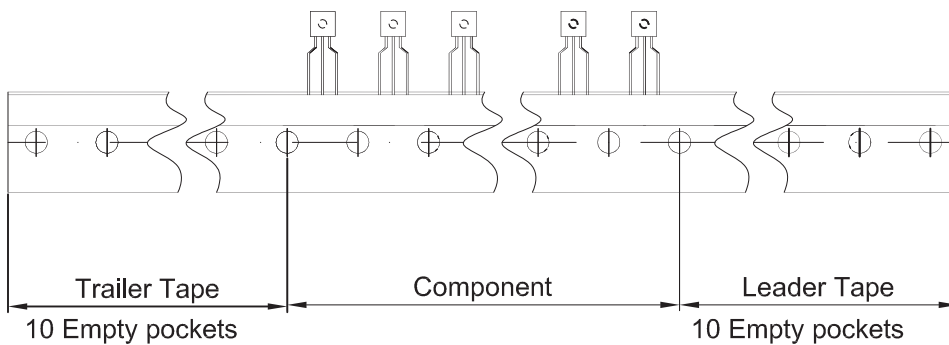

Package	Box	Box Size(mm)	Carton	Carton Size(mm)
TO-92	2000 pcs	333×162×43	20,000 pcs	350×340×250