

TO-220F Plastic-Encapsulate Diodes

MBR20100FCT, 150FCT, 200FCT

SCHOTTKY BARRIER RECTIFIER

FEATURES

- Schottky Barrier Chip
- Guard Ring Die Construction for Transient Protection
- Low Power Loss, High Efficiency
- High Surge Capability
- High Current Capability and Low Forward Voltage Drop
- For Use in Low Voltage, High Frequency Inverters, Free Wheeling, and Polarity Protection Applications

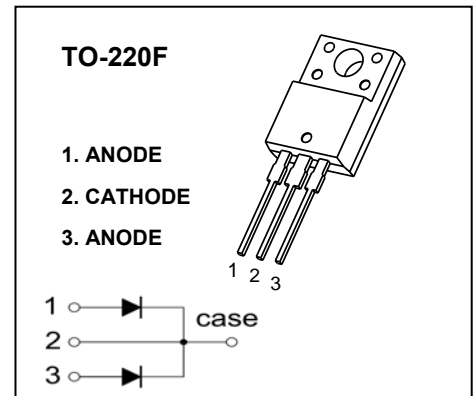

MAXIMUM RATINGS ($T_a=25^{\circ}\text{C}$ unless otherwise noted)

Symbol	Parameter	Value			Unit
		MBR20100FCT	MBR20150FCT	MBR20200FCT	
V_{RRM}	Peak repetitive reverse voltage	100	150	200	V
V_{RWM}	Working peak reverse voltage				
V_R	DC blocking voltage				
$V_{R(RMS)}$	RMS reverse voltage	70	105	140	V
I_O	Average rectified output current	20			A
I_{FSM}	Non-Repetitive peak forward surge current 8.3ms half sine wave	150			A
P_D	Power dissipation	2			W
$R_{\theta JA}$	Thermal resistance from junction to ambient	50			$^{\circ}\text{C}/\text{W}$
T_j	Junction temperature	125			$^{\circ}\text{C}$
T_{stg}	Storage temperature	-55~+150			$^{\circ}\text{C}$

ELECTRICAL CHARACTERISTICS ($T_a=25^{\circ}\text{C}$ unless otherwise specified)

Parameter	Symbol	Device	Test conditions	Min	Typ	Max	Unit
Reverse voltage	$V_{(BR)}$	MBR20100FCT	$I_R=1\text{mA}$	100			V
		MBR20150FCT		150			
		MBR20200FCT		200			
Reverse current	I_R	MBR20100FCT	$V_R=100\text{V}$			0.1	mA
		MBR20150FCT	$V_R=150\text{V}$			0.1	
		MBR20200FCT	$V_R=200\text{V}$			0.1	
Forward voltage	V_{F1}	MBR20100FCT	$I_F=10\text{A}$			1	V
		MBR20150FCT				1	
		MBR20200FCT				1	
	V_{F2}^*	MBR20100FCT	$I_F=20\text{A}$			1.2	V
		MBR20150FCT				1.2	
		MBR20200FCT				1.2	

*Pulst test

Typical Characteristics

Forward Characteristics

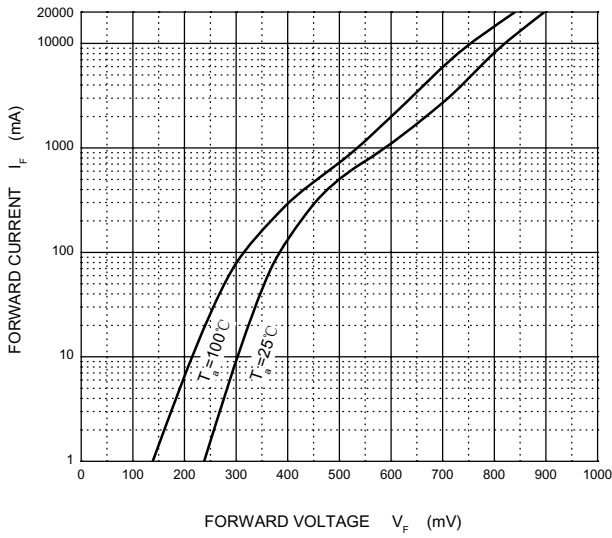

Reverse Characteristics

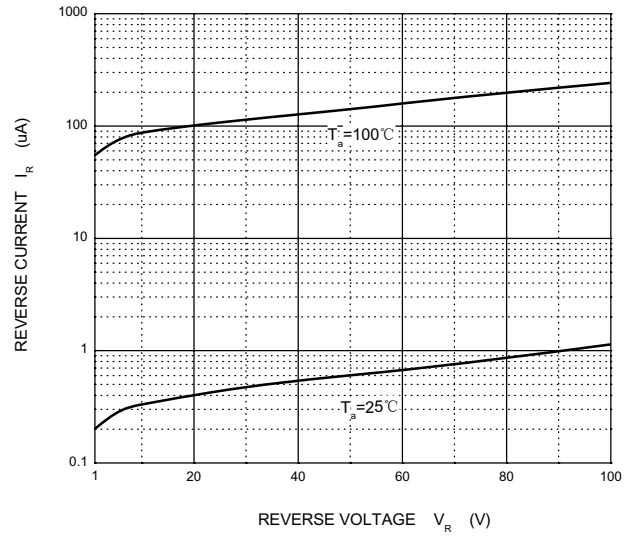

Capacitance Characteristics

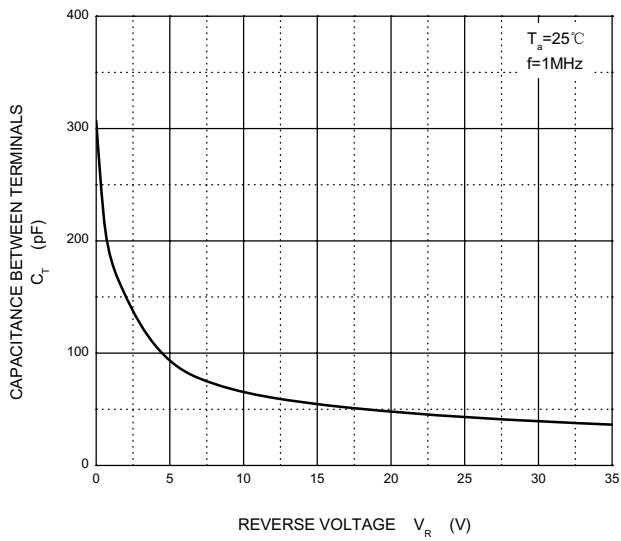

Power Derating Curve

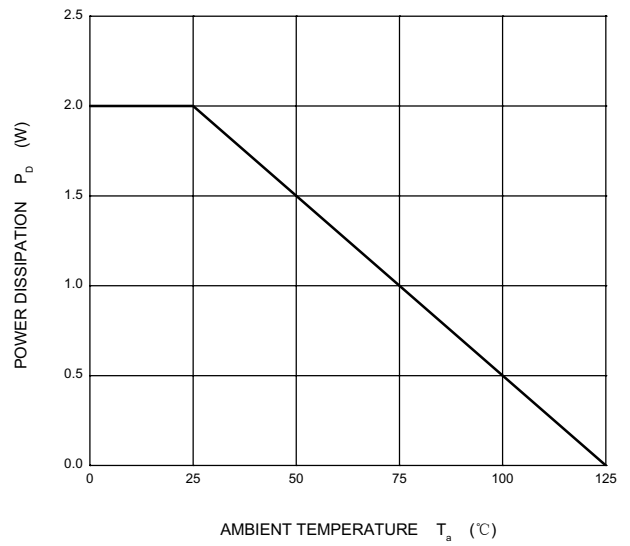

TO-220F Package Outline Dimensions

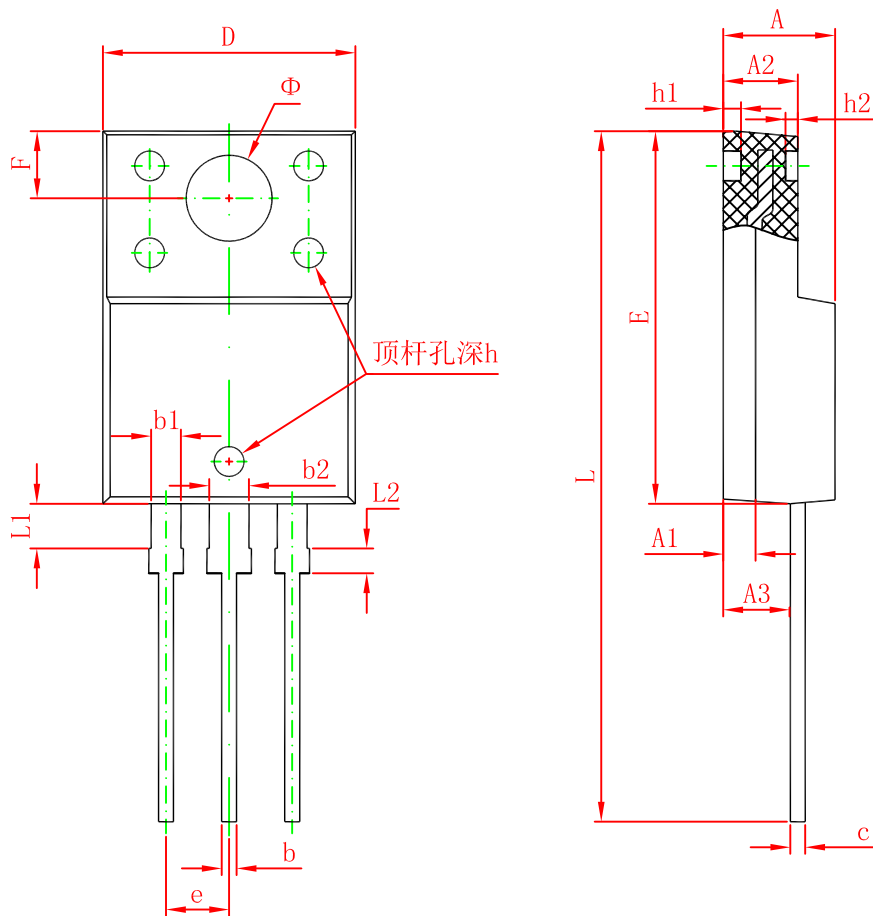

Symbol	Dimensions In Millimeters		Dimensions In Inches	
	Min.	Max.	Min.	Max.
A	4.300	4.700	0.169	0.185
A1	1.300 REF.		0.051 REF.	
A2	2.800	3.200	0.110	0.126
A3	2.500	2.900	0.098	0.114
b	0.500	0.750	0.020	0.030
b1	1.100	1.350	0.043	0.053
b2	1.500	1.750	0.059	0.069
c	0.500	0.750	0.020	0.030
D	9.960	10.360	0.392	0.408
E	14.800	15.200	0.583	0.598
e	2.540 TYP.		0.100 TYP.	
F	2.700 REF.		0.106 REF.	
Φ	3.500 REF.		0.138 REF.	
h	0.000	0.300	0.000	0.012
h1	0.800 REF.		0.031 REF.	
h2	0.500 REF.		0.020 REF.	
L	28.000	28.400	1.102	1.118
L1	1.700	1.900	0.067	0.075
L2	0.900	1.100	0.035	0.043