

TPS8268x 1600mA 高效 MicroSiP™ 降压转换器模块 (厚度 < 1.0mm)

1 特性

- 2.5V 至 5.5V 的宽 V_{IN} 范围
- 总体解决方案尺寸 < 6.7mm²
- 厚度小于 1mm 的解决方案
- DC 电压精度为 $\pm 1.5\%$
- 负载电流高达 1600mA
- 效率高达 88%
- 固定输出电压：
 - TPS8268150: 1.50V
 - TPS8268105: 1.05V
 - TPS8268090: 0.9V
- 扩展频谱, PWM 频率抖动可降低电磁干扰 (EMI)
- 同类产品中最佳的负载和线路瞬态响应
- 内部软启动
- 电流过载和热关断保护

2 应用

- 光模块
- 手机、智能电话
- 固态硬盘驱动应用
- 要求高效和极小解决方案尺寸的空间受限应用

3 说明

TPS8268x 器件是一款针对小型解决方案尺寸优化的完整 DC/DC 降压电源。封装中包含开关稳压器、电感器和输入/输出电容器。集成所有无源元件后仍属于微型尺寸解决方案, 仅为 6.7mm²。

典型应用

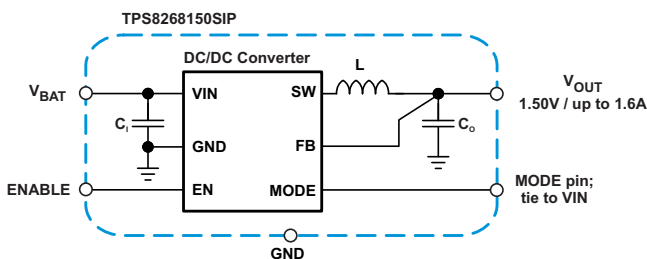

TPS8268x 基于高频同步降压 dc-dc 转换器, 它针对电池供电便携式应用进行了优化, 此类应用要求极小的解决方案尺寸和厚度。TPS8268x 针对高频和低输出电压纹波进行了优化, 支持高达 1600mA 的负载电流。该器件输入电压范围为 2.5V 到 5.5V, 支持由锂离子电池及 5V 和 3.3V 电源供电的应用。

TPS8268x 开关频率为 5.5MHz, 具有扩展频谱的功能。对于噪声敏感应用, 此特性可降低稳压输出的噪声, 并降低输入噪声。此器件支持固定输出电压, 无需外部反馈网络。

凭借这些特性以及高 PSRR 和 AC 负载调节性能, 此器件可以替代线性稳压器在相同尺寸条件下获得更高的功率转换效率。

TPS8268x 采用紧凑的 (2.3mm x 2.9mm) 薄型 BGA 封装, 适合通过标准表面贴装设备自动组装。

器件信息(1)

器件型号	封装	封装尺寸 (标称值)
TPS8268150	μ SIP	2.30mm x 2.90mm
TPS8268105	μ SIP	2.30mm x 2.90mm
TPS8268090	μ SIP	2.30mm x 2.90mm

(1) 如需了解所有可用封装, 请见数据表末尾的可订购产品附录。

TPS8268150 的效率与负载电流间的关系

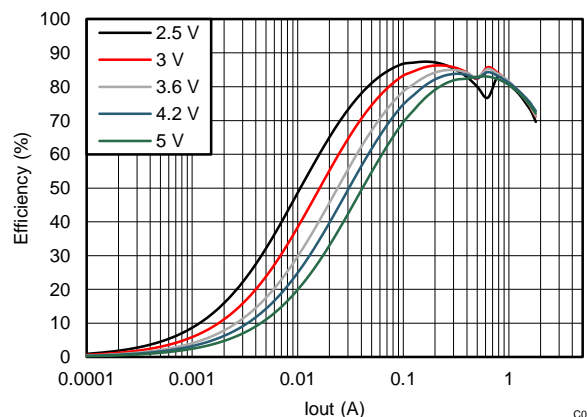

C001

目录

1	特性	1	9.4	Device Functional Modes	10
2	应用	1	10	Application and Implementation	12
3	说明	1	10.1	Application Information	12
4	修订历史记录	2	10.2	Typical Application	12
5	Device Comparison Table	3	11	Power Supply Recommendations	15
6	Pin Configuration and Functions	3	12	Layout	16
7	Specifications	4	12.1	Layout Guidelines	16
7.1	Absolute Maximum Ratings	4	12.2	Layout Example	17
7.2	Handling Ratings	4	12.3	Surface Mount Information	17
7.3	Recommended Operating Conditions	4	12.4	Thermal and Reliability Information	18
7.4	Thermal Information	5	13	器件和文档支持	20
7.5	Electrical Characteristics	5	13.1	文档支持	20
7.6	Typical Characteristics	6	13.2	相关链接	20
8	Parameter Measurement Information	8	13.3	商标	20
8.1	Schematic	8	13.4	静电放电警告	20
9	Detailed Description	9	13.5	术语表	20
9.1	Overview	9	14	机械封装和可订购信息	21
9.2	Functional Block Diagram	9	14.1	封装概要	21
9.3	Feature Description	9	14.2	MicroSiP™ DC/DC 模块封装尺寸	21

4 修订历史记录

Changes from Original (October 2014) to Revision A

Page

• 已更改 产品预览至生产数据	1
-----------------------	----------

5 Device Comparison Table ⁽¹⁾

DEVICE NUMBER	FEATURES	OUTPUT VOLTAGE	Marking
TPS8268150	PWM Spread Spectrum Modulation Output Capacitor Discharge	1.50V	YR
TPS8268105	PWM Spread Spectrum Modulation Output Capacitor Discharge	1.05V	YO
TPS8268090	PWM Spread Spectrum Modulation Output Capacitor Discharge	0.9V	YP

(1) For other voltage options please contact a TI sales representative.

6 Pin Configuration and Functions

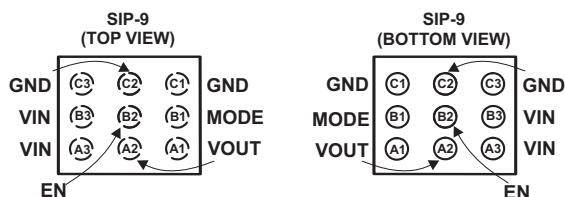

Pin Functions

PIN		I/O	DESCRIPTION
NAME	NO.		
VOUT	A1, A2	O	Power output pin. Apply output load between this pin and GND.
VIN	A3, B3	I	Supply voltage connection
EN	B2	I	This is the enable pin of the device. Connecting this pin low forces the device into shutdown mode. Pulling this pin high enables the device. This pin must not be left floating and must be terminated.
MODE	B1	I	This pin must be tied to the input supply voltage VIN.
GND	C1, C2, C3	–	Ground pin.

7 Specifications

7.1 Absolute Maximum Ratings

 over operating free-air temperature range (unless otherwise noted) ⁽¹⁾

		MIN	MAX	UNIT
V _I	Voltage at VIN ⁽²⁾	-0.3	6	V
	Voltage at VOUT ⁽²⁾	-0.3	3.6	
	Voltage at EN, MODE ⁽²⁾	-0.3	V _{IN} + 0.3	
	Peak output current		1600	mA
T _J	Operating internal junction temperature range	-40	125	°C

- (1) Stresses beyond those listed under *Absolute Maximum Ratings* may cause permanent damage to the device. These are stress ratings only, which do not imply functional operation of the device at these or any other conditions beyond those indicated under *Recommended Operating Conditions*. Exposure to absolute-maximum-rated conditions for extended periods may affect device reliability.
- (2) All voltage values are with respect to network ground terminal.

7.2 Handling Ratings

		MIN	MAX	UNIT
T _{stg}	Storage temperature range	-55	125	°C
ESD rating ⁽¹⁾ ⁽²⁾ ⁽³⁾	Human body model	-2	2	kV
	Charge device model	-500	500	V
	Machine model	-100	100	V

- (1) Electrostatic discharge (ESD) to measure device sensitivity and immunity to damage caused by assembly line electrostatic discharges in to the device.
- (2) Level listed above is the passing level per ANSI, ESDA, and JEDEC JS-001. JEDEC document JEP155 states that 500-V HBM allows safe manufacturing with a standard ESD control process.
- (3) Level listed above is the passing level per EIA-JEDEC JESD22-C101. JEDEC document JEP157 states that 250-V CDM allows safe manufacturing with a standard ESD control process.

7.3 Recommended Operating Conditions

over operating free-air temperature range (unless otherwise noted)

		MIN	NOM	MAX	UNIT
V _{IN}	Input voltage range	2.5		5.5	V
I _{OUT}	Peak output current for TPS8268090, TPS8268105	0		1600 ⁽¹⁾	mA
	Peak output current for TPS8268150				
I _{OUT}	Average output current for TPS8268090, TPS8268105	0		1200 ⁽¹⁾	mA
	Average output current for TPS8268150				
I _{OUT}	Average output current during soft-start	0		1000 ⁽¹⁾	mA
	Additional effective input capacitance	0			μF
	Additional effective output capacitance	0		30 ⁽²⁾	μF
T _A	Operating ambient temperature range	-40		85	°C

- (1) See [Thermal and Reliability Information](#) for additional details
- (2) Due to the dc bias effect of ceramic capacitors, the effective capacitance is lower than the nominal value when a voltage is applied.

7.4 Thermal Information

THERMAL METRIC ⁽¹⁾		TPS8268x	UNIT
		SIP	
		9 PINS	
R _{θJA}	Junction-to-ambient thermal resistance	62	°C/W
R _{θJC(top)}	Junction-to-case (top) thermal resistance	22	
R _{θJB}	Junction-to-board thermal resistance	25	
ψ _{JT}	Junction-to-top characterization parameter	11	
ψ _{JB}	Junction-to-board characterization parameter	25	
R _{θJC(bot)}	Junction-to-case (bottom) thermal resistance	n/a	

(1) For more information about traditional and new thermal metrics, see the *IC Package Thermal Metrics* application report, [SPRA953](#).

7.5 Electrical Characteristics

Minimum and maximum values are at VIN = 2.5V to 5.5V, EN = VIN and T_A = -40°C to 85°C; Circuit of Parameter Measurement Information section (unless otherwise noted). Typical values are at VIN = 3.6V, EN = VIN and T_A = 25°C (unless otherwise noted).

PARAMETER	TEST CONDITIONS		MIN	TYP	MAX	UNIT	
SUPPLY CURRENT							
I _Q	Operating quiescent current	I _{OUT} = 0mA		7		mA	
I _{SD}	Shutdown current	EN = low		0.5	5	μA	
UVLO	Undervoltage lockout threshold	VIN rising		2.1	2.3	V	
		VIN falling		1.95	2.25	V	
ENABLE, MODE							
V _{IH}	High-level input voltage		0.9			V	
V _{IL}	Low-level input voltage				0.4	V	
I _{ikg}	Input leakage current	Input connected to GND or VIN; T _J = -40°C to 85°C		0.01	1.5	μA	
PROTECTION							
	Thermal shutdown	Temperature rising		140		°C	
	Thermal shutdown hysteresis	Temperature falling		10		°C	
I _{LIM}	Average output current limit			2100		mA	
I _{SC}	Input current limit under short-circuit condition	V _{OUT} shorted to ground		150		mA	
OUTPUT							
V _{OUT,NOM}	Nominal output voltage	TPS8268150		1.50		V	
		TPS8268105		1.05		V	
		TPS8268090		0.9		V	
	Output voltage accuracy	TPS8268105, TPS8268090	2.8V ≤ VIN ≤ 5.5V, 0mA ≤ I _{OUT} ≤ 1600 mA T _J = -40°C to 85°C	0.985×V _{OUT,NOM}	V _{OUT,NOM}	1.015×V _{OUT,NOM}	V
		TPS8268150	3.2V ≤ VIN ≤ 5.5V, 0mA ≤ I _{OUT} ≤ 1600 mA T _J = -40°C to 85°C				
		TPS8268105, TPS8268090	2.7V ≤ VIN ≤ 5.5V, 0mA ≤ I _{OUT} ≤ 1200 mA T _J = -40°C to 125°C	0.98×V _{OUT,NOM}	V _{OUT,NOM}	1.025×V _{OUT,NOM}	V
		TPS8268150	2.9V ≤ VIN ≤ 5.5V, 0mA ≤ I _{OUT} ≤ 1200 mA T _J = -40°C to 125°C				
	Line regulation	VIN = 2.5V to 5.5V, I _{OUT} = 200 mA		0.2		%/V	
	Load regulation	I _{OUT} = 0mA to 1600 mA		-0.85		%/A	
f _{SW}	Nominal oscillator frequency	I _{OUT} = 0mA		5.5		MHz	
	Start-up delay time	Time from EN = high to start switching		120	300	μs	
t _{RAMP}	Ramp time	I _{OUT} = 0mA, Time from start switching until 95% of nominal output voltage		150		μs	
R _{DIS}	VOUT discharge resistor			12		Ω	

7.6 Typical Characteristics

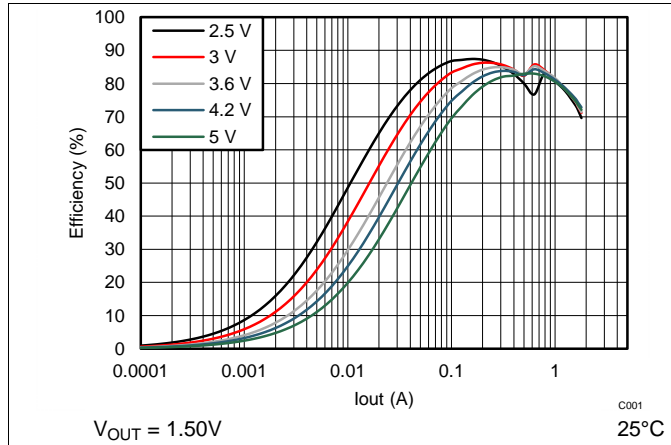

Figure 1. Efficiency vs Output Current

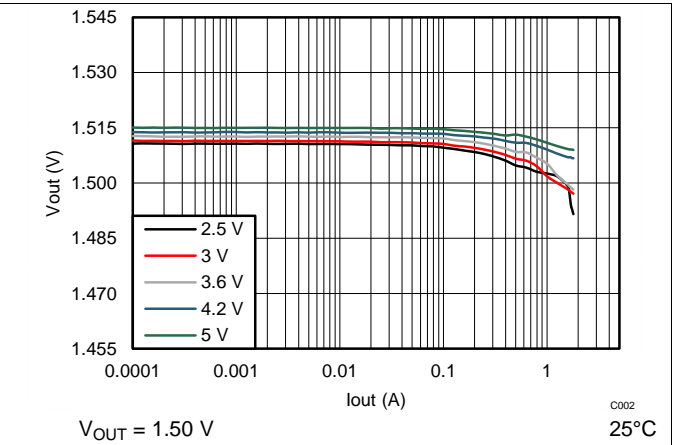

Figure 2. Output Voltage vs Output Current

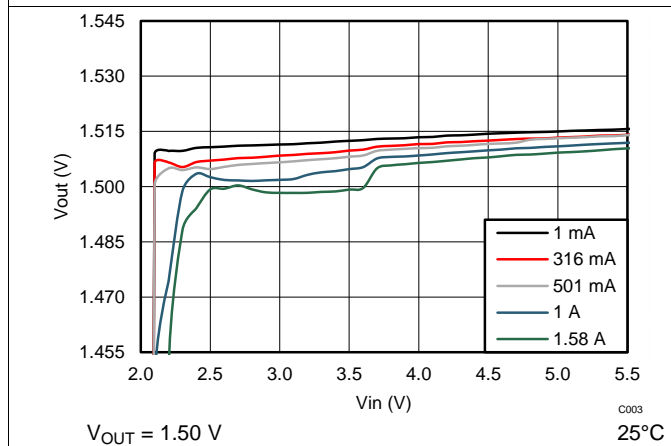

Figure 3. Output Voltage vs Input Voltage

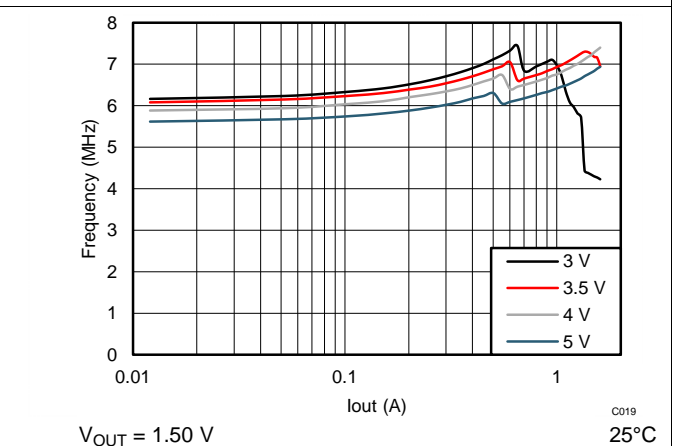

Figure 4. Switching Frequency vs Output Current

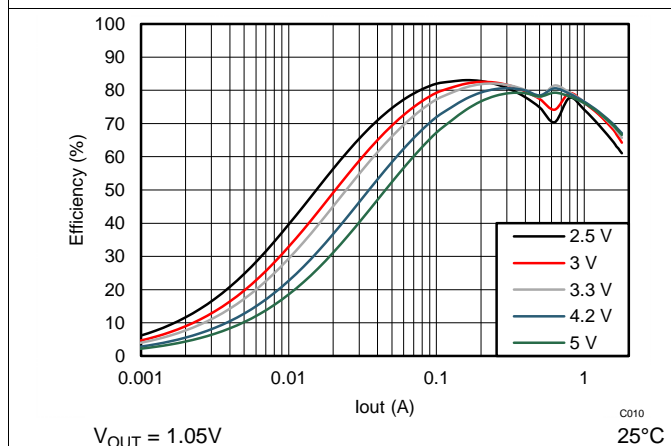

Figure 5. Efficiency vs Output Current

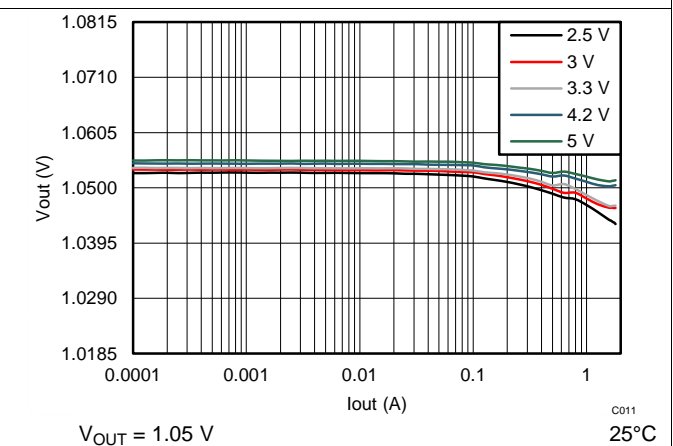

Figure 6. Output Voltage vs Output Current

Typical Characteristics (continued)

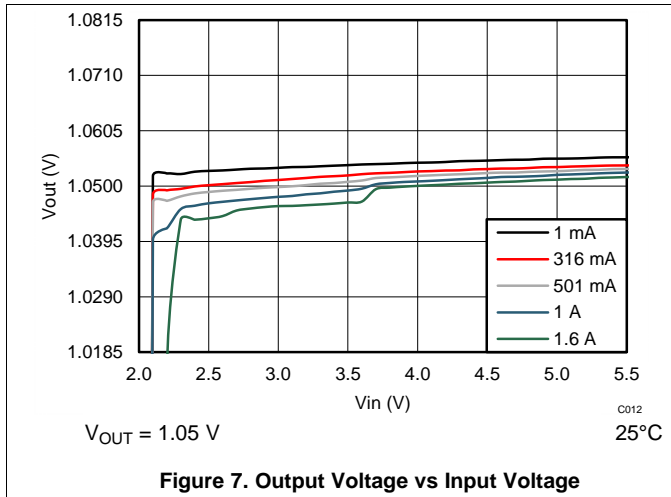

Figure 7. Output Voltage vs Input Voltage

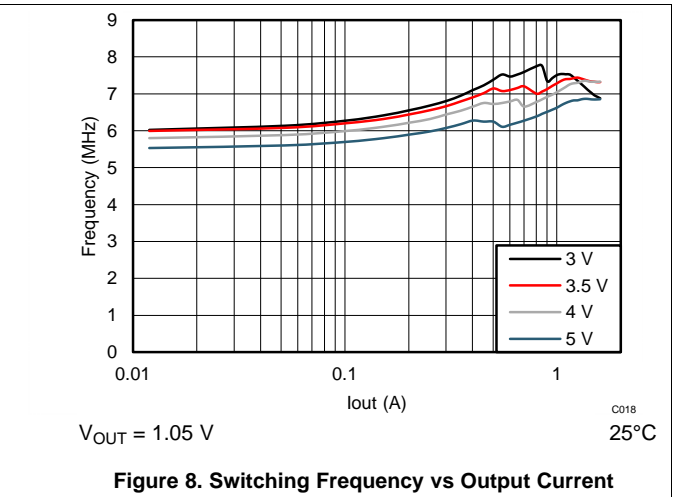

Figure 8. Switching Frequency vs Output Current

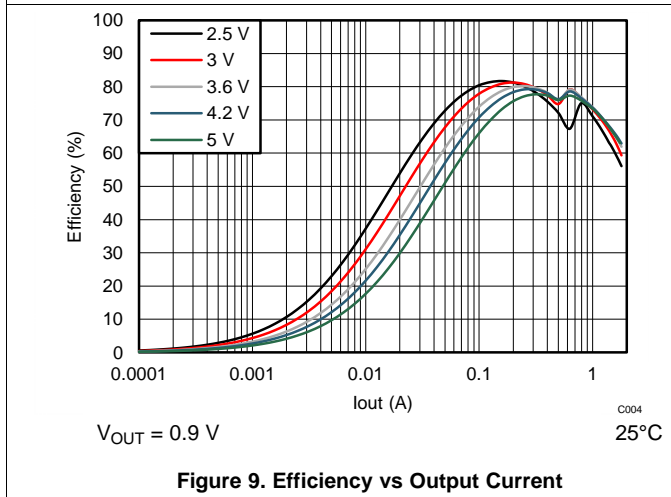

Figure 9. Efficiency vs Output Current

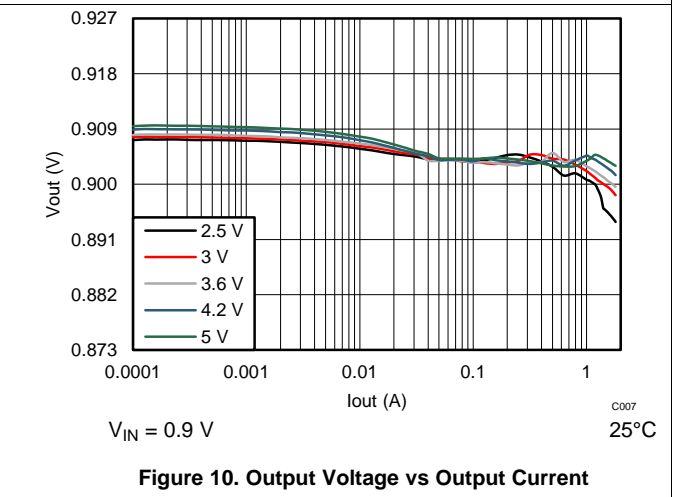

Figure 10. Output Voltage vs Output Current

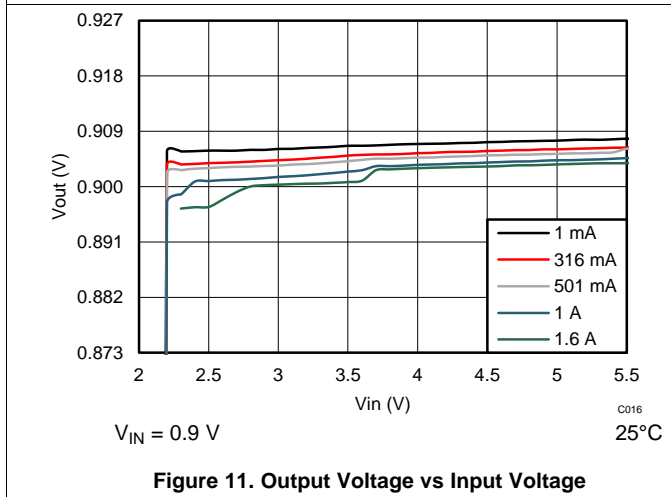

Figure 11. Output Voltage vs Input Voltage

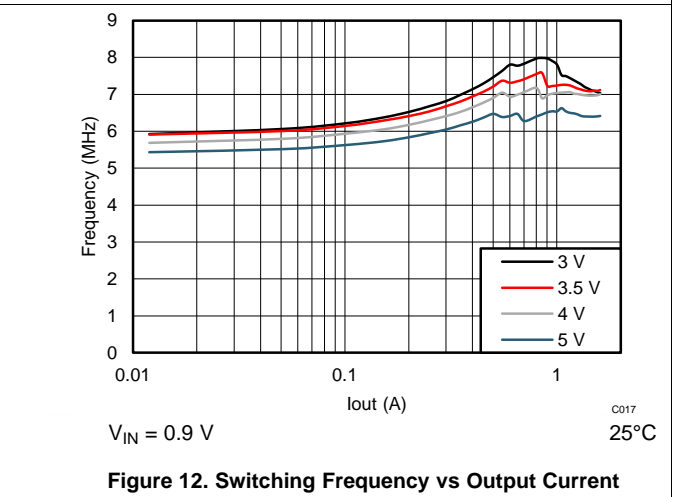
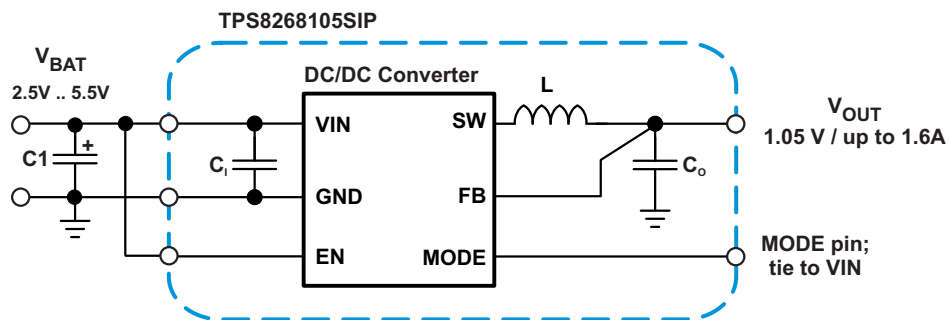

Figure 12. Switching Frequency vs Output Current

8 Parameter Measurement Information

8.1 Schematic



Reference	Description	Manufacturer
IC1	MicroSIP Module TPS8268xSIP	Texas Instruments
C1	Tantalum Capacitor; T520B157M006ATE025; 150uF/6.3V	Kemet

9 Detailed Description

9.1 Overview

The TPS8268x is a complete DC/DC step-down power supply intended for small size and low profile applications. Included in the package are the switching regulator, inductor and input/output capacitors. It is a complete Plug & Play Solution, meaning typically no additional components are required to finish the design. Integration of all required passive components enables a tiny solution size of only 6.7mm². The converter operates with fixed frequency pulse width modulation (PWM).

The TPS8268x integrates an input current limit to protect the device against heavy load or short circuits and features an undervoltage lockout circuit to prevent the device from misoperation at low input voltages.

9.2 Functional Block Diagram

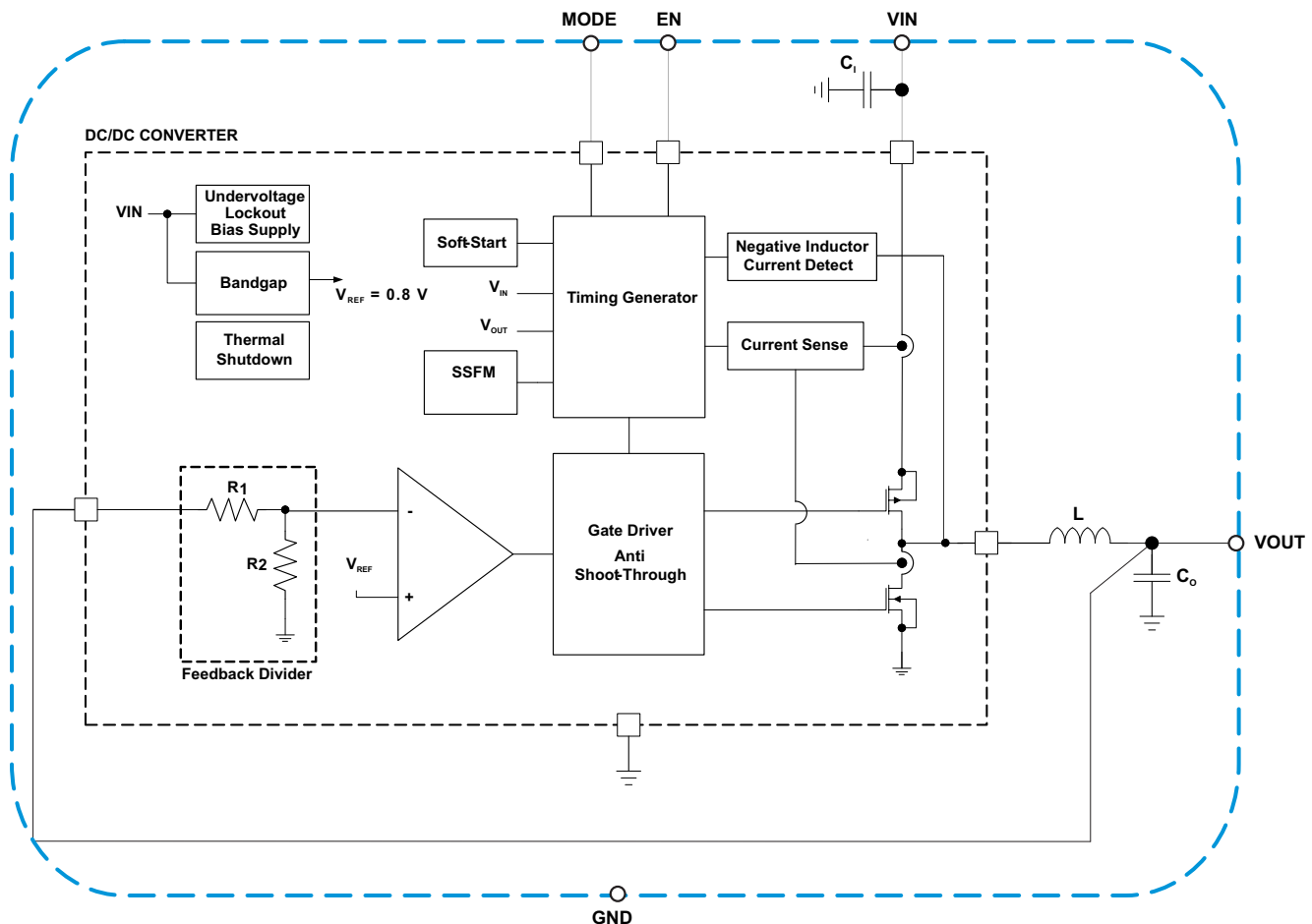

9.3 Feature Description

9.3.1 Soft Start

The TPS8268x has an internal soft start circuit that controls the ramp up of the output voltage. Once the converter is enabled and the input voltage is above the undervoltage lockout threshold V_{UVLO}, the output voltage ramps up to 95% of its nominal value within t_{Ramp} of typ. 150μs. This ensures a controlled ramp up of the output voltage and limits the input voltage drop when a battery or a high-impedance power source is connected to the input of the DC/DC converter.

The inrush current during start-up is directly related to the effective capacitance and load present at the output of the converter.

Feature Description (continued)

During soft start, the current limit is reduced to 2/3 of its nominal value. The maximum load current during soft start should be less than 1A. Once the internal reference voltage has reached 90% of its target value, the current limit is set to its nominal target value.

9.3.2 Undervoltage Lockout

The undervoltage lockout circuit prevents the device from misoperation at low input voltages. It prevents the converter from turning on either MOSFET under undefined conditions. The TPS8268x has a rising UVLO threshold of 2.1V (typical).

9.3.3 Short-Circuit Protection

The TPS8268x integrates current limit circuitry to protect the device against heavy load or short circuits. When the average current in the high-side MOSFET reaches its current limit, the high-side MOSFET is turned off and the low-side MOSFET is turned on ramping down the inductor current.

As soon as the converter detects a short circuit condition, it shuts down. After a delay of approximately 20 μ s, the converter restarts. In case the short circuit condition remains, the converter shuts down again after hitting the current limit threshold. In case the short circuit condition remains present on the converters output, the converter periodically re-starts with a small duty cycle and shuts down again, thereby limiting the current drawn from the input.

9.3.4 Thermal Shutdown

As soon as the junction temperature, T_j , exceeds typically 140°C, the device goes into thermal shutdown. In this mode, the power stage is turned off. The device continues its operation when the junction temperature falls below typically 130°C.

9.3.5 Enable

The TPS8268x device starts operation when EN is set high. For proper operation, the EN pin must be terminated and must not be left floating.

Pulling the EN pin low forces the device into shutdown, with a shutdown current of typically 0.5 μ A. In this mode, the internal high-side and low-side MOSFETs are turned off, the internal resistor feedback divider is disconnected, and the entire internal control circuitry is switched off. The TPS8268x device actively discharges the output capacitor when it turns off. The integrated discharge resistor has a typical resistance of 12 Ω . This internal discharge transistor is only turned on after the device had been enabled at least once. The required time to discharge the output capacitor at the output node depends on load current and the effective output capacitance.

The TPS8268x is designed such that it can start into a pre-biased output, in case the output discharge circuit was active for too short a time to fully discharge the output capacitor. In this case, the converter starts switching as soon as the internal reference has approximately reached the equivalent voltage to the output voltage present. It then ramps the output from that voltage level to its target value.

9.3.6 MODE Pin

This pin must be tied to the input voltage V_{IN} and must not be left floating.

9.4 Device Functional Modes

9.4.1 Spread Spectrum, PWM Frequency Dithering

The goal is to spread out the emitted RF energy over a larger frequency range, so that the resulting EMI is similar to white noise. The end result is a spectrum that is continuous and lower in peak amplitude, making it easier to comply with electromagnetic interference (EMI) standards and with power supply ripple requirements in cellular and non-cellular wireless applications. Radio receivers are typically susceptible to narrowband noise that is focused on specific frequencies.

Device Functional Modes (continued)

Switching regulators can be particularly troublesome in applications where electromagnetic interference (EMI) is a concern. Switching regulators operate on a cycle-by-cycle basis to transfer power to their output. In most cases, the frequency of operation is either fixed or regulated, based on the output load. This method of conversion creates large components of noise at the frequency of operation (fundamental) and multiples of the operating frequency (harmonics).

The spread spectrum architecture varies the switching frequency by around $\pm 10\%$ of the nominal switching frequency, thereby significantly reducing the peak radiated and conducted noise on both the input and output supplies. The frequency dithering scheme is modulated with a triangle profile and a modulation frequency f_m .

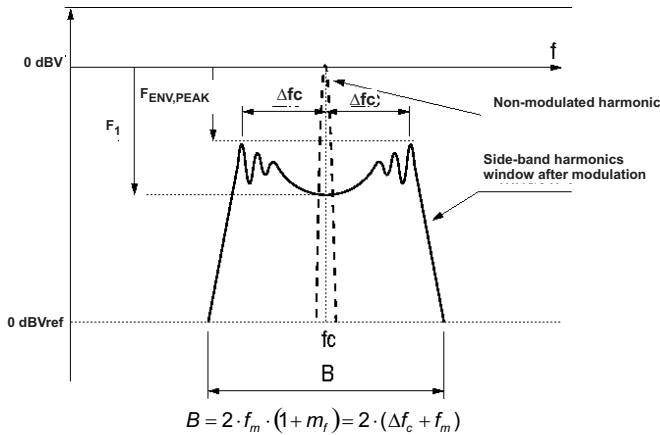

Figure 13. Spectrum Of A Frequency Modulated Sin. Wave With Sinusoidal Variation In Time

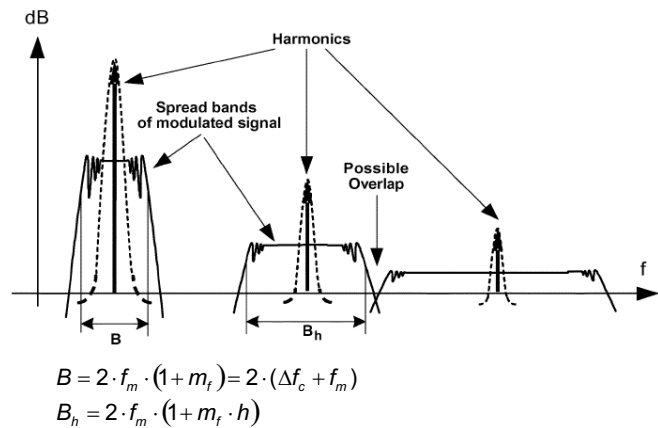

Figure 14. Spread Bands Of Harmonics In Modulated Square Signals ⁽¹⁾

The above figures show that after modulation the side-band harmonic is attenuated compared to the non-modulated harmonic, and the harmonic energy is spread into a certain frequency band. The higher the modulation index (m_f), the larger the attenuation.

$$m_f = \frac{\delta \times f_c}{f_m} \quad (1)$$

where:

f_c is the carrier frequency (5.5MHz)

f_m is the modulating frequency (approx. $0.008 \cdot f_c$)

δ is the modulation ratio (approx 0.1)

$$\delta = \frac{\Delta f_c}{f_c} \quad (2)$$

The maximum switching frequency f_c is limited by the device and finally the parameter modulation ratio (δ), together with f_m , which is the side-band harmonic's bandwidth around the carrier frequency f_c . The bandwidth of a frequency modulated waveform is approximately given by Carson's rule and is summarized as:

$$B = 2 \times f_m \times (1 + m_f) = 2 \times (\Delta f_c + f_m) \quad (3)$$

$f_m < RBW$ (resolution bandwidth): The receiver is not able to distinguish individual side-band harmonics, so, several harmonics are added in the input filter and the measured value is higher than expected in theoretical calculations.

$f_m > RBW$: The receiver is able to properly measure each individual side-band harmonic separately, so the measurements match with the theoretical calculations.

(1) Spectrum illustrations and formulae (Figure 13 and Figure 14) copyright IEEE TRANSACTIONS ON ELECTROMAGNETIC COMPATIBILITY, VOL. 47, NO.3, AUGUST 2005. See References Section for full citation.

10 Application and Implementation

NOTE

Information in the following applications sections is not part of the TI component specification, and TI does not warrant its accuracy or completeness. TI's customers are responsible for determining suitability of components for their purposes. Customers should validate and test their design implementation to confirm system functionality.

10.1 Application Information

The TPS8268x device is a complete DC/DC step-down power supply optimized for small solution size. Included in the package are the switching regulator, inductor and input/output capacitors. Integration of passive components enables a tiny solution size of only 6.7mm².

10.2 Typical Application

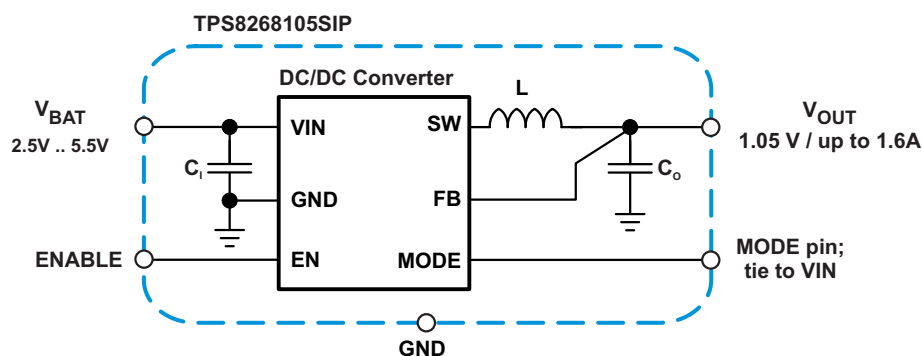

Figure 15. Typical Application Schematic

10.2.1 Design Requirements

Figure 15 shows the schematic of the typical application. The following design guidelines provide all information to operate the device within the recommended operating conditions.

10.2.2 Detailed Design Procedure

The TPS8268x allows the design of a complete power supply with no additional external components. The input capacitance can be increased in case the source impedance is large or if there are high load transients expected at the output. The dc bias effect of the input and output capacitors must be taken into account and the total capacitance on the output must not exceed the value given in the recommended operating conditions.

10.2.2.1 Input Capacitor Selection

Because the nature of the buck converter has a pulsating input current, a low ESR input capacitor is required.

For most applications, the input capacitor that is integrated into the TPS8268x is sufficient. If the application exhibits a noisy or erratic switching frequency, experiment with additional input ceramic capacitance to find a remedy.

The TPS8268x uses a tiny ceramic input capacitor. When a ceramic capacitor is combined with trace or cable inductance, such as from a wall adapter, a load step at the output can induce ringing at the VIN pin. This ringing can couple to the output and be mistaken as loop instability or can even damage the part. In this circumstance, additional "bulk" capacitance, such as electrolytic or tantalum, should be placed between the input of the converter and the power source lead to reduce ringing that can occur between the inductance of the power source leads and C₁.

Typical Application (continued)

10.2.2.2 Output Capacitor Selection

The advanced fast-response voltage mode control scheme of the TPS8268x allows the use of tiny ceramic output capacitors. Ceramic capacitors with low ESR values have the lowest output voltage ripple and are recommended. For most applications, the output capacitor integrated in the TPS8268x is sufficient. An additional output capacitor may be used for the purpose of improving AC voltage accuracy during large load transients.

To further reduce the voltage drop during load transients, additional external output capacitance up to 30 μ F can be added. A low ESR multilayer ceramic capacitor (MLCC) is suitable for most applications. The total effective output capacitance must remain below 30 μ F.

As the device operates in PWM mode, the overall output voltage ripple is the sum of the voltage step that is caused by the output capacitor's ESL and the ripple current that flows through the output capacitor's impedance.

Because the damping factor in the output path is directly related to several resistive parameters (e.g. inductor DCR, power-stage $r_{DS(on)}$, PCB DC resistance, load switches $r_{DS(on)}$...) that are temperature dependant, the converter's small and large signal behavior should be checked over the input voltage range, load current range and temperature range.

The easiest test is to evaluate, directly at the converter's output, the following items:

- efficiency
- load transient response
- output voltage ripple

During the recovery time from a load transient, the output voltage can be monitored for settling time, overshoot or ringing that helps judge the converter's stability. Without any ringing, the loop typically has more than 45° of phase margin.

10.2.3 Application Curves

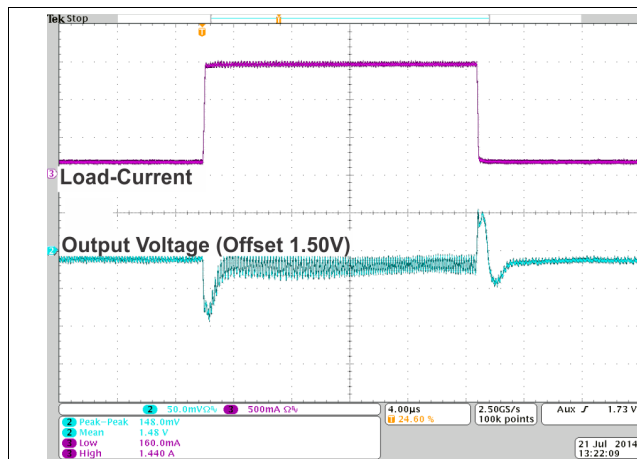

Figure 16. Load Transient Response for TPS8268150
(Vout = 1.5V, Iout = 160mA to 1.44A to 160mA, Vin = 5V)

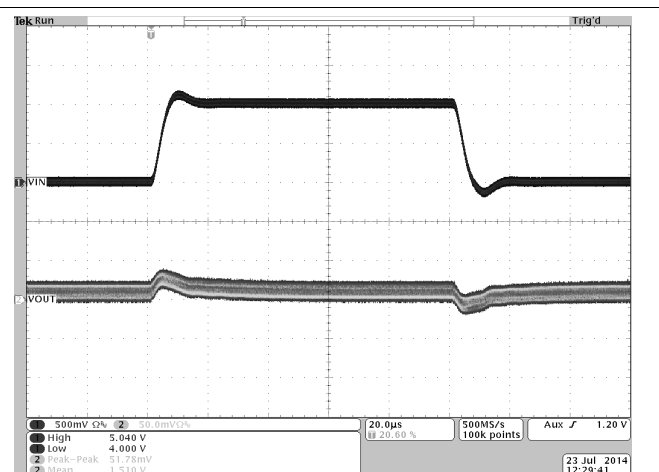

Figure 17. Line Transient Response for TPS8268150
(Vout = 1.5V, Iout = 800mA, Vin = 4V to 5V to 4V)

Typical Application (continued)

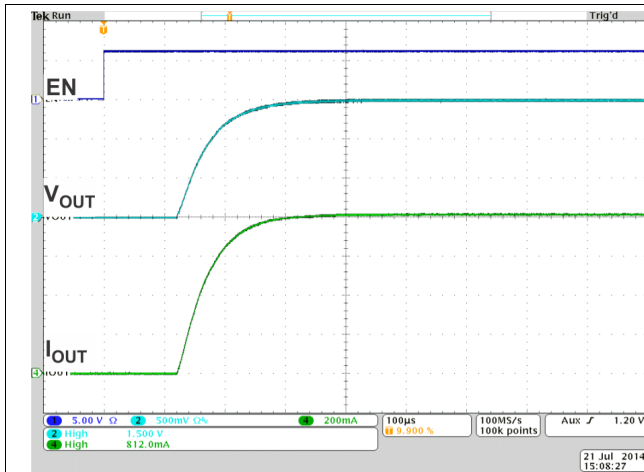

Figure 18. Startup for TPS8268150
(Vin = 5V, Vout = 1.5V)

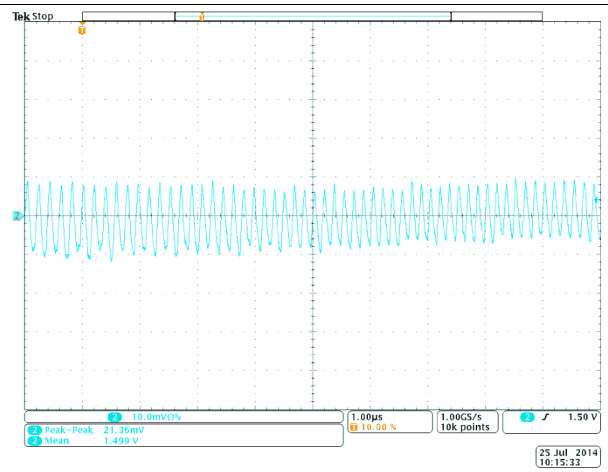

Figure 19. Output Voltage Ripple for TPS8268150
(Vin = 5V, Vout = 1.5V, Iout = 900mA)

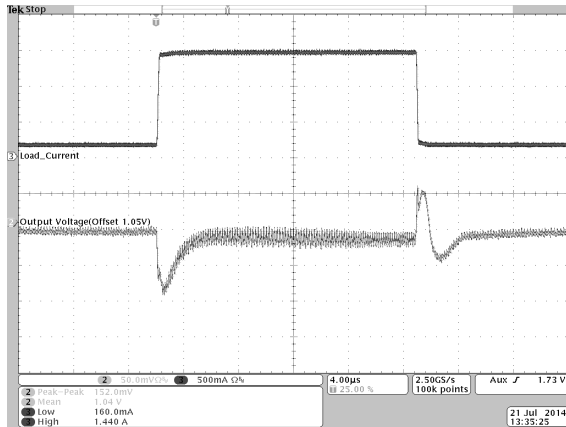

Figure 20. Load Transient Response for TPS8268105
(Vout = 1.05V, Iout = 160mA to 1.44A to 160mA, Vin = 5V)

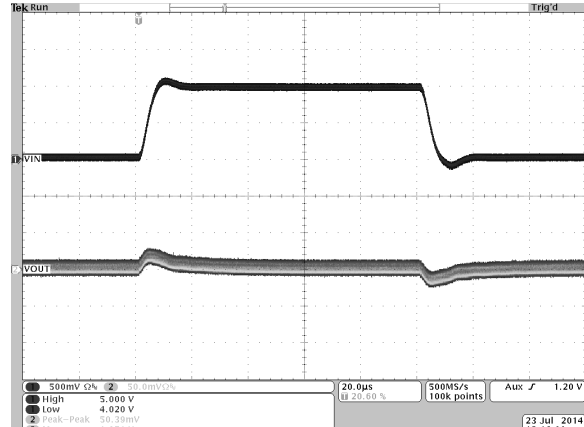

Figure 21. Line Transient Response for TPS8268105
(Vout = 1.05V; Iout = 900mA, Vin = 4V to 5V to 4V)

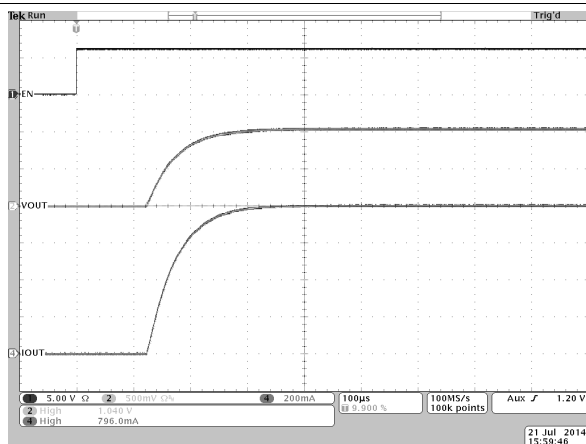

Figure 22. Startup for TPS8268105
(Vin = 5V, Vout = 1.05V)

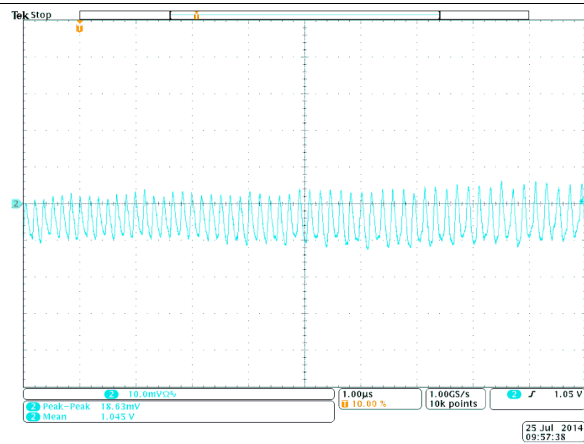

Figure 23. Output Voltage Ripple for TPS8268105
(Vin = 5V, Vout = 1.05V, Iout = 900mA)

Typical Application (continued)

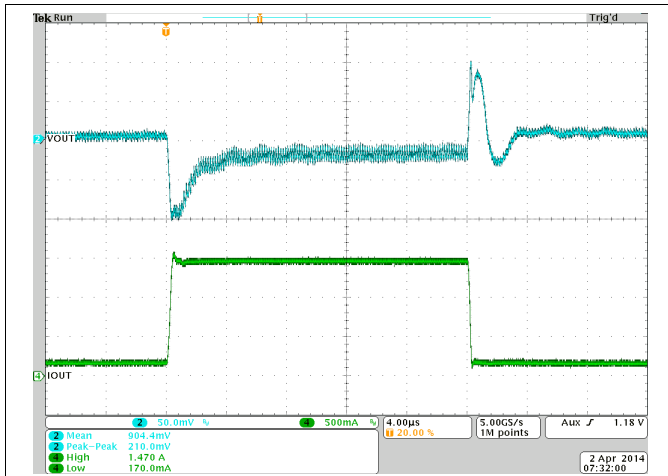

Figure 24. Load Transient Response for TPS8268090 (Vout = 0.9V, Iout = 170mA to 1.47A to 170mA, Vin = 5V)

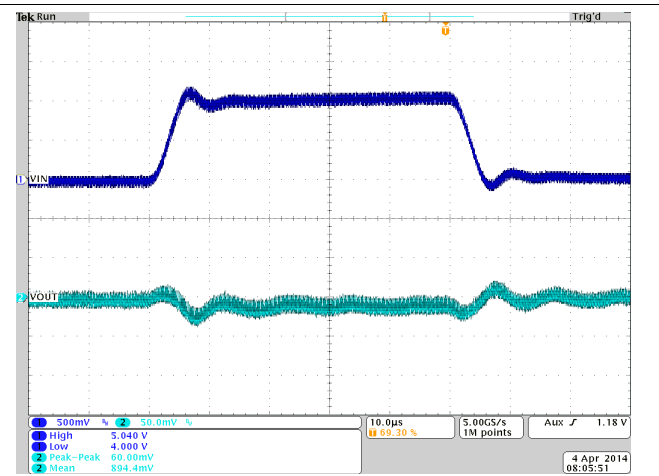

Figure 25. Line Transient Response for TPS8268090 (Vout = 0.9V; Iout = 900mA, Vin = 4V to 5V to 4V)

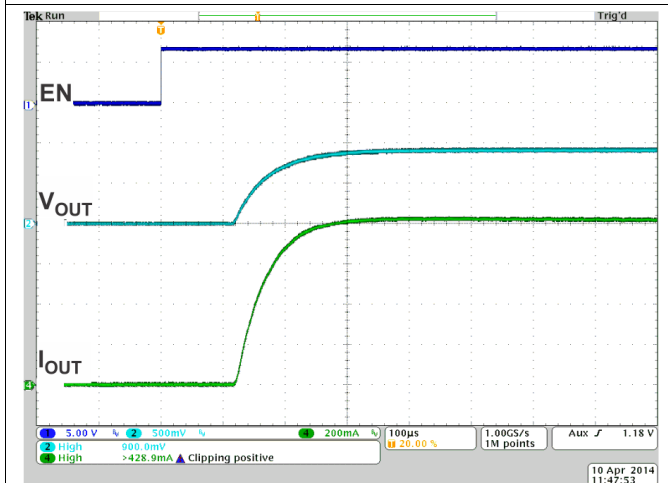

Figure 26. Startup for TPS8268090 (Vin = 5V, Vout = 0.9V)

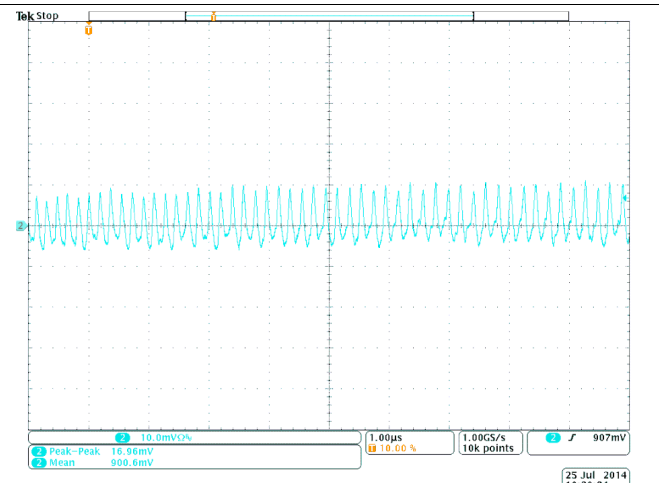

Figure 27. Output Voltage Ripple for TPS8268090 (Vin = 5V, Vout = 0.9V, Iout = 900mA)

11 Power Supply Recommendations

The TPS8268x has no special requirements for its input power supply. The input power supply to the TPS8268x must have a current rating according to the supply voltage and output current of the TPS8268x.

12 Layout

12.1 Layout Guidelines

TPS8268x allows the design of a power supply with small solution size. In order to properly dissipate the heat, wide copper traces for the power connections should be used to distribute the heat across the PCB. If possible, a GND plane should be used as it provides a low impedance connection as well as serves as a heat sink.

In making the pad size for the SiP LGA balls, it is recommended that the layout use a non-solder-mask defined (NSMD) land. With this method, the solder mask opening is made larger than the desired land area, and the opening size is defined by the copper pad width. Figure 28 shows the appropriate diameters for a MicroSiP™ layout.

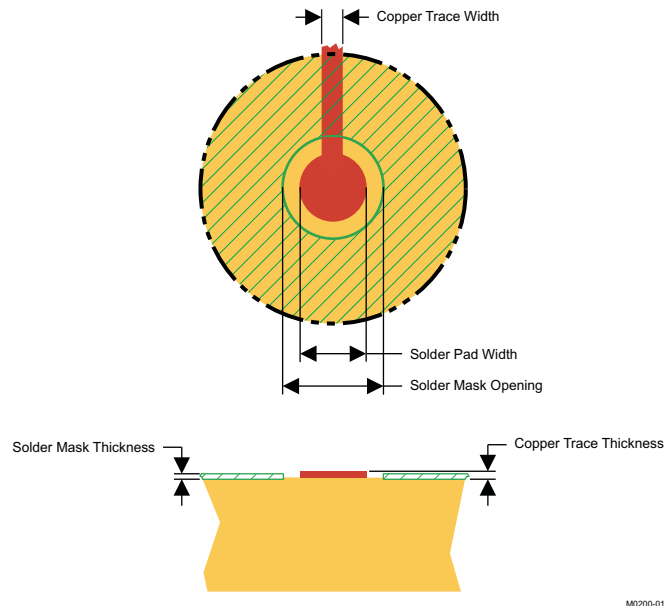

Figure 28. Recommended Land Pattern Image and Dimensions

SOLDER PAD DEFINITIONS ⁽¹⁾⁽²⁾⁽³⁾⁽⁴⁾	COPPER PAD	SOLDER MASK ⁽⁵⁾ OPENING	COPPER THICKNESS	STENCIL ⁽⁶⁾ OPENING	STENCIL THICKNESS
Non-solder-mask defined (NSMD)	0.30mm	0.360mm	1oz max (0.032mm)	0.34mm diameter	0.1mm thick

- (1) Circuit traces from non-solder-mask defined PCB lands should be 75µm to 100µm wide in the exposed area inside the solder mask opening. Wider trace widths reduce device stand off and slightly reduce reliability. However, wider traces may be used to improve the thermal relief of the device as well as to provide sufficient current handling.
- (2) Best reliability results are achieved when the PCB laminate glass transition temperature is above the operating range of the intended application.
- (3) Recommend solder paste is Type 3 or Type 4.
- (4) For a PCB using a Ni/Au surface finish, the gold thickness should be less than 0.5µm to avoid a reduction in thermal fatigue performance.
- (5) Solder mask thickness should be less than 20 µm on top of the copper circuit pattern.
- (6) For best solder stencil performance use laser cut stencils with electro polishing. Chemically etched stencils give inferior solder paste volume control.

12.2 Layout Example

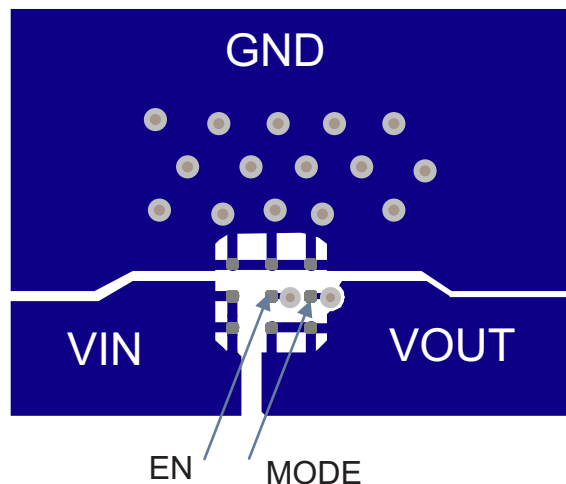

Figure 29. Recommended PCB Layout

12.3 Surface Mount Information

The TPS8268x MicroSiP™ DC/DC converter uses an open frame construction that is designed for a fully automated assembly process and that features a large surface area for pick and place operations. See the "Pick Area" in the package drawings.

Package height and weight have been kept to a minimum to allow the MicroSiP™ device to be handled similarly to a 0805 component.

See JEDEC/IPC standard J-STD-20b for reflow recommendations.

12.4 Thermal and Reliability Information

The TPS8268x's output current may need to be de-rated if it is required to operate in a high ambient temperature or deliver a large amount of continuous power. The amount of current de-rating is dependent upon the input voltage, output power and environmental thermal conditions. Care should especially be taken in applications where the localized PCB temperature exceeds 65°C.

The TPS8268x die and inductor temperature should be kept lower than the maximum rating of 125°C, so care should be taken in the circuit layout to ensure good heat sinking. Sufficient cooling should be provided to ensure reliable operation.

Three basic approaches for enhancing thermal performance are listed below:

- Improve the power dissipation capability of the PCB design.
- Improve the thermal coupling of the component to the PCB.
- Introduce airflow into the system.

To estimate the junction temperature, approximate the power dissipation within the TPS8268x by applying the typical efficiency stated in this datasheet to the desired output power; or, by taking an actual power measurement. Then, calculate the internal temperature rise of the TPS8268x above the surface of the printed circuit board by multiplying the TPS8268x's power dissipation by its thermal resistance.

The thermal resistance numbers listed in the Thermal Information table are based on modeling the MicroSiP™ package mounted on a high-K test board specified per the JEDEC standard. For increased accuracy and fidelity to the actual application, it is recommended to run a thermal image analysis of the actual system.

Thermal measurements have been taken on the EVM to give a guideline on what temperature can be expected when the device is operated in free air at 25°C ambient under a certain load. The temperatures have been checked at 4 different spots as listed below:

- Spot1: temperature of the input capacitor
- Spot2: temperature of the output capacitor
- Spot3: temperature of the inductor
- Spot4: temperature on the main pcb next to the module

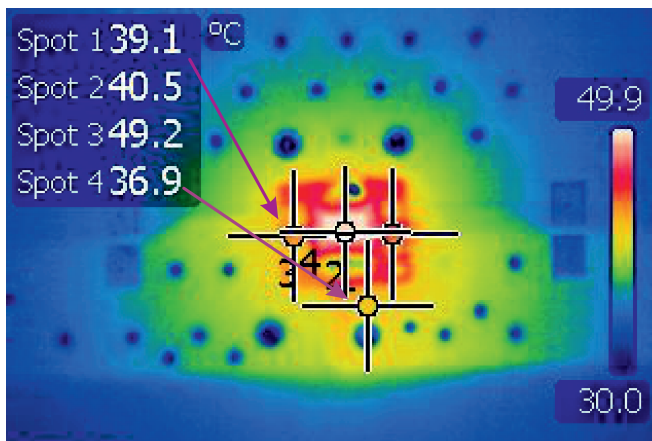

**Figure 30. $V_{IN}= 5V$, $V_{OUT}=1.05V$, $I_{OUT}= 1A$
388mW Power Dissipation**

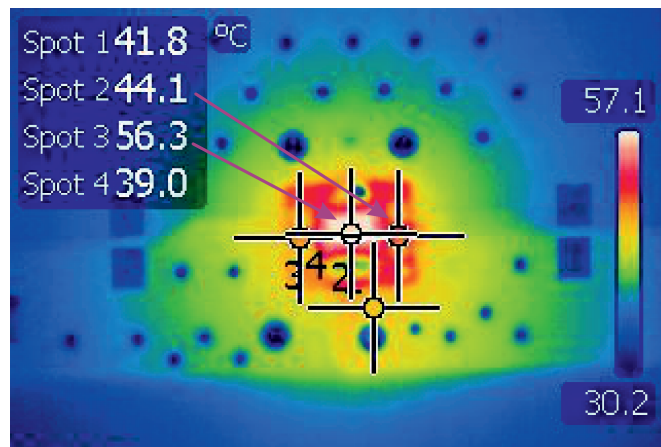

**Figure 31. $V_{IN}= 5V$, $V_{OUT}= 1.05V$, $I_{OUT}= 1.2A$
466mW Power Dissipation**

The TPS8268x contains a thermal shutdown that inhibits switching at high junction temperatures. The activation threshold of this function, however, is above 125°C to avoid interfering with normal operation. Thus, prolonged or repetitive operation under a condition in which the thermal shutdown activates necessarily means that the components internal to the MicroSiP™ package are subjected to high temperatures for prolonged or repetitive intervals, which may decrease the reliability of the device.

Thermal and Reliability Information (continued)

MLCC capacitor reliability/lifetime depends on temperature and applied voltage. At higher temperatures, MLCC capacitors are subject to stronger stress. On the basis of frequently evaluated failure rates determined with standardized test conditions, the reliability of all MLCC capacitors can be calculated for their actual operating temperature and voltage.

Failures caused by systematic degradation are described by the Arrhenius model. The most critical parameter (IR) is the Insulation Resistance (i.e. leakage current). The drop of IR below a lower limit (e.g. 1 MΩ) is used as the failure criterion. See [Figure 32](#) and [Figure 33](#). Note that the wear-out mechanisms occurring in the MLCC capacitors are not reversible but cumulative over time.

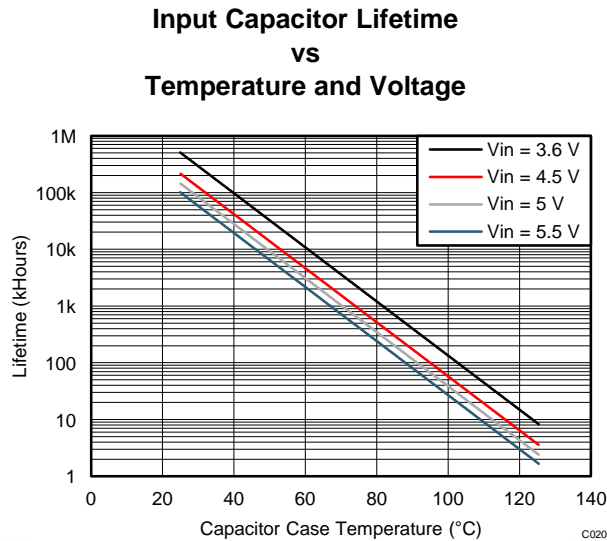

Figure 32. Input Capacitor Lifetime

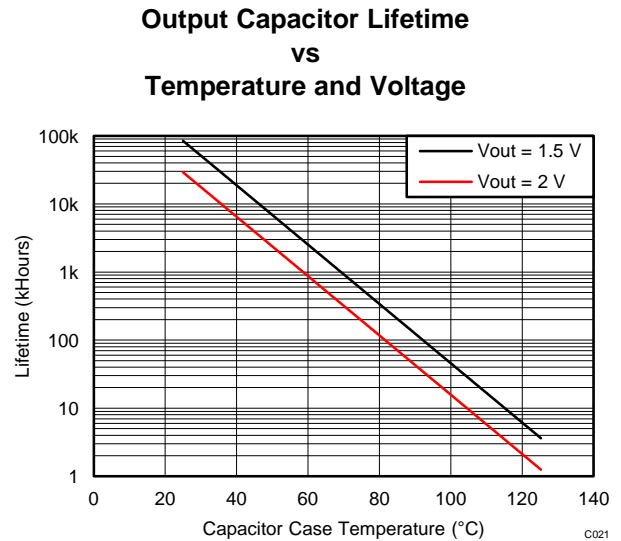

Figure 33. Output Capacitor Lifetime

13 器件和文档支持

13.1 文档支持

13.1.1 参考书目

“使用频率调制技术的开关电源转换器中的电磁干扰 (EMI) 减少”，《电气与电子工程师协会 (IEEE) 电磁兼容性汇刊》，卷4, NO.3, 2005 年 8 月, 第 569-576 页 作者 Josep Balcells, Alfonso Santolaria, Antonio Orlandi, David González, Javier Gago。

13.2 相关链接

以下表格列出了快速访问链接。范围包括技术文档、支持与社区资源、工具和软件，并且可以快速访问样片或购买链接。

表 1. 相关链接

器件	产品文件夹	样片与购买	技术文档	工具与软件	支持与社区
TPS8268150	请单击此处	请单击此处	请单击此处	请单击此处	请单击此处
TPS8268105	请单击此处	请单击此处	请单击此处	请单击此处	请单击此处
TPS8268090	请单击此处	请单击此处	请单击此处	请单击此处	请单击此处

13.3 商标

MicroSiP is a trademark of Texas Instruments.

13.4 静电放电警告



这些装置包含有限的内置 ESD 保护。存储或装卸时，应将导线一起截短或将装置放置于导电泡棉中，以防止 MOS 门极遭受静电损伤。

13.5 术语表

SLYZ022 — TI 术语表。

这份术语表列出并解释术语、首字母缩略词和定义。

14 机械封装和可订购信息

以下页中包括机械封装和可订购信息。 这些信息是针对指定器件可提供的最新数据。 这些数据会在无通知且不对本文档进行修订的情况下发生改变。 欲获得该数据表的浏览器版本，请查阅左侧的导航栏。

14.1 封装概要

SIP 封装

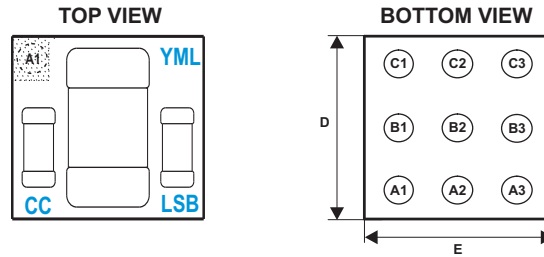

代码：

- CC - 客户代码（特定器件/电压）
- YML—Y：年，M：月，L：批次跟踪码
- LSB—L：批次跟踪码，S：地点代码，B：主板定位器

14.2 MicroSiP™ DC/DC 模块封装尺寸

TPS8268x 采用 9 凸点球状引脚栅格阵列 (BGA) 封装。封装尺寸为：

- $D = 2.30 \pm 0.05\text{mm}$
- $E = 2.90 \pm 0.05\text{mm}$

重要声明

德州仪器(TI)及其下属子公司有权根据 JESD46 最新标准,对所提供的产品和服务进行更正、修改、增强、改进或其它更改,并有权根据 JESD48 最新标准中止提供任何产品和服务。客户在下订单前应获取最新的相关信息,并验证这些信息是否完整且是最新的。所有产品的销售都遵循在订单确认时所提供的TI 销售条款与条件。

TI 保证其所销售的组件的性能符合产品销售时 TI 半导体产品销售条件与条款的适用规范。仅在 TI 保证的范围内,且 TI 认为有必要时才会使用测试或其它质量控制技术。除非适用法律做出了硬性规定,否则没有必要对每种组件的所有参数进行测试。

TI 对应用帮助或客户产品设计不承担任何义务。客户应对其使用 TI 组件的产品和应用自行负责。为尽量减小与客户产品和应用相关的风险,客户应提供充分的设计与操作安全措施。

TI 不对任何 TI 专利权、版权、屏蔽作品权或其它与使用了 TI 组件或服务的组合设备、机器或流程相关的 TI 知识产权中授予的直接或隐含权限作出任何保证或解释。TI 所发布的与第三方产品或服务有关的信息,不能构成从 TI 获得使用这些产品或服务的许可、授权、或认可。使用此类信息可能需要获得第三方的专利权或其它知识产权方面的许可,或是 TI 的专利权或其它知识产权方面的许可。

对于 TI 的产品手册或数据表中 TI 信息的重要部分,仅在没有对内容进行任何篡改且带有相关授权、条件、限制和声明的情况下才允许进行复制。TI 对此类篡改过的文件不承担任何责任或义务。复制第三方的信息可能需要服从额外的限制条件。

在转售 TI 组件或服务时,如果对该组件或服务参数的陈述与 TI 标明的参数相比存在差异或虚假成分,则会失去相关 TI 组件或服务的所有明示或暗示授权,且这是不正当的、欺诈性商业行为。TI 对任何此类虚假陈述均不承担任何责任或义务。

客户认可并同意,尽管任何应用相关信息或支持仍可能由 TI 提供,但他们将独立负责满足与其产品及其在应用中使用的 TI 产品相关的所有法律、法规和安全相关要求。客户声明并同意,他们具备制定与实施安全措施所需的全部专业技术和知识,可预见故障的危险后果、监测故障及其后果、降低有可能造成人身伤害的故障的发生机率并采取适当的补救措施。客户将全额赔偿因在此类安全关键应用中使用任何 TI 组件而对 TI 及其代理造成的任何损失。

在某些场合中,为了推进安全相关应用有可能对 TI 组件进行特别的促销。TI 的目标是利用此类组件帮助客户设计和创立其特有的可满足适用的功能安全性标准和要求的终端产品解决方案。尽管如此,此类组件仍然服从这些条款。

TI 组件未获得用于 FDA Class III (或类似的生命攸关医疗设备)的授权许可,除非各方授权官员已经达成了专门管控此类使用的特别协议。

只有那些 TI 特别注明属于军用等级或“增强型塑料”的 TI 组件才是设计或专门用于军事/航空应用或环境的。购买者认可并同意,对并非指定面向军事或航空航天用途的 TI 组件进行军事或航空航天方面的应用,其风险由客户单独承担,并且由客户独立负责满足与此类使用相关的所有法律和法规要求。

TI 已明确指定符合 ISO/TS16949 要求的产品,这些产品主要用于汽车。在任何情况下,因使用非指定产品而无法达到 ISO/TS16949 要求, TI 不承担任何责任。

	产品		应用
数字音频	www.ti.com.cn/audio	通信与电信	www.ti.com.cn/telecom
放大器和线性器件	www.ti.com.cn/amplifiers	计算机及周边	www.ti.com.cn/computer
数据转换器	www.ti.com.cn/dataconverters	消费电子	www.ti.com.cn/consumer-apps
DLP® 产品	www.dlp.com	能源	www.ti.com.cn/energy
DSP - 数字信号处理器	www.ti.com.cn/dsp	工业应用	www.ti.com.cn/industrial
时钟和计时器	www.ti.com.cn/clockandtimers	医疗电子	www.ti.com.cn/medical
接口	www.ti.com.cn/interface	安防应用	www.ti.com.cn/security
逻辑	www.ti.com.cn/logic	汽车电子	www.ti.com.cn/automotive
电源管理	www.ti.com.cn/power	视频和影像	www.ti.com.cn/video
微控制器 (MCU)	www.ti.com.cn/microcontrollers		
RFID 系统	www.ti.com.cn/rfidsys		
OMAP应用处理器	www.ti.com/omap		
无线连通性	www.ti.com.cn/wirelessconnectivity	德州仪器在线技术支持社区	www.deyisupport.com

邮寄地址: 上海市浦东新区世纪大道1568号, 中建大厦32楼邮政编码: 200122
Copyright © 2014, 德州仪器半导体技术(上海)有限公司

PACKAGING INFORMATION

Orderable Device	Status (1)	Package Type	Package Drawing	Pins	Package Qty	Eco Plan (2)	Lead finish/ Ball material (6)	MSL Peak Temp (3)	Op Temp (°C)	Device Marking (4/5)	Samples
TPS8268090SIPR	ACTIVE	uSiP	SIP	9	3000	RoHS & Green	SNAGCU	Level-2-260C-1 YEAR	-40 to 85	YP	Samples
TPS8268090SIPT	ACTIVE	uSiP	SIP	9	250	RoHS & Green	SNAGCU	Level-2-260C-1 YEAR	-40 to 85	YP	Samples
TPS8268105SIPR	ACTIVE	uSiP	SIP	9	3000	RoHS & Green	SNAGCU	Level-2-260C-1 YEAR	-40 to 85	YO	Samples
TPS8268105SIPT	ACTIVE	uSiP	SIP	9	250	RoHS & Green	SNAGCU	Level-2-260C-1 YEAR	-40 to 85	YO	Samples
TPS8268150SIPR	ACTIVE	uSiP	SIP	9	3000	RoHS & Green	SNAGCU	Level-2-260C-1 YEAR	-40 to 85	YR	Samples
TPS8268150SIPT	ACTIVE	uSiP	SIP	9	250	RoHS & Green	SNAGCU	Level-2-260C-1 YEAR	-40 to 85	YR	Samples

(1) The marketing status values are defined as follows:

ACTIVE: Product device recommended for new designs.

LIFEBUY: TI has announced that the device will be discontinued, and a lifetime-buy period is in effect.

NRND: Not recommended for new designs. Device is in production to support existing customers, but TI does not recommend using this part in a new design.

PREVIEW: Device has been announced but is not in production. Samples may or may not be available.

OBSOLETE: TI has discontinued the production of the device.

(2) **RoHS:** TI defines "RoHS" to mean semiconductor products that are compliant with the current EU RoHS requirements for all 10 RoHS substances, including the requirement that RoHS substance do not exceed 0.1% by weight in homogeneous materials. Where designed to be soldered at high temperatures, "RoHS" products are suitable for use in specified lead-free processes. TI may reference these types of products as "Pb-Free".

RoHS Exempt: TI defines "RoHS Exempt" to mean products that contain lead but are compliant with EU RoHS pursuant to a specific EU RoHS exemption.

Green: TI defines "Green" to mean the content of Chlorine (Cl) and Bromine (Br) based flame retardants meet JS709B low halogen requirements of <=1000ppm threshold. Antimony trioxide based flame retardants must also meet the <=1000ppm threshold requirement.

(3) MSL, Peak Temp. - The Moisture Sensitivity Level rating according to the JEDEC industry standard classifications, and peak solder temperature.

(4) There may be additional marking, which relates to the logo, the lot trace code information, or the environmental category on the device.

(5) Multiple Device Markings will be inside parentheses. Only one Device Marking contained in parentheses and separated by a "~" will appear on a device. If a line is indented then it is a continuation of the previous line and the two combined represent the entire Device Marking for that device.

(6) Lead finish/Ball material - Orderable Devices may have multiple material finish options. Finish options are separated by a vertical ruled line. Lead finish/Ball material values may wrap to two lines if the finish value exceeds the maximum column width.

Important Information and Disclaimer: The information provided on this page represents TI's knowledge and belief as of the date that it is provided. TI bases its knowledge and belief on information provided by third parties, and makes no representation or warranty as to the accuracy of such information. Efforts are underway to better integrate information from third parties. TI has taken and continues to take reasonable steps to provide representative and accurate information but may not have conducted destructive testing or chemical analysis on incoming materials and chemicals. TI and TI suppliers consider certain information to be proprietary, and thus CAS numbers and other limited information may not be available for release.

In no event shall TI's liability arising out of such information exceed the total purchase price of the TI part(s) at issue in this document sold by TI to Customer on an annual basis.

TAPE AND REEL INFORMATION

QUADRANT ASSIGNMENTS FOR PIN 1 ORIENTATION IN TAPE

*All dimensions are nominal

Device	Package Type	Package Drawing	Pins	SPQ	Reel Diameter (mm)	Reel Width W1 (mm)	A0 (mm)	B0 (mm)	K0 (mm)	P1 (mm)	W (mm)	Pin1 Quadrant
TPS8268090SIPR	uSiP	SIP	9	3000	178.0	9.0	2.45	3.05	1.1	4.0	8.0	Q2
TPS8268090SIPT	uSiP	SIP	9	250	178.0	9.0	2.45	3.05	1.1	4.0	8.0	Q2
TPS8268105SIPR	uSiP	SIP	9	3000	178.0	9.0	2.45	3.05	1.1	4.0	8.0	Q2
TPS8268105SIPT	uSiP	SIP	9	250	178.0	9.0	2.45	3.05	1.1	4.0	8.0	Q2
TPS8268150SIPR	uSiP	SIP	9	3000	178.0	9.0	2.45	3.05	1.1	4.0	8.0	Q2
TPS8268150SIPT	uSiP	SIP	9	250	178.0	9.0	2.45	3.05	1.1	4.0	8.0	Q2

TAPE AND REEL BOX DIMENSIONS

*All dimensions are nominal

Device	Package Type	Package Drawing	Pins	SPQ	Length (mm)	Width (mm)	Height (mm)
TPS8268090SIPR	uSiP	SIP	9	3000	223.0	194.0	35.0
TPS8268090SIPT	uSiP	SIP	9	250	223.0	194.0	35.0
TPS8268105SIPR	uSiP	SIP	9	3000	223.0	194.0	35.0
TPS8268105SIPT	uSiP	SIP	9	250	223.0	194.0	35.0
TPS8268150SIPR	uSiP	SIP	9	3000	223.0	194.0	35.0
TPS8268150SIPT	uSiP	SIP	9	250	223.0	194.0	35.0

重要声明和免责声明

TI 提供技术和可靠性数据（包括数据表）、设计资源（包括参考设计）、应用或其他设计建议、网络工具、安全信息和其他资源，不保证没有瑕疵且不做任何明示或暗示的担保，包括但不限于对适销性、某特定用途方面的适用性或不侵犯任何第三方知识产权的暗示担保。

这些资源可供使用 TI 产品进行设计的熟练开发人员使用。您将自行承担以下全部责任：(1) 针对您的应用选择合适的 TI 产品，(2) 设计、验证并测试您的应用，(3) 确保您的应用满足相应标准以及任何其他安全、安保或其他要求。这些资源如有变更，恕不另行通知。TI 授权您仅可将这些资源用于研发本资源所述的 TI 产品的应用。严禁对这些资源进行其他复制或展示。您无权使用任何其他 TI 知识产权或任何第三方知识产权。您应全额赔偿因在这些资源的使用中对 TI 及其代表造成的任何索赔、损害、成本、损失和债务，TI 对此概不负责。

TI 提供的产品受 TI 的销售条款 (<https://www.ti.com.cn/zh-cn/legal/termsofsale.html>) 或 [ti.com.cn](https://www.ti.com.cn) 上其他适用条款/TI 产品随附的其他适用条款的约束。TI 提供这些资源并不会扩展或以其他方式更改 TI 针对 TI 产品发布的适用的担保或担保免责声明。

邮寄地址：上海市浦东新区世纪大道 1568 号中建大厦 32 楼，邮政编码：200122
Copyright © 2021 德州仪器半导体技术（上海）有限公司