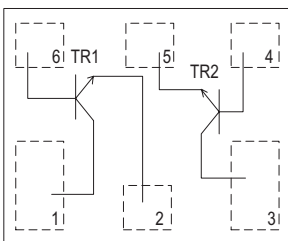
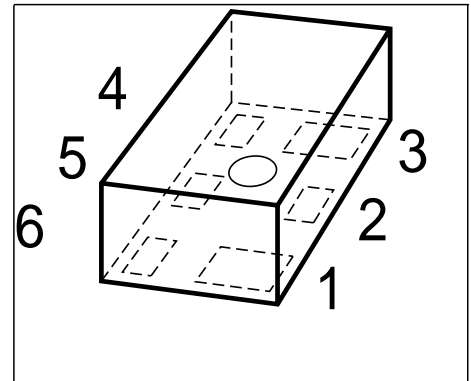

NPN Silicon RF TWIN Transistor

Preliminary data

- Low voltage/ low current applications
- Ideal for VCO modules and low noise amplifiers
- Low noise figure: TR1: 1.1dB at 1.8 GHz
TR2: 1.0 dB at 1.8 GHz
- World's smallest SMD 6-pin leadless package
- Built in 2 transistors (TR1: die as BFR460L3,
TR2: die as BFR360L3)

ESD: Electrostatic discharge sensitive device, observe handling precaution!

Type	Marking	Pin Configuration						Package
BFS466L6	AC	1=C1	2=E1	3=C2	4=B2	5=E2	6=B1	TSLP-6-1

Maximum Ratings

Parameter	Symbol	Value	Unit
Collector-emitter voltage	V_{CEO}		V
TR1		4.5	
TR2		6	
Collector-emitter voltage	V_{CES}		
TR1		15	
TR2		15	
Collector-base voltage	V_{CBO}		
TR1		15	
TR2		15	
Emitter-base voltage	V_{EBO}		
TR1		1.5	
TR2		2	
Collector current	I_C		mA
TR1		50	
TR2		35	

Maximum Ratings

Parameter	Symbol	Value	Unit
Base current	I_B		mA
TR1		5	
TR2		4	
Total power dissipation ¹⁾	P_{tot}		mW
TR1, $T_S \leq 104^\circ\text{C}$		200	
TR2, $T_S \leq 102^\circ\text{C}$		210	
Junction temperature	T_j		$^\circ\text{C}$
TR1		150	
TR2		150	
Ambient temperature	T_A		
TR1		-65 ... 150	
TR2		-65 ... 150	
Storage temperature	T_{stg}		
TR1		-65 ... 150	
TR2		-65 ... 150	

Thermal Resistance

Parameter	Symbol	Value	Unit
Junction - soldering point ²⁾	R_{thJS}		K/W
TR1		≤ 230	
TR2		≤ 230	

¹⁾ T_S is measured on the collector lead at the soldering point to the pcb

²⁾For calculation of R_{thJA} please refer to Application Note Thermal Resistance

Electrical Characteristics at $T_A = 25^\circ\text{C}$, unless otherwise specified

Parameter	Symbol	Values			Unit
		min.	typ.	max.	
DC Characteristics					
Collector-emitter breakdown voltage TR1, $I_C = 1\text{ mA}$, $I_B = 0$ TR2, $I_C = 1\text{ mA}$, $I_B = 0$	$V_{(BR)CEO}$	4.5 6	5 9	- -	V
Collector-emitter cutoff current TR1, $V_{CE} = 15\text{ V}$, $V_{BE} = 0$ TR2, $V_{CE} = 15\text{ V}$, $V_{BE} = 0$	I_{CES}	- -	- -	10 10	μA
Collector-base cutoff current TR1, $V_{CB} = 5\text{ V}$, $I_E = 0$ TR2, $V_{CB} = 5\text{ V}$, $I_E = 0$	I_{CBO}	- -	- -	100 100	nA
Emitter-base cutoff current TR1, $V_{EB} = 0,5\text{ V}$, $I_C = 0$ TR2, $V_{EB} = 1\text{ V}$, $I_C = 0$	I_{EBO}	- -	- -	1 1	μA
DC current gain TR1, $I_C = 20\text{ mA}$, $V_{CE} = 3\text{ V}$ TR2, $I_C = 20\text{ mA}$, $V_{CE} = 3\text{ V}$	h_{FE}	- 90	130 130	- 160	-

Electrical Characteristics at $T_A = 25^\circ\text{C}$, unless otherwise specified

Parameter	Symbol	Values			Unit
		min.	typ.	max.	
AC Characteristics (verified by random sampling)					
Transition frequency TR1, $I_C = 30\text{ mA}$, $V_{CE} = 3\text{ V}$, $f = 1\text{ GHz}$ TR2, $I_C = 15\text{ mA}$, $V_{CE} = 3\text{ V}$, $f = 1\text{ GHz}$	f_T	16 11	22 14	- -	GHz
Collector-base capacitance TR1, $V_{CB} = 3\text{ V}$, $f = 1\text{ MHz}$, emitter grounded TR2, $V_{CB} = 5\text{ V}$, $f = 1\text{ MHz}$, emitter grounded	C_{cb}	- -	0.33 0.3	0.5 0.45	pF
Collector emitter capacitance TR1, $V_{CE} = 3\text{ V}$, $f = 1\text{ MHz}$, base grounded TR1, $V_{CE} = 3\text{ V}$, $f = 1\text{ MHz}$, base grounded	C_{ce}	- -	0.17 0.17	- -	
Emitter-base capacitance TR1, $V_{EB} = 0,5\text{ V}$, $f = 1\text{ MHz}$, collector grounded TR2, $V_{EB} = 0,5\text{ V}$, $f = 1\text{ MHz}$, collector grounded	C_{eb}	- -	0.57 0.48	- -	

Electrical Characteristics at TA = 25°C, unless otherwise specified

Parameter	Symbol	Values			Unit
		min.	typ.	max.	
AC Characteristics (verified by random sampling)					
Noise figure	F				dB
TR1, $I_C=5\text{mA}$, $V_{CE} = 3\text{ V}$, $f = 1.8\text{ GHz}$, $Z_S = Z_{\text{Sopt}}$		-	1.1	-	
TR1, $I_C=5\text{mA}$, $V_{CE} = 3\text{ V}$, $f = 3\text{ GHz}$, $Z_S = Z_{\text{Sopt}}$		-	1.4	-	
TR2, $I_C=3\text{mA}$, $V_{CE} = 3\text{ V}$, $f = 1.8\text{ GHz}$, $Z_S = Z_{\text{Sopt}}$		-	1	-	
TR2, $I_C=3\text{mA}$, $V_{CE} = 3\text{ V}$, $f = 3\text{ GHz}$, $Z_S = Z_{\text{Sopt}}$		-	1.4	-	
Power gain, maximum available ¹⁾	G_{ma}				
TR1, $I_C = 20\text{ mA}$, $V_{CE} = 3\text{ V}$, $Z_S=Z_{\text{Sopt}}$, $Z_L=Z_{\text{Lopt}}$, $f = 1.8\text{ GHz}$		-	14.5	-	
TR1, $I_C = 20\text{ mA}$, $V_{CE} = 3\text{ V}$, $Z_S=Z_{\text{Sopt}}$, $Z_L=Z_{\text{Lopt}}$, $f = 3\text{ GHz}$		-	10	-	
TR2, $I_C = 15\text{ mA}$, $V_{CE} = 3\text{ V}$, $Z_S=Z_{\text{Sopt}}$, $Z_L=Z_{\text{Lopt}}$, $f = 1.8\text{ GHz}$		-	14.5	-	
TR2, $I_C = 15\text{ mA}$, $V_{CE} = 3\text{ V}$, $Z_S=Z_{\text{Sopt}}$, $Z_L=Z_{\text{Lopt}}$, $f = 3\text{ GHz}$		-	10	-	
Transducer gain	$ S_{21e} ^2$				
TR1, $I_C = 20\text{ mA}$, $V_{CE} = 3\text{ V}$, $Z_S = Z_L = 50\Omega$, $f = 1.8\text{GHz}$		-	12.5	-	
TR1, $I_C = 20\text{ mA}$, $V_{CE} = 3\text{ V}$, $Z_S = Z_L = 50\Omega$, $f = 3\text{GHz}$		-	9	-	
TR2, $I_C = 15\text{ mA}$, $V_{CE} = 3\text{ V}$, $Z_S = Z_L = 50\Omega$, $f = 1.8\text{GHz}$		-	12.5	-	
TR2, $I_C = 15\text{ mA}$, $V_{CE} = 3\text{ V}$, $Z_S = Z_L = 50\Omega$, $f = 3\text{GHz}$		-	8.5	-	
Third order intercept point at output ²⁾	IP_3				dBm
TR1, $V_{CE}=3\text{V}$, $I_C=20\text{mA}$, $Z_S=Z_L=50\Omega$, $f=1.8\text{GHz}$		-	28	-	
TR2, $V_{CE}=3\text{V}$, $I_C=15\text{mA}$, $Z_S=Z_L=50\Omega$, $f=1.8\text{GHz}$		-	24.5	-	
1dB Compression point, at output	$P_{-1\text{dB}}$				
TR1, $I_C=20\text{mA}$, $V_{CE}=3\text{V}$, $Z_S=Z_L=50\Omega$, $f=1.8\text{GHz}$		-	12	-	
TR1, $I_C=15\text{mA}$, $V_{CE}=3\text{V}$, $Z_S=Z_L=50\Omega$, $f=1.8\text{GHz}$		-	9	-	

$$^1G_{\text{ma}} = |S_{21e} / S_{12e}| (k - (k^2 - 1)^{1/2})$$

²IP3 value depends on termination of all intermodulation frequency components.

Termination used for this measurement is 50Ω from 0.1 MHz to 6 GHz

**Published by Infineon Technologies AG,
St.-Martin-Strasse 53,
81669 München**

**© Infineon Technologies AG 2004.
All Rights Reserved.**

Attention please!

The information herein is given to describe certain components and shall not be considered as a guarantee of characteristics.

Terms of delivery and rights to technical change reserved.

We hereby disclaim any and all warranties, including but not limited to warranties of non-infringement, regarding circuits, descriptions and charts stated herein.

Information

For further information on technology, delivery terms and conditions and prices please contact your nearest Infineon Technologies Office (www.infineon.com).

Warnings

Due to technical requirements components may contain dangerous substances. For information on the types in question please contact your nearest Infineon Technologies Office.

Infineon Technologies Components may only be used in life-support devices or systems with the express written approval of Infineon Technologies, if a failure of such components can reasonably be expected to cause the failure of that life-support device or system, or to affect the safety or effectiveness of that device or system. Life support devices or systems are intended to be implanted in the human body, or to support and/or maintain and sustain and/or protect human life. If they fail, it is reasonable to assume that the health of the user or other persons may be endangered.

This datasheet has been download from:

www.datasheetcatalog.com

Datasheets for electronics components.