

- **Applications**

Inverter, Interface, Driver

- **Features**

- 1) Built-in bias resistors enable the configuration of an inverter circuit without connecting external input resistors (see equivalent circuit).
- 2) The bias resistors consist of thin-film resistors with complete isolation to allow positive biasing of the input. They also have the advantage of almost completely eliminating parasitic effects.
- 3) Only the on/off conditions need to be set for operation, making the device design easy.

- We declare that the material of product compliance with RoHS requirements.

- **Absolute maximum ratings** (Ta=25°C)

Parameter	Symbol	Limits	Unit
Collector-base voltage	V <sub>CB0</sub>	-50	V
Collector-emitter voltage	V <sub>CEO</sub>	-50	V
Emitter-base voltage	V <sub>EBO</sub>	-5	V
Collector current	I <sub>c</sub>	-100	mA
Collector Power dissipation	P <sub>C</sub>	200	mW
Junction temperature	T <sub>j</sub>	150	°C
Storage temperature	T <sub>stg</sub>	-55 to +150	°C

### DEVICE MARKING AND RESISTOR VALUES

Device	Marking	R1 (K)	R2 (K)	Shipping
DTA115TET1G	O8	100	-	3000/Tape & Reel
DTA115TET1G	O8	100	-	10000/Tape & Reel

- **Electrical characteristics** (Ta=25°C)

Parameter	Symbol	Min.	Typ.	Max.	Unit	Conditions
Collector-base breakdown voltage	BV <sub>CB0</sub>	-50	-	-	V	I <sub>c</sub> = -50μA
Collector-emitter breakdown voltage	BV <sub>CEO</sub>	-50	-	-	V	I <sub>c</sub> = -1mA
Emitter-base breakdown voltage	BV <sub>EBO</sub>	-5	-	-	V	I <sub>E</sub> = -50μA
Collector cutoff current	I <sub>cBO</sub>	-	-	-0.5	μA	V <sub>CB</sub> = -50V
Emitter cutoff current	I <sub>EBO</sub>	-	-	-0.5	μA	V <sub>EB</sub> = -4V
Collector-emitter saturation voltage	V <sub>CE(sat)</sub>	-	-	-0.3	V	I <sub>c</sub> /I <sub>B</sub> = -1mA/-0.1mA
DC current transfer ratio	h <sub>FE</sub>	100	250	600	-	I <sub>c</sub> = -1mA , V <sub>CE</sub> = -5V
Input resistance	R <sub>1</sub>	70	100	130	kΩ	-
Transition frequency	f <sub>T</sub> *	-	250	-	MHz	V <sub>CE</sub> = -10V , I <sub>E</sub> =5mA , f=100MHz

\*Characteristics of built-in transistor

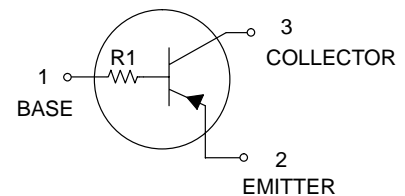
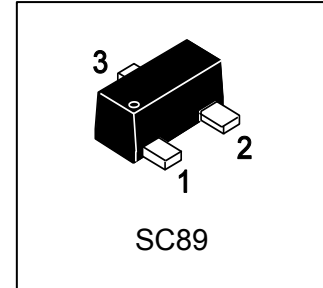

● **Electrical characteristic curves**

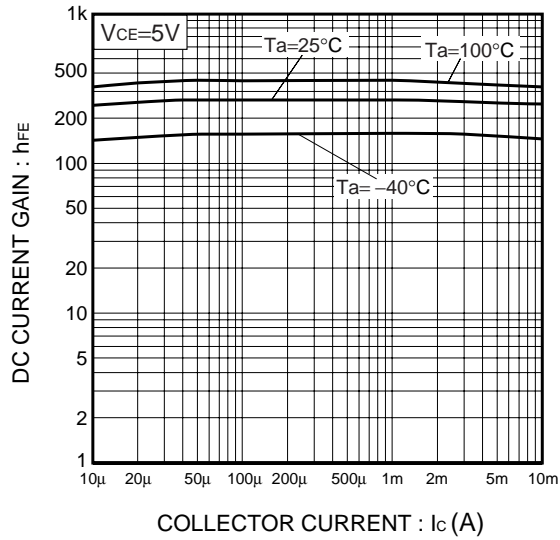

Fig.1 DC current gain vs. Collector current

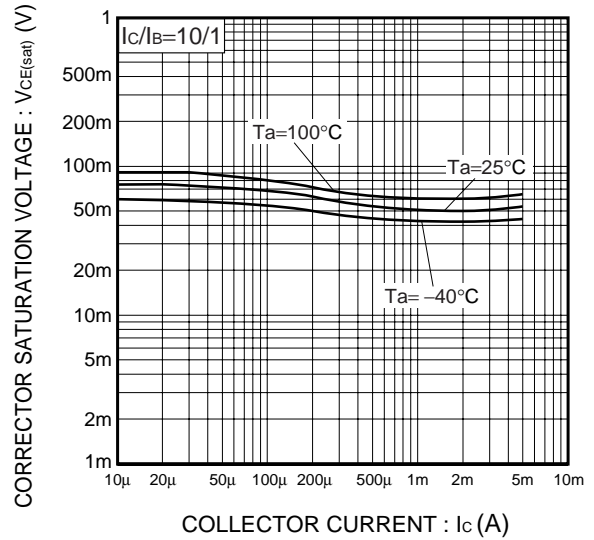
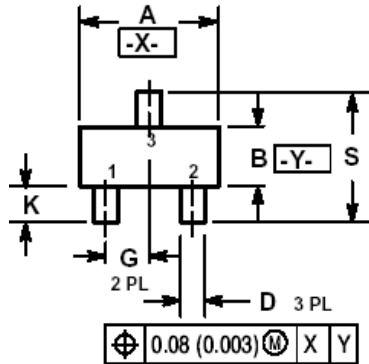

Fig.2 Collector-Emitter saturation voltage vs. Collector current

**SC-89**



**NOTES:**

1. DIMENSIONING AND TOLERANCING PER ANSI Y14.5M, 1982.
2. CONTROLLING DIMENSION: MILLIMETERS
3. MAXIMUM LEAD THICKNESS INCLUDES LEAD FINISH THICKNESS. MINIMUM LEAD THICKNESS IS THE MINIMUM THICKNESS OF BASE MATERIAL.
4. 463C-01 OBSOLETE, NEW STANDARD 463C-02.

DIM	MILLIMETERS			INCHES		
	MIN	NOM	MAX	MIN	NOM	MAX
A	1.50	1.60	1.70	0.059	0.063	0.067
B	0.75	0.85	0.95	0.030	0.034	0.040
C	0.60	0.70	0.80	0.024	0.028	0.031
D	0.23	0.28	0.33	0.009	0.011	0.013
G	0.50 BSC			0.020 BSC		
H	0.53 REF			0.021 REF		
J	0.10	0.15	0.20	0.004	0.006	0.008
K	0.30	0.40	0.50	0.012	0.016	0.020
L	1.10 REF			0.043 REF		
M	---	---	10 °	---	---	10 °
N	---	---	10 °	---	---	10 °
S	1.50	1.60	1.70	0.059	0.063	0.067

