

XE1218 – Single Chip Receiver

FM 130 - 230 MHz

Low-Power VHF Receiver

Features

- Ultra low voltage operation : down to 1 Volt
- Ultra low-power consumption : 2 mA
- Highly integrated single chip audio receiver : antenna in, loudspeaker out
- High sensitivity : -107 dBm
- AFC range +/- 10 kHz
- Mute function
- 6 kHz audio bandwidth
- 45 dB Audio SNR
- Integrated audio amplifier

Applications

- Toys
- Local/Wide area voice paging
- FM broadcasting miniature receiver
- Wireless phone headset

Ordering Information

Part	Temperature range	Pin-package
XE1218	-10 to 55° C	Naked die form

General Description

The XE1218 is a single chip ultra low-power VHF FM receiver. The circuit includes the RF receiver section, the demodulator and the audio amplifier that is directly connected to an external earpiece. It uses analog narrow-band FM modulation. The XE1218 is based on a low-IF architecture, with on-chip channel filter and a delay line type demodulator. The LO is generated by a crystal oscillator.

Quick Reference Data

- Supply voltage 1 to 1.6 V
- Current consumption 2 mA
- Modulation Narrow-band FM
- Sensitivity -107 dBm
- Carrier frequency 130 – 230 MHz

XE1218

Ultra Low Power VHF Receiver

Detailed Pin Description

PIN	NAME	DESCRIPTION	TYPE
1	LOP	LO tank connexion	A
2	LON	LO tank connexion	A
3	XTALP	Crystal pin	A
4	XTALN	Crystal pin	A
5	RFTANK	LNA tank connexion	A
6	RFVCC	Positive supply voltage of receiver front-end	P
7	RFIN	RF input	A
8	RFGND	Antenna ground node	P
9	MUTE	Mute digital output	D
10	IFTEST	Testpad IF amplifier	A
11	VM	Buffer capacitance	A
12	OUTH	High impedance audio output (10 kOhms)	A
13	OUTL	Low impedance audio output (<250 Ohms)	A
14	VOL	Volume control	A
15	DIR	High pass output filter ON/OFF	
16	BW4K	Audio output filter 4kHz ON/OFF	
17	PM	Low-Pass output filter (PM) ON/OFF	
18	VSS	Analog and digital negative supply voltage	P
19	STAB	Decoupling pin for audio stage	A
20	VREG	Input of regulated voltage (for Standby mode)	A
21	VDD	Analog and digital positive supply voltage	P
22	EAR	Audio output for headphone	A

Absolute Ratings

- supply voltage 1 V to 2 V
- operating temperature range -10 to 40 C
- storage temperature -55°C to 150°C

XE1218

Ultra Low Power VHF Receiver

Electrical Characteristics

T_{amb} = 25° C; VDD = 1.25 V, Temp=25 °C, f_{RFIN}=160 MHz, unless otherwise specified.

Symbol	Parameters	Conditions	Min	Typ	Max	Unit
VDD	Power supply		1	1.25	1.6	
IDD_REC	Supply current	Receiver ON	-		2	mA
IDD_STDB	Supply current in standby		-	-	100	μA
RFIN	Input carrier frequency range		130	-	230	MHz
FDEV	Frequency deviation		-	-	8	kHz
RFS	RF input sensitivity	f _{mod} = 1 kHz, f _{dev} = 3 kHz, SINAD = 10 dB,	-92	-105		dBm
ACR	Adjacent channel rejection	f _{unw} = f _{RFIN} + 100 kHz, f _{mod} = 1 kHz, f _{dev} = 3 kHz, Pin=RFS+10 dB, SINAD=10 dB	-	50	-	dB
AOB	Audio -3 dB bandwidth on output EAR	f _{dev} = 3 kHz	0.1	-	6	kHz
AOD	Audio distortion on output EAR	f _{mod} = 1 kHz, f _{dev} = 5 kHz, Rvol = 100 kOhms, Pin = -60 dBm, BW = 20 kHz	-	2	8	%
ASN	Audio SNR on output EAR	f _{mod} = 1 kHz, f _{dev} = 3 kHz, Rvol = 100 kOhms, Pin = -60 dBm, BW = 6 kHz	42	45	-	dB
DCEAR	DC voltage on output EAR	Vdd = 1.3 V	200	-	300	mV
LOD	LO shift	Temperature drift and aging of crystal not taken into account	-	-	± 15	ppm

XE1218

Ultra Low Power VHF Receiver

Block diagram and typical application

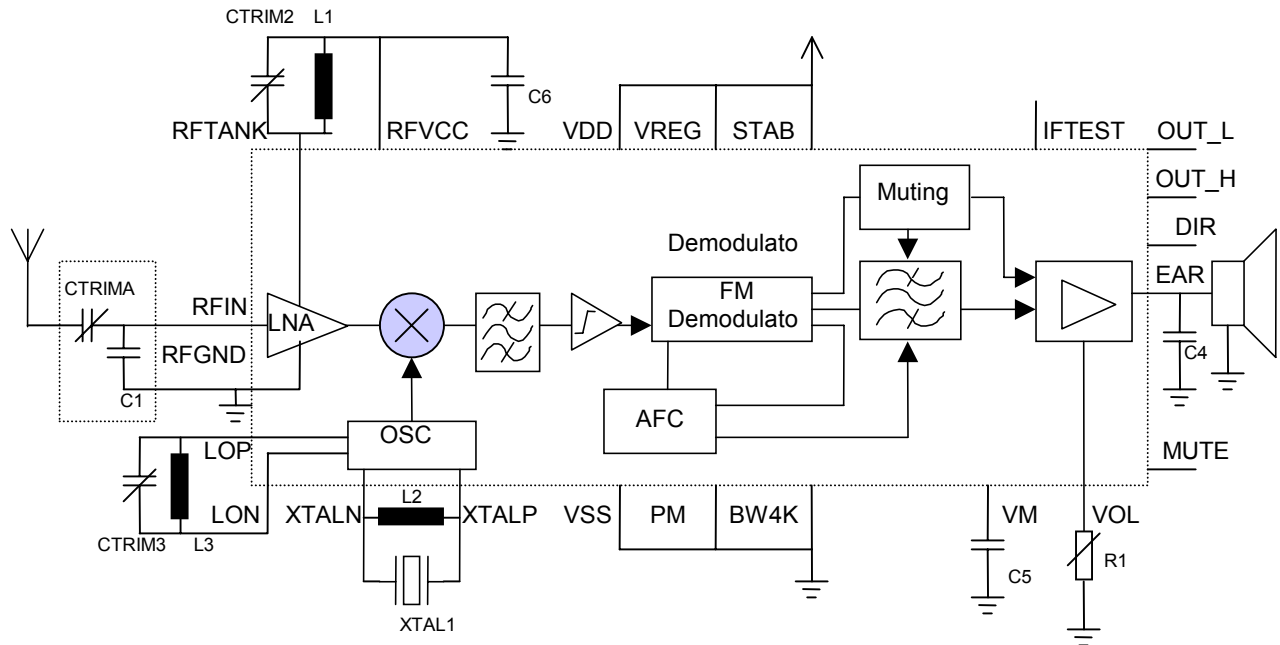

Components list for F=171 MHz

Component	Type	Value
XTAL1	Overtone crystal, serial resonance	Ex. F=171.525 Cs=0.17 fF, Rs<120 Ohms Q>40000, Cp = 3.2 pF
L1		0.15 uH
L2		0.18 uH
L3		0.18 uH
C1		10 pF
CTRIM2		2.5 pF
CTRIM3		3.2 pF
C4		1 nF
C5		10 nF
CTRIMA		6.4 pF
R1		0-100K ohm

XE1218

Ultra Low Power VHF Receiver

LNA and antenna matching network

See application diagram above

Note: For test purpose, the antenna and its matching network is replaced by the following set-up

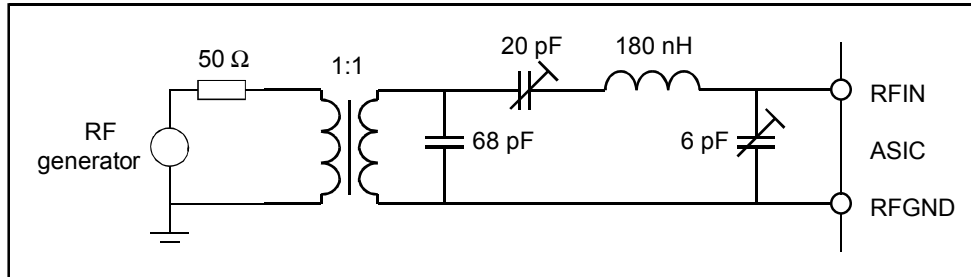

RF and LO tank

See application diagram above

Crystal

The typical characteristics of a crystal used for the LO generation are the following:

- Supplier: Telequarz,
- Type: HSLX5132 or HSLX5134 (7th overtone),
- Frequency: 160.275 MHz,
- Motional capacitance $C_s = 0.2 \text{ fF} \pm 0.15 \text{ fF}$,
- Calibration tolerance at 25 °C: $\pm 10 \text{ ppm}$,
- Stability over temperature range: $\pm 5 \text{ ppm}$,
- Aging in the first year: $\pm 3 \text{ ppm}$.

XE1218

Ultra Low Power VHF Receiver

Earphone

The typical characteristics of the earphone connected to the output EAR are the following:

- Supplier: Knowles,
- Type: EH 7314.

The model of this earphone is given in the next figure.

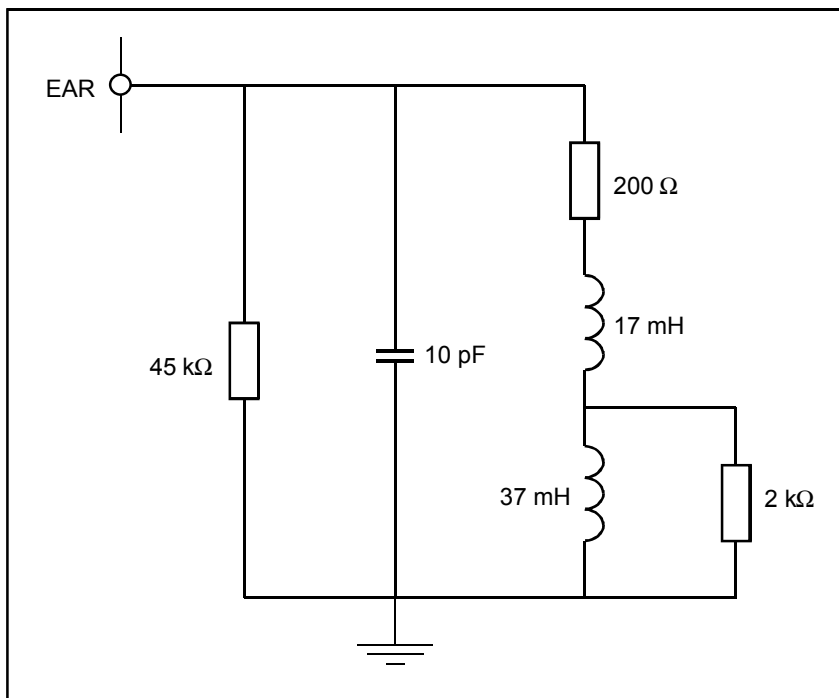

XE1218

Ultra Low Power VHF Receiver

Overall functional description

The circuit is an FM receiver. It is composed of the following main functional blocks:

- the receiver chain including the audio output stage
- the local oscillator (LO),
- the control and service blocks,

The receiver is implemented with the following blocks:

- a low-noise amplifier (LNA),
- a mixer as a down-converter, whose function is to transfer the signal from VHF band to an intermediate frequency (IF) of 25 kHz,
- an offset cancellation block, whose function is to attenuate the DC and quasi-DC signals,
- an IF filter chain, whose function is to amplify and filter the IF signal,
- a limiter, providing the demodulator with fully digital signals,
- a digital delay line FM demodulator, which converts the signal from the limiter into a pulse width modulated signal at twice the IF frequency; this block also generates AFC and MUTE signals; the AFC signal is used inside the demodulator to have its clock frequency track the IF frequency,
- an audio stage, whose function is to filter the input PWM signal and to provide volume control and output buffering; the MUTE signal generated by the demodulator is used by this block to switch on/off the output buffer driving the EAR output.

LNA : NF is less than 6 dB, for an antenna impedance in the 1 to 2 kOhm range. Out of the 6 dB, 3dB are due to the noise at the image frequency, which is not rejected. The sensitivity is -107 dBm (SINAD=10 dB, fdev = 3kHz)

Mixers : This is implemented as a Gilbert cell. CAUTION : DUE TO INITIAL DESIGN CONSTRAINTS, CHOICE OF ARCHITECTURE, NO IMAGE REJECTION FEATURES IS PROVIDED ON CHIP. FOR EXAMPLE IF $F_{lo}=F-25$ kHz, THEN THE IMAGE FREQUENCY AT $F - 50$ kHz IS NOT ATTENUATED. IN CASE OF MULTICHANNEL OPERATION, THE CARRIER SHOULD BE SPACED BY 100 OR 200 KHZ

Offset cancelation : This attenuate DC signal before IF chain

IF amplifier chain : This block provides amplification and low pass filtering (>65 dB attenuation 100 kHz away from the 25 kHz IF frequency).

Limiter / Demodulator which converts the signal from the IF amplifier into a pulse width modulated signal at twice the IF frequency; this block also generates AFC and MUTE signals; the AFC signal is used inside the demodulator to have its clock frequency track the IF frequency. The MUTE circuit in the FM demodulator detects when the received signal is too weak. When that is the case, the audio outputs will be muted so that the user doesn't hear all the noise.

The local oscillator provides the mixer of the receiver with the proper LO. It is implemented with a quartz oscillator working on an overtone of the quartz.

The service blocks provide the necessary bias currents and voltages. This includes a voltage doubler circuit.

XE1218

Ultra Low Power VHF Receiver

I/O Pad Location & Assembly

XE1218 is not packaged, but be delivered as such for chip-on-board mounting.

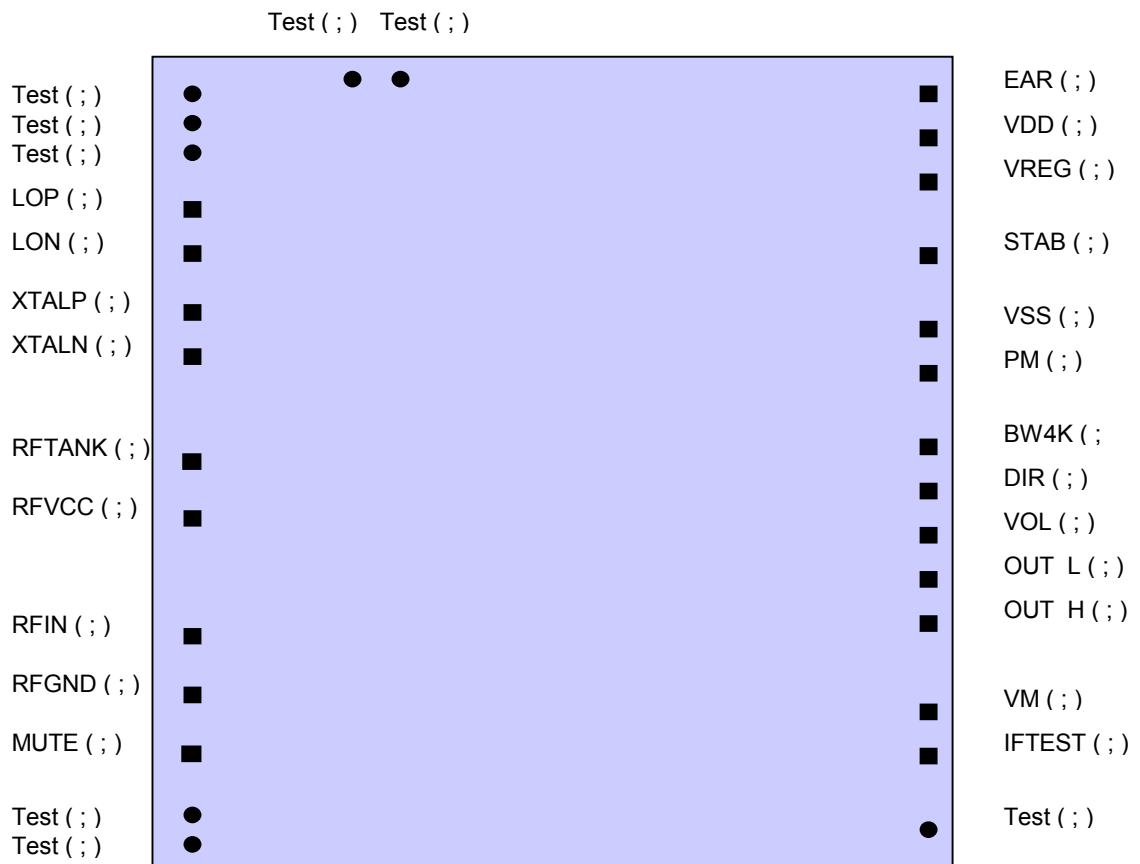

©XEMICS 2001

All rights reserved. Reproduction whole or in part is prohibited without the prior written consent of the copyright owner. The information presented in this document does not form part of any quotation or contract, is believed to be accurate and reliable and may be changed without notice. No liability will be accepted by the publisher for any consequence of its use. Publication thereof does not convey nor imply any license under patent- or other industrial or intellectual property rights.